

Software version : V2.12.3
Document version : V2.12.3
Original instructions(English)

User manual (V2.12.3)



M0609 | M0617 | M1013 | M1509 | H2017 |
H2515

DOOSAN

© 2025 Doosan Robotics Inc.

Table of Contents

1	PART 1. Safety Manual.....	9
1.1	Manual Indication Conventions.....	9
1.2	Safety Symbols.....	9
1.3	General Instructions	10
1.4	Precautions for Use.....	11
1.5	Product Usage	13
1.6	Risk Assessment	13
1.7	Potential Risks	15
1.8	Robot Mode and State	15
1.8.1	Manual Mode.....	15
1.8.2	Automatic Mode	15
1.8.3	Other Mode	16
1.8.4	Status and Flange LED Color for Each Mode.....	16
1.9	Product Warranty and Responsibility	20
1.9.1	Scope of Warranty	20
1.9.2	Restrictions and Exceptions of Warranty	20
1.9.3	Transfer.....	21
1.9.4	Contact.....	21
1.10	Safety Function	21
1.10.1	Safety-rated Stop Subfunction	22
1.10.2	Safety-rated Stop Function	24
1.10.3	Safety-rated Monitoring Function	25
1.10.4	Safety-rated I/O	28
1.11	Safety Function Settings	29
1.11.1	Robot Limits	31
1.11.2	Safety I/O.....	33
1.11.3	Safety Stop Modes	38
1.11.4	Nudge.....	39
1.11.5	Space Limit	40
1.11.6	Zone	40

1.12	Other Safety Measures	41
1.13	Validity and Responsibility	41
1.14	Disclaimer	42
1.15	Declaration and Certification	43
1.15.1	Europe Declaration of Incorporation (Original)	43
1.15.2	Europe Machinery Directive Attestation of Conformity	44
1.15.3	Europe EMC Directive Attestation of Conformity	46
1.15.4	U.S. NRTL Certification (U.S., CANADA)	47
1.15.5	Functional Safety Certification	49
1.15.6	Voluntary Safety Confirmation Declaration (KCs)	51
1.16	Stop Distance and Stop Time	58
1.16.1	Measurement Methods and Conditions	58
1.16.2	M1013 Stop Category	61
1.16.3	M0609 Stop Category	64
1.16.4	M0617 Stop Category	68
1.16.5	M1509 Stop Category	72
1.16.6	H2017 Stop Category	76
1.16.7	H2515 Stop Category	80
1.17	Upper/Lower Threshold Range and Default Value of Safety Parameters .	84
1.17.1	M1013.....	84
1.17.2	M0609.....	85
1.17.3	M0617.....	86
1.17.4	M1509.....	87
1.17.5	H2017	88
1.17.6	H2515	89
2	PART 2. Starting Up the Robot	91
2.1	Journey Map	91
2.1.1	Step 1. Robot Installation.....	91
2.1.2	Step 2. Tool Installation and I/O Testing	92
2.1.3	Step 3. Robot Operation and Setting	92
2.1.4	Step 4. Create Task Program	93
2.2	Step 1. Robot Installation	94
2.2.1	Remove packing	94

2.2.2	Connect cable to the controller.....	95
2.2.3	Secure the robot base	96
2.2.4	Connect controller to robot	96
2.2.5	Connect power to controller.....	97
2.2.6	Position controller.....	98
2.2.7	Power-up controller	98
2.2.8	Disengage emergency stop button	99
2.2.9	Disengage packaging pose	100
2.2.10	Servo Off	104
2.3	Step 2. Tool Installation and I/O Testing	104
2.3.1	Installing the tool	104
2.3.2	Turn system power off	105
2.3.3	Connect wires	106
2.3.4	Turn system power on	107
2.3.5	Test controller and flange I/O	107
2.4	Step 3. Robot Operation and Setting	108
2.4.1	Learn how to engage/disengage Safety Stop.....	109
2.4.2	Manual Operation - Learn how to perform safety recovery/powerless motion	110
2.4.3	Manual Operation - Learn how to use jog	110
2.4.4	Manual Operation - Learn how to perform direct teaching	112
2.4.5	Disengage the Password Lock.....	114
2.4.6	Robot Setting - Set robot limits.....	114
2.4.7	Workcell Item - Add robot installation pose (Mount)	115
2.4.8	Workcell Item - Add Tool Weight	116
2.4.9	Workcell Item - Add Tool Shape.....	116
2.4.10	Workcell Item - Add End Effector	117
2.4.11	Workcell Item - Add Space Limit.....	118
2.4.12	Robot Setting - Set World Coordinates.....	119
2.4.13	Learn about Workcell Manager and Workcell Item	119
2.5	Step 4. Create Task Program.....	120
2.5.1	Start programming.....	121
2.5.2	Understand compliance/force control	122
2.5.3	Utilize Sub/Call Sub	128
2.5.4	Try Compliance command samples	131
2.5.5	Understand robot motion.....	135

2.5.6	Try the sample MoveJ/MoveL commands.....	139
2.5.7	Understand robot motion properties	144
2.5.8	Skill - Try Pick & Place samples	148
2.5.9	Utilize Step Run.....	152
2.5.10	Try force command samples.....	154
2.5.11	Register and manage variables	157
2.5.12	Utilize debugging	161
2.5.13	Function of Operator Intervention	162
3	PART 3. Installation Manual	166
3.1	Product Introduction	166
3.1.1	Component Check	166
3.1.2	Names and functions of each part	167
3.1.3	System Configuration	170
3.1.4	Product Specifications, General.....	172
3.1.5	Robot Specifications.....	172
3.1.6	Nameplate and Label	179
3.2	Installation	180
3.2.1	Cautions during Installation	180
3.2.2	Installation Environment	182
3.2.3	Hardware Installation.....	183
3.2.4	Power On/Off Controller Switch.....	192
3.3	Interface	193
3.3.1	Flange I/O	193
3.3.2	Connecting Controller I/O.....	200
3.3.3	Network Connection	215
3.4	Transportation	219
3.4.1	Caution during Transportation	219
3.4.2	Package Specifications	220
3.4.3	Pose for Robot Transportation	220
3.5	Maintenance	221
3.6	Disposal and Environment.....	222
4	PART 4. User Manual	223

4.1	System Power On/Off	223
4.1.1	When using a teach pendant	223
4.1.2	System Booting	224
4.2	Program screen configuration	226
4.2.1	Home Screen Overview	227
4.2.2	Status window	229
4.2.3	Status Display Area	230
4.2.4	Work Screen Area	231
4.2.5	Main Menu	231
4.3	Understanding the robot	232
4.3.1	What is Euler Angle A, B, C?	232
4.3.2	What is Singularity?	235
4.3.3	Functional Limits of each Robot Series	237
4.4	Servo On	240
4.5	I/O and Communication	241
4.5.1	I/O Status Check	241
4.5.2	I/O Test.....	244
4.5.3	Modbus Test.....	245
4.5.4	Status > Slave Monitoring.....	245
4.6	What is a Workcell Item?	246
4.6.1	Add Workcell Item	248
4.6.2	Deprecated Workcell Item	249
4.6.3	Unavailable Workcell Items	251
4.7	Utilizing Workcell Manager	252
4.7.1	Robot Safety Setting.....	252
4.7.2	Robot Setting	253
4.7.3	End Effector Setting.....	279
4.7.4	Machine Tool Setting	285
4.7.5	Peripheral Setting	286
4.8	Tool Setting	287
4.9	Manual Robot Operation	288
4.9.1	Jog Function	288
4.9.2	Safety Recovery Mode.....	305
4.9.3	Backdrive Mode.....	307

4.9.4	Hand-Guiding Operation	309
4.10	Automatic Robot Operation	316
4.10.1	Robot Teaching and Execution.....	316
4.10.2	Task Builder	316
4.10.3	Task Writer	344
4.10.4	Task Execution and Stopping.....	352
4.10.5	Load Saved Tasks	353
4.11	Environment Setting	354
4.11.1	Language Setting	354
4.11.2	Date and Time Setting.....	354
4.11.3	Robot Setting	354
4.11.4	Change and Disable Password	361
4.11.5	User Role Setting.....	362
4.11.6	Network Setting	363
4.11.7	System Update	366
4.11.8	Check and Enter Robot License Code	368
4.11.9	Check Log	369
4.11.10	Factory Reset	370
4.11.11	Screen Saver Mode Setting	370
4.11.12	Idle Servo Off	371
4.11.13	Backup & Restore	371
4.11.14	Motion Power Limit	373
4.11.15	Workcell & Skill Installation and Removal.....	374
4.11.16	KT Smart Factory Setting Screen	374
5	Appendix	375
5.1	Appendix. System Specification	375
5.1.1	Manipulator	375
5.1.2	Controller	382
5.1.3	Teach pendant	384
5.2	Appendix. Protected AC Controller (CS-01P).....	385
5.2.1	Product Introduction (CS-01P).....	385
5.2.2	Installation (CS-01P).....	387
5.3	Appendix. DC Controller	393
5.3.1	DC Controller (CS-02)	393

5.4	Appendix. H-Series Handling Guide	403
5.4.1	Quick Guide	403
5.5	Appendix. Doosan Robot Allowable Torque.....	408
5.5.1	Doosan Robot Allowable Torque	408
5.6	Appendix. Troubleshooting Guide	409
5.6.1	Application Recovery Mode Screen	409
5.6.2	Series Compatibility Error Screen	410
5.6.3	Releasing Stop due to Space Limit and Zone Violations.....	413
5.7	Appendix. Welding Work Overview	415
5.7.1	EtherNet/IP Interface Welding Machine Connection Example	415
5.7.2	Flow of Welding Work Utilizing Doosan Robots.....	415
5.8	Appendix. DART Platform Installation Requirement (minimum, recommended)	418
5.8.1	Minimum/Recommended Requirement	418
5.8.2	DART Platform Resolution support.....	418

- **Preface**

Thank you for choosing this Doosan Robotics product. Before installing the product, please read through this manual and follow the instructions for each installation process provided in this manual. The contents of this manual are current as of the date this manual was written, and product-related information may be modified without prior notification to the user.

- **Copyright**

The copyright and intellectual property rights of the contents of this manual are held by Doosan Robotics. It is therefore prohibited to use, copy, or distribute the contents without written approval from Doosan Robotics. In the event of abuse or modification of the patent rights, the user will be solely responsible for the consequences.

While the information in this manual is reliable, Doosan Robotics is not responsible for any damage that occurs due to errors or typos. The contents of this manual may be modified according to product improvement without prior notification.

For details of updated manuals, refer to the robot LAB website (<https://robotlab.doosanrobotics.com/>).

© Doosan Robotics Inc., All rights reserved

- **Open Source Software License Information (OSS)**

The software installed in this product was developed based on free/open source software.

Details about the free/open source software license can be found on the OSS use page on the Doosan Robotics website (www.doosanrobotics.com/kr/oss/license¹).

For related inquires, contact the Marketing Department of Doosan Robotics (marketing.robotics@doosan.com²).

1. <https://www.doosanrobotics.com/kr/oss/license>



2. <mailto:marketing.robotics@doosan.com>

1 PART 1. Safety Manual

The Safety provides safety information the user must be aware of before installing or operating the robot. All robots have risks of high voltage, electricity, and collision. Therefore, in order to minimize the risk of injuries and mechanical damage, one must observe the basic safety cautions while operating the robot and using related parts. To protect user safety and prevent property loss, make sure to read and follow the instructions carefully. The contents of the manual and specifications of the product may change for product and performance improvements.

1.1 Manual Indication Conventions



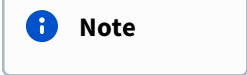

To communicate safety precautions related to the use of the product, the following symbols are indicated in this manual.

Symbol	Name	Description
	Danger	Failure to observe instructions with this symbol may result in serious accidents that could result in death or serious injury to the operator.
	Warning	Failure to observe instructions with this symbol may result in serious accidents that could result in death or serious injury to the operator.
	Caution	Failure to observe instructions with this symbol may result in product damage or cause injury to the operator.
	Note	This is additional information to help the user.

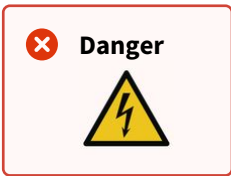
1.2 Safety Symbols

Among the symbols used in this manual, symbols related to user safety are as follows:

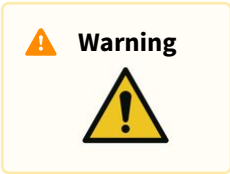
Symbol	Description
	This symbol means that immediate hazards can occur due to electrical conditions such as high voltage. Failure to observe instructions with this symbol may result in serious accidents that could result in death or serious injury to the operator.

Symbol	Description
	This symbol means that immediate hazards can occur. Failure to observe instructions with this symbol may result in serious accidents that could result in death or serious injury to the operator.
	This symbol means that potentially dangerous situations can occur due to electrical conditions such as high voltage. Failure to observe instructions with this symbol may result in serious accidents that may cause serious injury to the operator.
	This symbol means potentially dangerous situations can occur. Failure to observe instructions with this symbol may result in serious accidents that may cause serious injury to the operator.
	This symbol means dangerous situations can occur due to overheating. Failure to observe instructions with this symbol may result in serious accidents that may cause serious injury to the operator.
	The product may become damaged or the operator may suffer injury.

1.3 General Instructions

This chapter describes general danger and warning items related to operating the robot.

Warning



- If the robot is installed with electrical devices, install the robot referring to the Installation Manual.

Warning



- If a device is installed on the tool during robot installation, make sure to use appropriate bolts.
- Suitable safety measures, such as safety fences, must be implemented to protect the staff and robot during installation.
- Never operate a damaged robot.
- Make sure to connect safety protection equipment with a safety interface. If such equipment is connected to a general interface, the integrity of safety functions may not be guaranteed.
- If the robot collides with an external object, a significant impact may be generated. The impact the robot receives is proportionate to the kinetic energy, so higher speeds and high payload can generate large impacts. Make sure to maintain a safe speed and payload during operation in collaborative spaces.
- If the robot axis must be rotated when the robot is not operated, it can be rotated at a torque greater than 400 Nm.
- Modifying the robot without prior approval may cause critical breakdowns and accidents.

 **Caution**



- Operating the robot and controller for an extended period of time generates heat. Do not touch the robot with bare hands after operating for an extended period of time. Before performing work that requires touching the robot, such as tool installation, leave the robot for more than 1 hour after turning off the power of the control unit to cool down the robot.

 **Caution**



- Do not expose the robot to powerful magnetic fields. It may cause damage to the robot.
- If the power plug is disconnected or the power is shut off during robot and controller operation, robot and controller failure can occur.
- Do not use the controller being laid. To avoid getting a hand caught in the door by accident, make sure to keep it upright while working with the door open.

1.4 Precautions for Use

 **Danger**



- Do not operate the robot if the robot is abnormal. The user may be injured.
- Do not put fingers inside the controller with power supplied. Live cables are connected, which may lead to electrocution or injury.

- Do not modify the robot. Doosan Robots is not responsible for any issues that occur due to unauthorized modification.
- Do not enter the robot's operation area or touch the robot when it is operating. This may lead to colliding with the robot, resulting in damage to the robot or injury to the individual.

Warning

- Make sure to read and understand the manuals for all equipment installed.
- To prevent accidents by getting caught by the robot, do not wear loose clothing or accessories when operating the robot. Tie long hair to prevent accidents with hair getting caught by the robot.
- Before operating the robot, comprehensive risk assessment must be performed.
- Safety-related parameters must be determined through the comprehensive risk assessment, and safety parameter settings and the operation of safety functions must be verified before operating the robot.
- Before starting robot operation (Jogging, handguiding, running task program, etc.), make sure that the actual payload and installation are correct and that the actual pose of robot is identical to the pose on screen.
- Nudge and Hand-guiding must only be used if risk assessment approves its use.
- If an error occurs on the controller or the teach pendant, activate the emergency stop function, identify the cause of the error, find the error code on the log screen and contact the supplier.
- Make sure to become completely familiar with the robot user manual prior to operating the robot.
- If the teaching pendant warns the user of a critical error, immediately engage the emergency stop switch, identify the cause of the error, resolve the error and then resume robot operation. If the critical error cannot be resolved, contact the sales agent or robot supplier.
- Direct teaching must only be performed in safe environments. Do not operate the robot if there are sharp edges or jamming near the tool and its surroundings.
- Before performing direct teaching, make sure accurate inputs (tool length, weight, center of gravity) are made. If inputs are different from the tool specification, direct teaching error or malfunctioning can occur.
- Neglecting to verify the tool associated settings can result in injury to personnel and/or property damage. Always verify the actual tool and tool settings are correct.
- To ensure user safety, the maximum speed of the TCP and/or joints may be limited during direct teaching. If the limit is exceeded, the protective stop function activates.
- Enable/disable the direct teaching function when the robot has completely stopped. If the direct teaching function is enabled/disabled during robot operation, malfunctions may occur.

Caution

- Take caution of the robot's movement when using the teach pendant. Failure to do so may lead to colliding with the robot, resulting in damage to the robot or injury to the individual.

- Collision with an object generates considerable kinetic energy, leading to dangerous situations. This energy is proportionate to the speed and payload. (Kinetic Energy = $1/2 \text{ Mass} \times \text{Speed}^2$)
- Combining different machines may increase existing risks or create new risks. When a robot is integrated into a system, perform risk assessment of the entire system.
- If different safety levels and emergency stop performance levels are required, always select the higher level.
- If a machine that can cause damage to the robot is integrated, it is recommended to individually test all functions and robot programs.
- It is recommended to test the robot program by designating temporary waypoints outside another machine's workspace. Doosan Robotics is not responsible for damages that occur due to programming error or robot malfunctioning, as well as damage to the equipment.
- If the power plug is disconnected or the power is shut off during robot and controller operation, robot and controller failure can occur.
- For information about additional modules, refer to corresponding manuals.

1.5 Product Usage

This is an industrial product designed specifically for purposes of transferring and assembling objects by attaching components to products using tools, and it must be operated in the conditions specified in its specifications.

This product features special safety functions designed for the purpose of collaborating with human operators, and it operates with human operators without specific boundaries. Conduct work with the system only when all applications, including the tool, workpiece, boundary and other equipment, are confirmed to have no harm.

The following uses are considered inappropriate because they exceed the boundaries of the product's intended purpose. Doosan Robotics will not be held responsible for any damage and malfunctioning of the robot, property losses and injuries to users due to such inappropriate uses.

- Use in an environment with potential explosions
- Use in application related to medicine and human lives
- Use in transporting humans and animals
- Use without risk assessment
- Use in locations where performance and operation environment specifications are not met
- Use in environments with insufficient safety functions
- Use of the robot as a step to stand on
- Use under conditions beyond the IEC International Standard for Electromagnetic Compatibility in Industrial Environments

1.6 Risk Assessment

legally mandatory in most countries. In addition, safety assessment of robot installation changes according to the overall system integration method, so it is impossible to perform risk assessment solely with the robot.

In order to perform risk assessment, the administrator overseeing the overall system establishment must install and operate the robot according to ISO12100 and ISO10218-2. In addition, the administrator can refer to the technical specification, ISO/TS 15066.

Risk assessment must consider the overall work process in terms of the overall life cycle of the robot application. Key objectives of risk assessment are as follows:

- Robot setting and work teaching for robot operation
- Troubleshooting and maintenance
- Proper robot installation

Before supplying power to the robot arm, make sure to perform a risk assessment. Setting appropriate safety settings and identifying the need for additional emergency stop buttons and other protective measures are parts of risk assessment.

Identifying appropriate safety settings is a critical aspect of developing a collaborative robot application. For more information, refer to the corresponding chapter of the manual.

Some safety functions are designed specifically for collaborative robot applications. These functions can be set up through safety function settings, and they are optimized for responding to specific risks identified through the risk assessment performed by the integrator.

The safety functions of the collaborative robot can be set up in the safety setting menu, and they offer the following features:

- Force and power limitation: Limits the stopping force and pressure of the robot in case of collisions between the robot and a worker
- Momentum limitation: Limits the energy and impact load by reducing the speed of the robot when a collision between the robot and a worker occurs
- Joint position and TCP limitation: Limits robot movement to prevent moving towards specific body parts of users such as the neck or head
- TCP and tool pose limitation: Limits certain areas or characteristics of a tool and workpiece to minimize related risks (i.e., limits the movement of sharp edges of workpieces aimed at users)
- Speed limitation: Limits robot movement to stay at low speed in order to secure time for the user to avoid a collision before a collision between the robot and a worker occurs

Applying appropriate safety settings is considered to be the same as fixing the robot to a specific location and connecting it to a safety-related I/O. For example, setting password protection can prevent unauthorized safety setting changes by individuals not approved by the system integrator.

Key items to note when performing risk assessment of the collaborative robot application are as follows:

- Severity of individual potential collisions
- Probability of individual potential collision occurrence
- Probability of individual potential collision avoidance

If the robot is installed on a non-collaborative robot application that cannot sufficiently remove risks using its internal safety functions (e.g., use of dangerous tool), the system integrator must decide to install additional

protection devices during risk assessment (e.g., use of protection devices capable of protecting the integrator during installation and programming).

1.7 Potential Risks

- Jamming fingers between the manipulator base and mount
- Jamming limbs between the Link 1 and Link 2 (between Joint 3 (J3) and Joint 4 (J4))
- Jamming limbs between Joint 1 and Joint 2 (J1 and J2) and Joint 5 and Joint 6 (J5 and J6)
- Penetration of skin by sharp edges or surfaces of the tool
- Penetration of skin by sharp edges or surfaces of objects in the operating space of the robot
- Contusion caused by robot movement
- Bone fracturing due to movement between heavy payload and hard surface
- Accidents that occur due to loosening of bolts securing the robot flange or tool
- Object falls from the tool due to inappropriate grip or sudden power shortage
- Accidents that occur due to mistaking an emergency stop button of different equipment
- Errors that occur due to unauthorized safety parameter modification

1.8 Robot Mode and State

The operation modes of the robot consist of Manual Mode, where the user controls the robot directly, and Auto mode, where the robot operates without direct user control.

1.8.1 Manual Mode

This is the mode in which the robot operates according to direct user control. The robot only operates when a button related to an action is pressed, and releasing the button results in stopping the corresponding action.

- In Manual Mode, the TCP movement speed is limited to less than 250 mm/s according to the Robot Safety Regulations.
However, during Handguiding, the TCP speed and joint speed are limited to less than the thresholds of Reduced status set in **WCM > Robot > Robot Limits**
- If risk assessment results indicate that a 3-position Enable Switch is necessary, the 3-position Enable Switch can be connected through the I/O by the setting in the **WCM > Robot > Safety I/O**. In this case, the Enable Switch must be placed in the center-enable position to allow robot operation in Manual Mode and Servo On.

In Manual Mode, it is possible to configure robot peripherals in the Workcell Manager or to program robot tasks in Task Builder and Task Writer, and if the robot cannot be operated normally for reasons such as the robot exceeding the safety threshold, the Recovery function can be performed to restore normal operation.

1.8.2 Automatic Mode

This is the mode in which the robot operates without direct user control. The robot will execute the programmed task or predefined sequence with a simple operation command and without additional user input.

Task Builder or **Task Writer** can verify the programmed task in virtual mode, execute it in actual operation, and perform robot tool weight and auto weight center measurement functions.

- If risk assessment results indicate that a 3-position Enable Switch is necessary, the 3-position Enable Switch can be connected through the I/O by the setting in the **WCM > Robot > Safety I/O**. In this case, the Enable Switch must be placed in the center-enable position to allow Play or Start, Resume and Servo On in Automatic Mode.

1.8.3 Other Mode

Unlike normal modes such as manual mode and automatic mode, this is exceptional mode.

This mode includes special states such as controller booting, initializing and states related to Backdrive at which you can push robot by hand without drive power.

1.8.4 Status and Flange LED Color for Each Mode

Manual Mode

Mode	State	Description	Flange and/or Base LED
Manual	Manual Standby	<ul style="list-style-type: none"> • This is the default status of teaching. • Workcell Manager, Task Builder and Task Writer can be used to configure the work condition or perform task programming. • It monitors the stop status with Safe Operating Stop (SOS). 	Blue
	Manual Jogging	<ul style="list-style-type: none"> • The jog function is used to operate the robot. 	Blue Blinking
	Manual Handguiding	<ul style="list-style-type: none"> • The robot can be operated manually during teaching. 	Cyan Blinking
	Recovery Standby	<ul style="list-style-type: none"> • Recovery in progress. • All safety functions except for axis and TCP speed monitoring are disabled during recovery. • It monitors the stop status with Safe Operating Stop (SOS). 	Yellow Blinking
	Recovery Jogging	<ul style="list-style-type: none"> • The jogs of each axis can be used to correct the exceeded safety threshold. 	Yellow Blinking

Mode	State	Description	Flange and/or Base LED
	Recovery Handguiding	<ul style="list-style-type: none"> The robot can be moved directly by hand to correct the exceeded safety threshold. 	Yellow Blinking
	Interrupted	<ul style="list-style-type: none"> The system is in a protective stop state due to protective stop input, exceeding the safety threshold, etc. It monitors the stop status with Safe Operating Stop (SOS). A yellow Protective stop pop-up will appear. After removing the cause of the protective stop, if you press the Reset button, the robot state will be converted to Manual Standby state and the pop-up will disappear. If it is not possible to release the safety limit exceeding without moving the robot, press the Recovery button to enter the safety recovery mode, and after moving the robot, Interrupted can be released. If it is impossible to release the protective stop input from the Protective Device, press the Safety I/O button to cancel the protective stop input setting. 	Yellow
	Servo Off	<ul style="list-style-type: none"> The servo is off due to emergency, protective stop input, stop or exceeded safety threshold. It is identical to Safe Torque Off (STO). Servo On is possible only when all causes of emergency stop or protective stop are removed. If it is not possible to release the safety limit exceeding without moving the robot, it can be released by moving the robot after Servo On in the safety recovery mode screen. If it is impossible to release the protective stop input from the Protective Device, cancel the protective stop input setting in the Safety I/O setup menu. 	Red (M/H-Series)

Auto Mode

Mode	State	Description	Flange and/or Base LED
Auto	Auto Standby	<ul style="list-style-type: none"> The Teach Pendant UI is in the actual mode execution screen in a single work space. Pressing the "Execute" button will execute the task program. White is displayed for a Standalone Zone, green is displayed for a Collaborative Zone.. 	White/Green
	Auto Running	<ul style="list-style-type: none"> The task program is being executed. White is displayed for a Standalone Zone, green is displayed for a Collaborative Zone., and white and yellow are displayed by turns for a High Priority Zone 	White Blinking / Green Blinking / ss White and yellow Flashing alternately
	HGC (HandGuide Control) Standby	<ul style="list-style-type: none"> The Handguiding command is executed during task program execution. The system waits until the user presses the "Handguiding" button. It monitors the stop status with Safe Operating Stop (SOS). 	Cyan
	HGC Running	<ul style="list-style-type: none"> The robot pose can be changed by pressing the "Handguiding" button. After the robot stops, enter HGC End & Resume signal through the Safety IO to set Auto Running and then continue executing the task program. 	Cyan Blinking
	Auto-measure	<ul style="list-style-type: none"> The weight and center of gravity point of the end effector are measured automatically. Please note that the safety monitoring functions of the robot are disabled during auto-measuring. 	Yellow Blinking

Mode	State	Description	Flange and/or Base LED
	Interrupted	<ul style="list-style-type: none"> The system is in a protective stop state due to protective stop input, exceeding the safety threshold, etc. It monitors the stop status with Safe Operating Stop (SOS). A yellow Protective stop pop-up will appear. After removing the cause of the protective stop, if you press the Reset button, the robot state will be converted to Manual Standby state and the pop-up will disappear. If it is not possible to release the safety limit exceeding without moving the robot, press the Recovery button to enter the safety recovery mode, and after moving the robot, Interrupted can be released. If it is impossible to release the protective stop input from the Protective Device, press the Safety I/O button to cancel the protective stop input setting. 	Yellow
	Servo Off	<ul style="list-style-type: none"> The servo is off due to emergency, protective stop input, stop or exceeded safety threshold. It is identical to Safe Torque Off (STO). Servo On is possible only when all causes of emergency stop or protective stop are removed. If it is not possible to release the safety limit exceeding without moving the robot, it can be released by moving the robot after Servo On in the safety recovery mode screen. If it is impossible to release the protective stop input from the Protective Device, cancel the protective stop input setting in the Safety I/O setup menu. 	Red (M/H-Series)

Other Mode

Mode	State	Description	Flange and/or Base LED
-	Backdrive Hold	<ul style="list-style-type: none"> All brakes of 6 joints are engaged, and Backdrive motion is locked. 	Yellow Blinking

Mode	State	Description	Flange and/or Base LED
	Backdrive Release	<ul style="list-style-type: none"> Break of one or more joint(s) is released due to the selection of brake release. The brake(s) will not lock by itself. Use caution as the robot and/or end-effector may fall unless all brakes are engaged again. 	Yellow Blinking
	Backdrive Servo Off	<ul style="list-style-type: none"> The servo is off due to emergency stop or exceeded joint speed threshold during Backdrive Motion. It is identical to Safe Torque Off (STO). 	Red (M/H-Series)
	Initializing	<ul style="list-style-type: none"> The controller is booting and the robot is initialized. 	Red Blinking

1.9 Product Warranty and Responsibility

Doosan Robotics (hereinafter referred to as “Doosan” or “Manufacturer”) offers a restricted warranty as stipulated in this warranty certificate for all robot systems (collectively “robot”) and parts of the system (excluding parts that are exceptions or restricted according to the terms and conditions below) sold through Doosan or official sales agents. The warranty stipulated by this warranty certificate is a restricted warranty, and it is the only warranty provided by the Manufacturer. All warranty items shall be handled according to the conditions listed below.

1.9.1 Scope of Warranty

The material and manufacturing defects of each robot and its parts (collectively, “Doosan Products”) are subject to the warranty provided by the Manufacturer. This warranty is only offered to the end user (hereinafter referred to as “Customer”). The warranty period is 1 year starting from the date when the robot was installed.

The scope of this warranty limits the Manufacturer's only responsibility for all Doosan products and the Customer's only remedy to the repair or replacement of defective Doosan products.

Doosan does not compensate any or all financial, operation or productions losses, any or all indirect losses such as damage to other equipment, and any or all deliberate, special or consequential losses that occur due to defects of Doosan Products.

1.9.2 Restrictions and Exceptions of Warranty

To maintain the warranty, thorough maintenance procedures stipulated by the Manufacturer must be observed and recorded. This warranty is voided if the Manufacturer determines that the user failed to observe the following stipulated procedures.

- If a Doosan Product is inappropriately handled or used by the user

- If parts or S/W not provided by Doosan are installed
- If a Doosan Product is incorrectly repaired or maintained by an unofficial repair technician or unauthorized individuals
- If the user modified a Doosan Product without prior approval from the Manufacturer
- If a Doosan Product was used for non-industrial or personal purposes
- If the life cycle of consumables has ended
- If the warranty claim is made after the warranty period
- If the breakdown is caused by natural disasters (fire, flood, abnormal power, etc.)

This warranty does not apply to damages caused by external circumstances the Manufacturer does not have any control over such as theft, intentional destruction, fire, natural disasters, war or act of terrorism.

Notwithstanding the exceptions or restrictions of this warranty, this warranty does not include any warranties where a Doosan Product satisfies the buyer's production standards or miscellaneous requirements, or operates without any errors or without any interruption. The Manufacturer does not assume responsibility for any uses by the buyer, and the Manufacturer does not assume any responsibility for defects other than repair or replacement such as defects in design, production, operation and performance.

1.9.3 Transfer

This warranty is included in the warranty period, and if the Doosan robot is sold to a different individual through a private transaction, the warranty can also be transferred. However, the warranty is only valid if the Manufacturer is notified of this transaction, and the warranty period is still in effect. The assignee of this warranty must observe all conditions stipulated in this warranty.

1.9.4 Contact

marketing.robotics@doosan.com³

1.10 Safety Function

Users/system integrators can make use of the various safety functions, including safety-rated stop function, monitoring function and interface function, to protect operators and machines, and can also connect other machines and safety/protection equipment.

Each safety-rated stop function, monitoring function and interface function satisfy Category 3, Performance Level d(PL d) defined by ISO 13849-1 and Hardware Fault Tolerance 1, Safety Integrity Level 2(SIL 2) defined by IEC 62061.

The joint-level operated safety functions of Doosan Robotics uses the safety functions described in IEC 61800-5-2.

3. <mailto:marketing.robotics@doosan.com>

Note

- Work cells must be set using the safety functions and interface according to the risk assessment performed on the corresponding robot application by the system integrator, and refer to this manual for information required for this..
- If the safety systems of the robot detect system defects, such as hardware defects including emergency stop circuit shortage, position sensor damage or control communication error, Stop Category 0 is immediately initiated.
- Meanwhile, if the safety systems of the robot detect violations during safety monitoring, such as pressing the emergency stop switch, protective stop signal input, detection of external impact, or physical parameters (robot/TCP position, speed, momentum) exceeding set parameters, the system stops the robot using the mode set as the stop mode setting in the safety setting menu. (Selects Stop Category 0, 1 or 2)
- For information on the time and stopping distance until the robot comes to a full stop from the moment the above error or violation occurs, refer to [Stop Distance and Stop Time](#)(p. 58). This time must be considered as part of the risk assessment performed by the system integrator.
- In special cases (collision detection, TCP Force Violation), a Safety Stop Mode that stops the robot after accepting the external force for 0.25 seconds after event occurrence can be used to avoid clamping situations where limbs are jammed between the fixated jig/workpiece and the robot. (RS1 Stop Mode)
- The safety setting menu can set various safety functions to limit the movement of joints, robot and TCP. TCP means the location of the output flange center point added by the TCP offset.

1.10.1 Safety-rated Stop Subfunction

Safety-rated stop subfunction is used to stop the robot when [Safety-rated Monitoring Function](#)(p. 25) detects limit violation, when a stop signal is received from the dedicated input terminal of [Safety-rated Stop Function](#)(p. 24), or when a stop signal is received from the configurable input terminal of [Safety-rated I/O](#)(p. 28) set as one of the Safety-rated Stop Subfunctions.

Note

- PFHd (Probability of a dangerous Failure per Hour): The probability of dangerous safety-related system/subsystem failures occurring in an hour
- PL (Performance Level): The performance level of safety-related components (SRP/CS) of control system defined by ISO 13849-1
- SIL (Safety integrity level): the safety integrity level of safety-related electronic control systems (SRECS or SCS) defined by IEC 62061
- Stop Category: The category of stop functions defined by IEC 60204-1

	Safety Function	Description	PFHd	PL, SIL
1	STO (Safe Torque Off) & SBC (Safe Brake Control)	<p>It is the safety stop function corresponding to Stop Category 0, and it immediately cuts motor power to all joint modules.</p> <p>With motor power down, the axis will continue to rotate due to inertia, so the brakes must be operated simultaneously to stop with frictional force of the brake.</p> <ul style="list-style-type: none"> As the motor power is cut off, the robot can be operated after releasing the stop function and setting the Servo On. For more information about servo on methods, refer to Servo On(p. 240). The robot brake is used for maintaining the current pose when driving force is lost (i.e., power off, etc.) not for deceleration. Frequently using STO can result in brake wear or decelerator durability loss, so it is recommended to use SS1 unless necessary. 	2.54E-8 /h	PL e Cat. 4 SIL 3
2	SS1 (Safe Stop 1)	<p>It is the safety stop function corresponding to Stop Category 1, and it decelerates all joints as much as possible to stop them, cuts the motor power off and activates the brake to maintain the stopped state.</p> <ul style="list-style-type: none"> If deceleration is not sufficient during stopping, the method is set to STO stop. Power is cut off after deceleration, and like STO, the robot can be operated after releasing the stop function and setting the Servo On. For more information about Servo On methods, refer to Servo On(p. 240). 	1.41E-7 /h	PL d Cat. 3 SIL 2
3	SS2 (Safe Stop 2)	<p>It is the safety stop function corresponding to Stop Category 2, and it decelerates all joints as much as possible to stop them, and SOS stopped state monitoring function is engaged.</p> <ul style="list-style-type: none"> If deceleration is not sufficient during stopping, the method is set to STO stop. All joints are stopped with maximum deceleration by a Stop Mode corresponding to Stop Category 2, and SOS (Safe Operating Stop) is engaged. 	1.41E-7 /h	PL d Cat. 3 SIL 2

	Safety Function	Description	PFHd	PL, SIL
4	Reflex Stop (RS1)	<p>It is the safety stop function corresponding to Stop Category 2, and it utilizes Floating Reaction (a function to comply with the external force for a moment after the collision is detected) to respond to external force, and Safe Operating Stop (SOS) is engaged.</p> <ul style="list-style-type: none"> If excessive location, change in direction or speed is detected during Floating Reaction, or if deceleration is not done appropriately during stopping, STO stop is engaged. 	1.41E-7 /h	PL dCat. 3 SIL 2

1.10.2 Safety-rated Stop Function

	Safety Function	Safety Function Trigger Condition Triggering Event	Intended Action Intended Result	PFHd	PL, SIL
1	Emergency Stop	<p>If the Emergency Stop switch connected to the TBSFT EM terminal is pressed</p> <p>If the Emergency Stop switch of the teach pendant is pressed</p>	<p>Emergency Stop is engaged according to the configured Safety Stop Mode.</p> <ul style="list-style-type: none"> STO or SS1 	2.54E-8 /h	PL e Cat. 4 SIL 3
2	Protective Stop	If the protective device connected to the TBSFT PR terminal is activated	<p>Emergency Stop is engaged according to the configured Safety Stop Mode.</p> <ul style="list-style-type: none"> STO, SS1, or SS2 	1.41E-7 /h	PL d Cat. 3 SIL 2

How to restart work after protective stop

If the robot tool center point (TCP) is within the **Collaborative Zone** and if the **Nudge** function is enabled, the user can apply force to the robot directly (Nudge) to restart work. For more information, refer to [Collaborative Zone Settings](#)(p. 267) and [Nudge](#)(p. 39).

Emergency Stop

The user can make use of the emergency stop button to stop the system in emergency situations. In emergency situations, press the Emergency Stop button in the top right corner of the teach pendant to immediately stop the system.

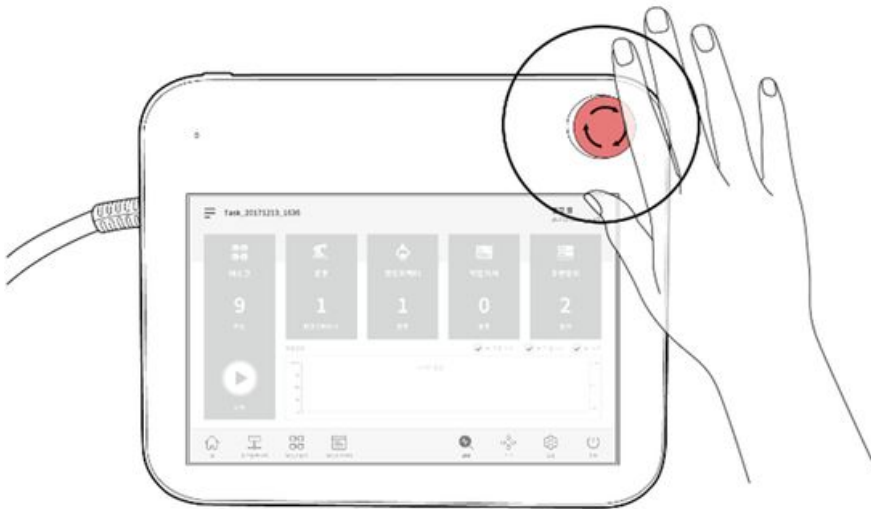

i Note

- The Emergency Stop function must be used as complementary protective measure, not as a safeguarding measure.
- **SS1 (Safe Stop 1)** is set as the default mode for the Safety Stop Mode of Emergency Stop.
- When a robot application risk assessment result is needed, you can install additional Emergency Stop buttons.
- The Emergency Stop button must comply with IEC 60947-5-5.
- If an Emergency Stop occurred through the Emergency Stop button connected to the Safety I/O port, the button capable of accessing the screen for Safety Input setting at the bottom of the emergency stop popup window is enabled.

Protective Stop

The robot also features Protective Stop function which can stop the robot using pressure sensitive protective equipment, such as safety mats, or electro-sensitive protective equipment, such as light curtain laser scanners.

For more information about connecting protective devices, refer to [Setting the Terminal Block for Contact Input \(TBSFT\)](#)(p. 201) and [Setting the Configurable Digital I/O \(TBCI1 - 4,TBCO1 - 4\)](#)(p. 204).

1.10.3 Safety-rated Monitoring Function

Doosan Robotics provides safety-rated monitoring function which can be used as a risk reduction measure for risk assessments. The limit of each monitoring function can be configured through **Workcell Manager > Robot > Robot Limits** of the Teach Pendant UI.

i Note

- Safety limits is the condition where the safety-rated monitoring function triggers the stop function. When stop is completed, the position of the robot and force applied externally may differ from the configured safety limit.
- PFHd (Probability of a dangerous Failure per Hour): The probability of dangerous failures of safety-related system/subsystem per hour
- PL (Performance Level): The performance level of safety-related components (SRP/CS) of control system according to ISO 13849-1
- SIL (Safety integrity level): The safety integrity level of safety-related electronic control systems (SRECS or SCS) according to IEC 62061

	Safety Function	Safety Function Trigger Condition Triggering Event	Intended Action Intended Result	PFHd	PL, SIL
1	SOS (Safe Operating Stop)	The current position is maintained with power supplied to the motor and the brake disengaged (Servo ON state). If the angle of one axis exceeds a certain angle when stopped	STO	1.41E-7 /h	PL d Cat. 3 SIL 2
2	SLP Joint Angle Limit SLP (Joint Angle Limit)	If any of the axis angles exceed the configured limit	Emergency Stop is engaged according to the configured Safety Stop Mode. • STO, SS1, or SS2	1.41E-7 /h	PL d Cat. 3 SIL 2
3	SLS Joint Speed Limit SLS (Joint Speed Limit)	If any of the axis speeds exceed the configured limit	Emergency Stop is engaged according to the configured Safety Stop Mode. • M series: STO, SS1, or SS2 • H series: SS1, or SS2	1.41E-7 /h	PL d Cat. 3 SIL 2
4	SLT Joint Torque Limit SLT (Joint Torque Limit)	If the torque applied to each axis exceeds the predefined limit	Emergency Stop is engaged according to the configured safety stop mode. • STO	1.94E-7 /h	PL d Cat. 3 SIL 2

	Safety Function	Safety Function Trigger Condition Triggering Event	Intended Action Intended Result	PFHd	PL, SIL
5	Collision Detection Collision Detection	If any of the torques applied to each axis exceed the limit for configured collision detection sensitivity	Emergency Stop is engaged according to the configured Safety Stop Mode. <ul style="list-style-type: none"> • M series: STO, SS1, SS2, or RS1 • H series: SS1, SS2, or RS1 • Stop Mode for Collaborative Zone and Standalone Zone can be set individually. 	1.94E-7 /h	PL d Cat. 3 SIL 2
6	TCP/Robot Position Limit TCP/Robot Position Limit	If the TCP or robot (including Tool Shape) exceeds or violates the configured range of the space limit	Emergency Stop is engaged according to the configured Safety Stop Mode. <ul style="list-style-type: none"> • STO, SS1, or SS2 	1.41E-7 /h	PL d Cat. 3 SIL 2
7	TCP Orientation Limit TCP Orientation Limit	If the difference between the set direction and the TCP direction within Tool Orientation Limit Zone exceeds the configured limit	Emergency Stop is engaged according to the configured Safety Stop Mode. <ul style="list-style-type: none"> • M series: STO, SS1, or SS2 • H series: SS1, or SS2 	1.41E-7 /h	PL d Cat. 3 SIL 2
8	TCP Speed Limit TCP Speed Limit	If the TCP speed exceeds the configured limit	Emergency Stop is engaged according to the configured Safety Stop Mode. <ul style="list-style-type: none"> • M series: STO, SS1, or SS2 • H series: SS1, or SS2 	1.41E-7 /h	PL d Cat. 3 SIL 2

	Safety Function	Safety Function Trigger Condition Triggering Event	Intended Action Intended Result	PFHd	PL, SIL
9	TCP Force Limit TCP Force Limit	If the external force applied to the TCP exceeds the configured limit	Emergency Stop is engaged according to the configured Safety Stop Mode. <ul style="list-style-type: none"> • M series: STO, SS1, SS2, or RS1 • H series: SS1, SS2, or RS1 • Stop Mode for Collaborative Zone and Standalone Zone can be set individually. 	1.94E-7 /h	PL d Cat. 3 SIL 2
10	Robot Momentum Limit Robot Momentum Limit	If the momentum of the robot exceeds the configured limit	Emergency Stop is engaged according to the configured Safety Stop Mode. <ul style="list-style-type: none"> • M series: STO, SS1, or SS2 • H series: SS1, or SS2 	1.41E-7 /h	PL d Cat. 3 SIL 2
11	Robot Power Limit Robot Power Limit	If the mechanical power of the robot exceeds the configured limit	Emergency Stop is engaged according to the configured Safety Stop Mode. <ul style="list-style-type: none"> • M series: STO, SS1, or SS2 • H series: SS1, or SS2 	1.94E-7 /h	PL d Cat. 3 SIL 2

1.10.4 Safety-rated I/O

Doosan Robotics provides a safe-rated input interface to which safety protection devices, protection devices, emergency stop switches, control devices, etc., can be connected. In addition, a safety-rated output interface is provided that outputs the robot mode and status information as well as whether the TCP is inside various types of safe areas.

Note

- PFHd (Probability of a dangerous Failure per Hour): The probability of dangerous failures of safety-related system/subsystem per hour
- PL (Performance Level): The performance level of safety-related components (SRP/CS) of control system according to ISO 13849-1
- SIL (Safety integrity level): The safety integrity level of safety-related electronic control systems (SRECS or SCS) according to IEC 62061

	Safety Function	Description	PFHd	PL, SIL
1	Safety IO	A duplexed interface for safety related signal input and output If the input signals do not match or if duplexed output signal feedbacks do not match, it stops the robot and displays an error message.	2.7E-8 /h	PL d Cat. 3 SIL 2

It is the safety-rated input and output, and it offers following functions: For more information, refer to [Safety I/O](#)(p. 33).

Safety Input	Safety Output
<p>Emergency Stop (L), Emergency Stop - No Loopback (L),</p> <p>Protective Stop (L), Protective Stop - STO (L), Protective Stop - SS1 (L), Protective Stop - SS2 (L),</p> <p>Protective Stop (L) - Auto Reset & Resume (R), Interlock Reset (R), Reduced Speed Activation(L),</p> <p>3-Pos Enable Switch (H), Handguiding Enable Switch (H), Remote Control Enable (H),</p> <p>Safety Zone Dynamic Enable (H), Safety Zone Dynamic Enable (L), HGC End & Task Resume (R)</p>	<p>Emergency Stop (L), Emergency Stop - excl. No Loopback Input (L),</p> <p>Safe Torque Off (L), Safe Operating Stop (L), Abnormal (L), Normal Speed (L), Reduced Speed (L),</p> <p>Auto Mode (L), Manual Mode (L), Remote Control Mode (L), Standalone Zone (L), Collaborative Zone (L)</p> <p>High Priority Zone (L), Tool Orientation Limit Zone (L), Designated Zone (L)</p>

1.11 Safety Function Settings

	Classification	Safety Settings	Description
1	Basic/Universal Settings	World Coordinates Setting (p. 255)	A coordinate system representing the robot and workpiece can be set.
		Robot Limits Setting (p. 273)	The universal safety limit for joints and robot/TCP safety-rated monitoring functions can be set.
		Safety I/O Setting (p. 260)	Configurable digital I/O ports can be set as safety signal I/Os.
		Safety Stop Modes (p. 38)	The Stop Mode can be set when the Emergency Stop or Protective Stop is activated, or when the safety-rated monitoring function detects limit violation.

	Classification	Safety Settings	Description
		Nudge(p. 39)	Parameters related to the nudge function, which is capable of resetting Protective Stop or resuming auto operation of the robot can be set when specific conditional are met.
2	Tool and Robot Pose	Tool Weight Setting(p. 276)	The workpiece payload, which acts as the basis for control and safety functions, can be set.
		Tool Shape Setting(p. 254)	Robot tool shapes, which are used in space limit and self-collision prevention functions, can be set.
		Mount Setting(p. 278)	The robot installation pose can be set.
3	Space Limit	Space Limit Settings(p. 266)	The robot/TCP position limit function can be activated.
4	Zone	Collaborative Zone Settings(p. 267)	<p>It is the zone which can be set for collaborative work between robot and operator.</p> <ul style="list-style-type: none"> • Nudge or hand guiding control (HGC) functions can only be performed in the Collaborative Zone. • The task speed and joint speed can be decelerated automatically by setting deceleration rate, and the collision detection sensitivity, TCP force limit, TCP speed limit and Safety Stop Mode are overridden within the Zone. • Zones that are not set as the Collaborative Zone are treated as Standalone Zone of the robot.
		Crushing Prevention Zone Settings(p. 268)	<p>The robot work position and space around obstacles can be set to reduce the risk of limbs jamming between robots and obstacles.</p> <ul style="list-style-type: none"> • The robot TCP speed, collision sensitivity and safety stop mode are fixed at 200 mm/s or less, 100% and RS1 respectively, and the TCP force limit is overridden within the Zone. • It is treated as the Collaborative Zone.

	Classification	Safety Settings	Description
		Collision Sensitivity Reduction Zone Settings (p. 269)	<p>Just like the case where force must be applied via contact with the workpiece, collision detection and TCP force limit safety functions can be disabled (Muting) or can be used to ease off the limit.</p> <ul style="list-style-type: none"> • Unlike other zones, the collision detection sensitivity and TCP force limit can be set lower and higher than the universal limit respectively in the Collision Sensitivity Reduction Zone. • It is treated as a High Priority Zone.
		Tool Orientation Limit Zone Settings (p. 270)	<p>This can be used to reduce risks related to the direction of the workpiece or tool of the robot.</p> <ul style="list-style-type: none"> • If the tool center point (TCP) is positioned within the Zone, the TCP Orientation Limit safety function is activated.
		Custom Zone Settings (p. 271)	<p>Safety limits can be used differently by zones depending on the necessity of robot application.</p> <ul style="list-style-type: none"> • The selected safety limits is overridden within the Zone. • Properties of Collaborative Zone or High Priority Zone can be granted.

1.11.1 Robot Limits

In Robot Limits, universal safety limits of various safety functions related with robots can be set as Normal Mode and Reduced Mode.

If each robot parameter exceeds the configured safety limit, the robot activates Protective Stop. Robot limits can be set through **Workcell Manager > Robot Limits**.

Note

- Robot can be operated after removing the cause of Protective Stop and after deactivating Protective Stop by resetting.
- If the cause of the Protective Stop by safety functions cannot be removed, Safety Recovery Mode helps for restoration to Normal Operation because there is no Protective Stop by safety functions.

Caution

The safety limit is the condition in which the safety-rated monitoring function determines whether to activate robot stop or not. When stop is completed, the position of the robot and force applied externally may differ from the configured safety limit.

TCP/Robot

It limits various physical parameters related to the TCP/robot. This safety function can be used in power and force limit operation modes.

- **TCP Force:** It sets the force limit applied from the TCP of the robot end. It can be used for purposes of detecting unintended external forces.
- **Mechanical Power:** It sets the limit of the robot's mechanical power. Mechanical power is proportionate to the robot torque and speed.
- **TCP Speed:** It sets the speed limit of the TCP of the robot end. It can be used for speed and gap monitoring operation mode.
- **Momentum:** It sets the robot momentum limit. Momentum is proportionate to speed and weight, and the impact is the same as the physical amount.
- **Collision Sensitivity:** It sets the sensitivity of the collision detection function which determines whether to continue work or activate Protective Stop with the torque detected in each robot axis. If the sensitivity is 100%, it detects collisions by external forces very sensitively, and it seldom detects collision if the sensitivity is 1%.

Note

If the robot has stopped due to collision detection, the cause is one of the followings:

1. TCP force limit violation
2. Collision detection violation

Joint angle speed

It sets the maximum rotation speed of each axis. The limit can be set for each axis.

Note

- The joint angle speed is set to the maximum value as a default.
- In general, certain axis speed is not set differently among each other.

Joint angle

It sets the maximum operating angle of each axis. The limit can be set for each axis.

- All axes are capable of +/- 360 degree rotation, but the joint angle value is set to a limit in Normal Mode as a default.
- If the robot is installed on the ground, it is recommended to set the operation range of the axis No.2 to +/- 95 degrees to prevent the collision.

- If the robot is installed on a cylindrical pillar or if you deal with a workpiece close to the robot base, the joint angle limit can be modified to allow a wider operating range.



Note

Adding Workcell Items in the Zone allows a separate safety limit to be set for designated zones. Safety limits which are capable of overriding are designated depending on the zone type. For more information, refer to the following link.

- [Collaborative Zone Settings](#)(p. 267)
- [Crushing Prevention Zone Settings](#)(p. 268)
- [Collision Sensitivity Reduction Zone Settings](#)(p. 269)
- [Tool Orientation Limit Zone Settings](#)(p. 270)
- [Custom Zone Settings](#)(p. 271)

1.11.2 Safety I/O

This function inputs/outputs safety-related signals through a redundant terminal. If a signal that is different from the redundant safety input or output signal is detected, the system determines whether it is a short circuit or hardware defect and stops the robot with STO Stop Mode. To set the Safety I/O, go to the **Robot** Workcell and select **Robot > Safety I/O**.

Safety Input Setting

It can be used as a safety-rated output by assigning a safety signal to two consecutive ports of the configurable digital output (TBCO).

Signal Name	Description
Emergency Stop (L)	It is an interface to receive emergency stop signal from peripheral device, or connect additional emergency stop switches. <ul style="list-style-type: none"> • High: Normal operation • Low: It stops the robot according to the stop mode setting for Emergency Stop at the Safety Stop Mode.
Emergency Stop – No Loopback (L)	It is an interface to receive emergency stop signal from peripheral device, or connect additional emergency stop switches. This signal doesn't activate ' Emergency Stop – excl. No Loopback Input ' safety outp <ul style="list-style-type: none"> • High: Normal operation • Low: It stops the robot according to the stop mode setting for Emergency Stop at the Safety Stop Mode.

Signal Name	Description
Protective Stop (L)	<p>It can be linked with Safeguarding Devices such as safety mats, light curtains and laser scanners.</p> <ul style="list-style-type: none"> • High: Normal operation • Low: It stops the robot according to the stop mode setting for Protective Stop at the Safety Stop Mode.
Protective Stop – STO (L)	<ul style="list-style-type: none"> • High: Normal operation • Low: Immediately cuts the motor power and engages the brakes to force the robot to stop.
Protective Stop – SS1 (L)	<ul style="list-style-type: none"> • High: Normal operation • Low: Cuts off the motor power and engages the brakes after controlled stop.
Protective Stop – SS2 (L)	<ul style="list-style-type: none"> • High: Normal operation • Low: Position is maintained with power supplied to the motor and the brake disengaged after controlled stop.
Protective Stop(L) - Auto Reset & Resume (R)	<p>Unlike the other Protective Stop, Interrupted state can be reset and automatic operation can be resumed automatically by this signal. This enables automatic restart after Safety-rated Monitored Stop described in ISO TS 15066.</p> <ul style="list-style-type: none"> • Low: Follow Protective Stop – SS2. • Rising (Low to High): the task resumes automatically without manual reset or resume. <div style="border: 1px solid orange; padding: 10px; margin-top: 10px;"> <p> Warning Resuming automatic operation without manual intervention can be dangerous, DO conduct a comprehensive risk assessment to confirm that using this signal is safe</p> </div>
Interlock Reset (R)	<p>It is used to reset the Interrupted state by Protective Stop</p> <ul style="list-style-type: none"> • Rising(Low to High): Reset the restart interlock and permit return to normal standby state
Reduced Speed Activation (L)	<ul style="list-style-type: none"> • High: Operates the robot at the normal speed set in the task • Low: It operates the robot at a speed proportionately reduced from the speed set in the task. The reduction ratio can be adjusted using the Speed Reduction Ratio slide bar. If a signal is detected within a Collaborative Zone, the robot is operated at the smaller speed reduction ratio (slower) between the main speed reduction ratio and the Collaborative Zone speed reduction ratio.

Signal Name	Description
3 Pos Enable Switch (H)	<p>This is operation permission equipment that is used to connect a three-position enabling switch.</p> <ul style="list-style-type: none"> • High: Jog/Servo On are available in Manual Mode Play/Resume/Servo On are available in Auto Mode • Low: Jog/Servo On are prohibited in Manual Mode Play/Resume/Servo On are prohibited in Auto Mode
Handguiding Enable Switch (H)	<p>It is an operation permission signal used to connect a hand guide switch.</p> <ul style="list-style-type: none"> • High: Hand-guiding available • Low: Hand-guiding unavailable
HGC End & Resume (R)	<p>It is used to resume task program execution after operator's HandGuiding Control(HGC) in Auto Mode</p> <ul style="list-style-type: none"> • Rising(Low to High): Resumes task program after the handguiding control.
Safety Zone Dynamic Enable (H)	<p>It is available that activating/deactivating Space Limit and/or Zone dynamically.</p> <ul style="list-style-type: none"> • High: Activates the Space Limit or Zone set to be temporarily enabled or disabled by this signal • Low: Deactivates the Space Limit or Zone set to be temporarily enabled or disabled by this signal
Safety Zone Dynamic Enable (L)	<p>It is available that activating/deactivating Space Limit and/or Zone dynamically.</p> <ul style="list-style-type: none"> • High: Deactivates the Space Limit or Zone set to be temporarily enabled or disabled by this signal • Low: Activates the Space Limit or Zone set to be temporarily enabled or disabled by this signal
Remote Control Enable (L)	<p>Used to enable the Remote Control Mode.</p> <ul style="list-style-type: none"> • High: Remote Control Mode enabled. • Low: Remote Control Mode disabled.

Suspension of Protective Stop Signals

In robot teaching, recovery, and hand-guided control situations, the operator approaching to the robot may be intended task.

The **Suspension of Protective Stop Signals** function is provided for the protective device not to prevent these intended task.

Warning

Do conduct a comprehensive risk assessment to confirm that using this function is safe

The suspension of the protective stop related signals can be set per robot state group.

The protective stop related signal input is ignored when the robot is in the state included in the unchecked state group.

When the robot enters the automatic states, this function is terminated and the protective stop related signals are all activated.

The following are the protective stop related signals that can be suspended.

- **TBSFT - PR**
- **TBCI - Protective Stop (L)**
- **TBCI - Protective Stop - STO (L)**
- **TBCI - Protective Stop - SS1 (L)**
- **TBCI - Protective Stop - SS2 (L)**
- **TBCI - Protective Stop (L) - Auto Reset & Resume (R)**

The following are the state groups that the protective stop related signals can be suspended and the states they contain.

- **MANUAL Group- Manual Standby, Manual Jogging, Manual Handguiding**
- **RECOVERY Group- Recovery Standby, Recovery Jogging, Recovery Handguiding**
- **HGC Group- HGC Standby, HGC Running**

Safety Output Setting

It can be used as a safety-rated output by assigning a safety signal to two consecutive ports of the configurable digital output (TBCO).

Signal Name	Description
Emergency Stop (L)	<p>It is used to notify that emergency stop is required to peripheral devices, such situation as</p> <ul style="list-style-type: none"> - Emergency Stop Button is pushed on robot accessories (Teach pendant, Smart Pendant, Emergency Button Box) - Emergency Stop from the dedicated Safety Input - Emergency Stop (L) from the configurable Safety Input - Emergency Stop – No Loopback(L) from the configurable Safety Input. <ul style="list-style-type: none"> • High: Normal operation • Low: Emergency stop required

Signal Name	Description
Emergency Stop – excl. No Loopback Input (L)	<p>It is used to notify that emergency stop is required to peripheral devices, such situation as</p> <ul style="list-style-type: none"> - Emergency Stop Button is pushed on robot accessories (Teach pendant, Smart Pendant, Emergency Button Box) - Emergency Stop from the dedicated Safety Input - Emergency Stop (L) from the configurable Safety Input <p>The case of Emergency Stop – No Loopback(L) from the configurable Safety Input is EXCLUDED.</p> <p>Deadlocks can be avoided by not sending back the emergency stop signal to the peripheral device that originally sending emergency stop signal to robot.</p> <ul style="list-style-type: none"> • High: Normal operation • Low: Emergency stop required
Safe Torque Off (L)	<ul style="list-style-type: none"> • High: Robot is not in Servo Off, Emergency Stop state • Low: Robot is in Servo Off or Emergency Stop state
Safe Operating Stop (L)	<ul style="list-style-type: none"> • High: Robot is not in Standby state • Low: Robot is in Standby state, and standstill monitoring is activated.
Abnormal (L)	<ul style="list-style-type: none"> • High: Robot is not in Interrupted, Recovery, Auto Measure state • Low: Robot is in Interrupted, Recovery, or Auto Measure state
Normal Speed (L)	<ul style="list-style-type: none"> • High: Robot is operating at the reduced speed due to external Reduced Speed Activation safety input • Low: Robot is operating as normal speed
Reduced Speed (L)	<ul style="list-style-type: none"> • High: Robot is operating as normal speed • Low: Robot is operating at the reduced speed due to external Reduced Speed Activation safety input
Auto Mode (L)	<ul style="list-style-type: none"> • High: The robot is not in Auto Mode • Low: The robot is in Auto Mode
Manual Mode (L)	<ul style="list-style-type: none"> • High: The robot is not in Manual Mode • Low: The robot is in Manual Mode
Remote Control Mode (L)	<ul style="list-style-type: none"> • High: The robot is not in Remote Control Mode • Low: The robot is in Remote Control Mode
Standalone Zone (L)	<ul style="list-style-type: none"> • High: The robot's TCP is in a Collaborative Zone • Low: The robot's TCP is not in any Collaborative Zone

Signal Name	Description
Collaborative Zone (L)	<ul style="list-style-type: none"> • High: The robot's TCP is not in any Collaborative Zone • Low: The robot's TCP is in a Collaborative Zone
High Priority Zone (L)	<ul style="list-style-type: none"> • High: The robot's TCP is not in any Collision Sensitivity Reduction Zone and not in a High Priority Zone option checked Custom Zone • Low: The robot's TCP is in a Collision Sensitivity Reduction Zone or in a High Priority Zone option checked Custom Zone
Tool Orientation Limit Zone (L)	<ul style="list-style-type: none"> • High: The robot's TCP is not in any Tool Orientation Limit Zone • Low: The robot's TCP is in a Tool Orientation Limit Zone
Designated Zone (L)	<p>This is used to confirm if the TCP (Tool Center Point) is inside the user-defined Zone.</p> <p>The Designated Zone signal defined on the Safety Output setting UI can be selected from the Zone setting UI</p> <ul style="list-style-type: none"> • High: If the TCP is not inside any Zone linked with the Designated Zone safety output • Low: If the TCP is inside a Zone linked with the Designated Zone safety output

1.11.3 Safety Stop Modes

The safety-rated monitoring function can detect limit violations and set the Stop Mode used when stopping the robot.

- For more information about Stop Mode, refer to [Safety-rated Stop Subfunction](#)(p. 22).

To set the Safety Stop Modes, select **Workcell Manager > Robot > Safety Stop Modes**. For more information about each item, refer to [Safety-rated Monitoring Function](#)(p. 25).

	Safety Stop Mode	Description
1	Emergency Stop	It sets the Stop Mode when the Emergency Stop button of the teach pendant or the additionally installed external device is activated. (Only STO or SS1 can be selected.)
2	Protective Stop	It sets the Stop Mode when the externally connected protective equipment is activated.
3	Joint Angle Limit Violation	It sets the Stop Mode when the angle of each joint exceeds the set limit range.
4	Joint Speed Limit Violation	It sets the Stop Mode when the angle joint speed of each joint exceeds the set limit range.

	Safety Stop Mode	Description
5	Collision Detection	It sets the Stop Mode when the external force applied to the axis exceeds the set limit range. Stop modes for Collaborative Zone and Standalone Zone can be set individually. In addition to STO , SS1 and SS2 , RS1 can be set as the stop mode.
6	TCP/Robot Position Limit Violation	It sets the Stop Mode activated when the tool center point (TCP) and robot position violate the Position Limit of the Robot set in the Workcell Manager . It also determines whether the TCP is within the Safety Zone (Collaborative Zone , Crushing Prevention Zone , Collision Sensitivity Reduction Zone , Tool Orientation Limit Zone , or Custom Zone).
7	TCP Orientation Limit Violation	It sets the Stop Mode when the tool center point (TCP) orientation within the TCP Orientation Limit Zone exceeds the angle limit range set by the Robot through the Workcell Manager .
8	TCP Speed Limit Violation	It sets the Stop Mode when the speed of the tool center point (TCP) exceeds the set limit range.
9	TCP Force Limit Violation	It sets the Stop Mode when the external force applied to the tool center point (TCP) exceeds the set limit range. Stop modes for Collaborative Zone and Standalone Zone can be set individually. In addition to STO , SS1 and SS2 , RS1 can be set as the Stop Mode.
10	Momentum Limit Violation	It sets the Stop Mode when the robot momentum exceeds the set limit.
11	Mechanical Power Limit Violation	It sets the Stop Mode when the mechanical power of the robot exceeds the set limit.

1.11.4 Nudge

If the robot is stopped by Safety Stop Mode **SS2** or **RS1** within a Collaborative Zone, the Interrupted state can be reset and task can be resumed with Nudge input. Nudge option can be enabled on user defined sections.

To set Nudge, select the **Nudge** item from the **Robot** Workcell. With nudge input, the force to be recognized (nudge force) and the standby time from nudge recognition and until the resuming the work (delay time) can be entered additionally.

The configurable range of Input force for Nudge is between **10.00 ~ 50.00N** for the **M series** and **15.00 ~ 50.00N** for the **H series (P series)**.

Input Force	<input type="text" value="10.00"/> N
Delay Time	<input type="text" value="2.0"/> sec

⚠ Warning

- Nudge must only be used only if approved through comprehensive risk assessment.

1.11.5 Space Limit

In addition to the robot's joint angle limit of [Robot Limits\(p. 31\)](#), the robot can restrict the operating space on orthogonal coordinates. If the robot or TCP violates the space limit in automatic or manual mode, it stops according to the **Safety Stop Mode** setting.

When the robot or TCP reaches the boundary of the **Space Limit** during direct teaching using hand guiding, a repelling force can be felt.

By selecting the **Inspection Point**, it is possible to select whether the **Space Limit** will target the entire robot body or only the TCP.

By selecting the **Valid Space**, it is possible to select whether the Inspection Point will not violate or not exceed a designated space.

It is possible to easily designate an expanded volume from designated coordinates using **Zone Margin**.

Selecting **Dynamic Zone Enable** will enable/disable the zone according to the input signal from the I/O port. If the input is not enabled, the corresponding **Space Limit** will become disabled, and the robot operates as if the corresponding **Space Limit** is not present.

1.11.6 Zone

Depending on the application, it may be necessary to set a safety limit different from the global safety limit designated by "[Robot Limits Setting\(p. 273\)](#)" in certain spaces. It is possible to set a separate safety limit only in the designated section using the section setting function. Overridable safety limits are designated depending on the section type.

- [Collaborative Zone Settings\(p. 267\)](#)
- [Crushing Prevention Zone Settings\(p. 268\)](#)
- [Collision Sensitivity Reduction Zone Settings\(p. 269\)](#)
- [Tool Orientation Limit Zone Settings\(p. 270\)](#)
- [Custom Zone Settings\(p. 271\)](#)

By selecting the **Valid Space**, it is possible to select whether the **Inspection Point** cannot enter the designated space or cannot leave the space.

With the **Zone Margin**, the expanded volume from the designated volume with specified points can be easily configured.

Safety Limits that is overridden in **Zone** has the priority below.

- Safety limit overridden inside **Zone** has priority over the global **Safety Limits**
- Safety limit overridden inside **High Priority Zone** has priority over safety limit overridden inside **Zone**.
- If there are several safety limits for one type of safety function at certain TCP position because of overlapped **Zones**, the most restricted safety limit has the priority.
- If there are several safety limits for one type of safety function at certain TCP position because of overlapped **High Priority Zones**, the LEAST restricted safety limit has the priority.

Warning

High Priority Zones have priority over the other Zones and global **Robot Limits** setting. And If multiple **High Priority Zones** are overlapped, the safety function uses the **LEAST** restricted safety limit. For these reasons, the size of **High Priority Zone** should be specified as small as possible for safety

If **Dynamic Zone Enable** is selected, that **Zone** is activated/deactivated according to the designated **Safety I/O** Input signal. If the Input is active, then the corresponding **Zone** is activated. If the Input is not active, then the corresponding **Zone** is deactivated, and Robot operates as same as without that **Zone**.

1.12 Other Safety Measures

The system offers Safety Recovery Mode and Backdrive Mode for user safety and robot recovery.

- **Safety Recovery Mode:** If there is an error with a continuing safety violation or if a robot is to be packed, the user can use Safety Recovery Mode to configure the position and angle of the robot. For more information about Safety Recovery Mode, refer to [Safety Recovery Mode\(p. 305\)](#).
- **Backdrive Mode:** The system controls the robot joint with only the brake and without power driving the motor. This function is used when the robot cannot return to normal with Safety Recovery mode or Hand-guiding. With Backdrive mode, the user can engage or disengage the brake of each joint. For more information about Backdrive Mode, refer to [Backdrive Mode\(p. 307\)](#).

1.13 Validity and Responsibility

This manual does not provide information about the design, installation and operation methods of robot applications integrated with other system. In addition, this manual does not provide information that may influence the safety of the integrated system.

The system administrator must install the robot in a way that observes various safety requirements according to the related national standards and regulations. In addition, the staff in charge of integrating and managing the robot in a system must ensure that all related national safety legislation and regulations are observed. The

entity or user of the final system in which the robot is integrated has the following responsibilities, and such responsibilities are not limited to the items listed below.

- Risk assessment of the system with the robot integrated
- Installation and removal of safety devices according to the outcome of the risk assessment performed
- Confirmation of whether the system is properly designed, set up and installed
- Establishment of system operation and instructions
- Management of suitable safety settings in the software
- Prevention of users modifying safety devices
- Validity check of design and installation of integrated system
- Indication of contact information or important notifications related to use and safety
- Provision of technical documents including various manuals
- Provision of information on standards and legislation applied: <http://www.doosanrobotics.com/>



Compliance with the safety requirements in this manual does not mean all risks can be prevented.

1.14 Disclaimer

Doosan Robotics continues to upgrade product reliability and performance, and Doosan Robotics has the right to upgrade the product without notification. Doosan Robotics endeavors to ensure that all contents in this manual are accurate. However, it does not assume responsibility for errors or missing information.

1.15 Declaration and Certification

1.15.1 Europe Declaration of Incorporation (Original)

DECLARATION OF INCORPORATION	
according to EC Machinery Directive 2006/42/EC Annex II Part 1 Section B	
We,	
Doosan Robotics Inc.	
79, Saneop-ro 156beon-gil, Gwonseon-gu, Suwon-si, Gyeonggi-do, 16648, Republic of Korea	
declare under our sole responsibility that the following product:	
Product :	Industrial Robot (Manipulator & Controller)
Model :	Manipulator : M0609, M1509, M1013, M0617 Controller : CS-01
is in conformity with the following standard(s) or other normative document(s)	
Standard	Description
EN ISO 12100:20100	Safety of machinery General principles for design Risk assessment and risk reduction
EN ISO 10218-1	Robots and robotic devices - Safety requirements for industrial robots Part 1: Robots
EN 60204-1:2006/A1:2009	Safety of machinery Electrical equipment of machines Part 1: General requirements
The product as the partly completed machinery must not be put into service until the final machinery into which it is to be incorporated has been declared in conformity with the provisions of the Directive 2006/42/EC, as amended by Directive 2009/127/EC, and with the regulations transposing it into national law.	
Relevant technical documentations are compiled in accordance with Annex VII, part B of the Directive, and available in electronic form to national authorities upon legitimate request.	
Additionally the product declares in conformity with the following directives, according to which the product is CE marked:	
2014/35/EU	Low Voltage Directive (LVD)
2014/30/EU	Electromagnetic Compatibility Directive (EMC)
Suwon, 15 th October, 2018 R&D Center	
 Junhyun Jang Chief Technical Officer	
	

1.15.2 Europe Machinery Directive Attestation of Conformity

ZERTIFIKAT ◆ CERTIFICATE ◆ 認證證書 ◆ СЕРТИФИКАТ ◆ CERTIFICADO ◆ CERTIFICAT



Attestation

No. M7 004249 0034 Rev. 00

Holder of Certificate: **Doosan Robotics Inc**
79, Saneop-ro 156beon-gil, Gwonseon-gu
Suwon-si, Gyeonggi-do 16648
REPUBLIC OF KOREA

Product: **Industrial Robot
(Manipulator & Controller)**

This Attestation is issued on a voluntary basis according to Council Directive 2006/42/EC relating to machinery. It confirms that the listed equipment (partly completed machine) complies with the requirements set in article 13 of the directive. It refers only to the sample submitted to TÜV SÜD Product Service GmbH for testing and certification. For details see: www.tuvsud.com/ps-cert

Test report no.: MAEB01052621

Date, 2021-01-20

(Ro-Hyun Park)

Page 1 of 2

Partly completed machines are designated to be assembled in a machine, which complies with the requirements set in the Machinery Directive 2006/42/EC and for which a Declaration of Conformity according to Annex II A of the Machinery Directive 2006/42/EC needs to be drawn up.

TÜV SÜD Product Service GmbH • Certification Body • Riderstraße 65 • 80339 Munich • Germany

TUV®



Attestation

No. M7 004249 0034 Rev. 00

Model(s): Manipulator : M0609, M0617, M1013, M1509, H2017, H2515

Controller : CS-01, CS-01P, CS-02

Parameters:	Manipulator:	M0609	M0617	M1013	M1509
	Payload:	6 kg	6 kg	10 kg	15 kg
	Degrees of freedom:	6 Axis	6 Axis	6 Axis	6 Axis
	Weight:	27 kg	34 kg	33 kg	32 kg
			H2017	H2515	
			20 kg	25 kg	
			6 Axis	6 Axis	
			74 kg	72 kg	
	Controller:	CS-01	CS-01P	CS-02	
	Rated Input voltage:	100-240 V a.c., 1 Phase	100-240 V a.c., 1 Phase	22-60 V d.c.	
	Rated frequency:	50/60 Hz	50/60 Hz	N/A	
	Weight:	13 kg	17 kg	12 kg	

Tested according to: EN ISO 10218-1:2011
EN ISO 12100:2010
EN 60204-1:2006/A1:2009

Page 2 of 2

Partly completed machines are designated to be assembled in a machine, which complies with the requirements set in the Machinery Directive 2006/42/EC and for which a Declaration of Conformity according to Annex II A of the Machinery Directive 2006/42/EC needs to be drawn up.

TÜV SÜD Product Service GmbH • Certification Body • Ridlerstraße 65 • 80339 Munich • Germany

TUV®

1.15.3 Europe EMC Directive Attestation of Conformity

ZERTIFIKAT ◆ CERTIFICATE ◆ 認證書 ◆ CERTIFICADO ◆ CERTIFICAT



Attestation of Conformity

No. E8A 004249 0033 Rev. 00

Holder of Certificate: **Doosan Robotics Inc**
79, Saneop-ro 156beon-gil, Gwonseon-gu
Suwon-si, Gyeonggi-do 16648
REPUBLIC OF KOREA

Name of Object: **Industrial Robot
(Manipulator & Controller)**

Model(s): **Manipulator: M0609, M0617, M1013, M1509, H2017, H2515
Controller: CS-01, CS-01P, CS-02**

Description of Object:

Rated input voltage:	CS-01 100-240 V a.c., 1 Phase
Rated input frequency:	50/60 Hz
Rated input voltage:	CS-01P 100-240 V a.c., 1 Phase
Rated input frequency:	50/60 Hz
Rated input voltage:	CS-02 22-60 V d.c.

Tested according to: EN 61000-6-4:2007/A1:2011
EN 61000-6-2:2005
EN 61000-3-2:2014
EN 61000-3-3:2013

This Attestation of Conformity is issued on a voluntary basis according to the Directive 2014/30/EU relating to electromagnetic compatibility. It confirms that the listed apparatus complies with all essential requirements of the directive and is based on the technical specifications applicable at the time of issuance. It refers only to the particular sample submitted for testing and certification. For details see: www.tuvsud.com/ps-cert

Test report no.: CPSC01387620

Date, 2020-08-26

(Byung-Soo Kang)

Page 1 of 1

After preparation of the necessary technical documentation as well as the EU Declaration of conformity the required CE marking can be affixed on the product. That Declaration of conformity is issued under the sole responsibility of the manufacturer. Other relevant EU-directives have to be observed.

TÜV SÜD Product Service GmbH • Certification Body • Ridlerstraße 65 • 80339 Munich • Germany

TUV®

1.15.4 U.S. NRTL Certification (U.S., CANADA)

ZERTIFIKAT ◆ CERTIFICATE ◆ 認 証 証 書 ◆ CERTIFICADO ◆ CERTIFICAT



CERTIFICATE

No. U8 004249 0032 Rev. 00

Holder of Certificate: **Doosan Robotics Inc**
79, Saneop-ro 156beon-gil, Gwonseon-gu
Suwon-si, Gyeonggi-do 16648
REPUBLIC OF KOREA

Certification Mark:



Product: **Industrial Robot
(Manipulator & Controller)**

This product was voluntarily tested to the relevant safety requirements referenced on this certificate. It can be marked with the certification mark above. The mark must not be altered in any way. This product certification system operated by TÜV SÜD America Inc. most closely resembles system 3 as defined in ISO/IEC 17067. Certification is based on the TÜV SÜD "Testing and Certification Regulations". TÜV SÜD America Inc. is an OSHA recognized NRTL and a Standards Council of Canada accredited Certification body.

Test report no.: MAEA07220420

Date, 2020-07-30

(Ro-Hyun Park)

Page 1 of 2
TÜV SÜD America Inc. • 10 Centennial Drive • Peabody • MA 01960 • USA

TÜV®



CERTIFICATE

No. U8 004249 0032 Rev. 00

Model(s): Manipulator : M0609, M0617, M1013, M1509, H2017, H2515
Controller : CS-01, CS-01P, CS-02

Tested according to: UL 1740:2007/R:2015-01
CAN/CSA-Z434:2014/R:2019

Production Facility(ies): 004249

Parameters:	Manipulator:	M0609	M0617	M1013	M1509
	Payload:	6 kg	6 kg	10 kg	15 kg
	Degrees of freedom:	6 Axis	6 Axis	6 Axis	6 Axis
	Weight:	27 kg	34 kg	33 kg	32 kg
		H2017	H2515		
		20 kg	25 kg		
		6 Axis	6 Axis		
		74 kg	72 kg		
	Controller:	CS-01	CS-01P	CS-02	
	Rated input voltage:	100-240 V a.c., 1 Phase	100-240 V a.c., 1 Phase	22-60 V d.c.	
	Rated frequency:	50/60 Hz	50/60 Hz	N/A	
	Weight:	13 kg	17 kg	12 kg	

Additionally tested to: ANSI/NFPA 79:2015

1.15.5 Functional Safety Certification

ZERTIFIKAT ◆ CERTIFICATE ◆ 認證書 ◆ CERTIFICADO ◆ CERTIFICAT



CERTIFICATE

No. Z10 004249 0013 Rev. 01

Holder of Certificate: Doosan Robotics Inc
79, Saneop-ro 156beon-gil, Gwonseon-gu
Suwon-si, Gyeonggi-do 16648
REPUBLIC OF KOREA

Certification Mark:



Product: Robot Safety Unit

The product was tested on a voluntary basis and complies with the essential requirements.
The certification mark shown above can be affixed on the product. It is not permitted to alter the certification mark in any way. In addition the certification holder must not transfer the certificate to third parties. This certificate is valid until the listed date, unless it is cancelled earlier. All applicable requirements of the testing and certification regulations of TÜV SÜD Group have to be complied.
For details see: www.tuvsud.com/ps-cert

Test report no.: DS93146T

Valid until: 2026-11-25

Date, 2021-11-29

(Guido Neumann)



CERTIFICATE

No. Z10 004249 0013 Rev. 01

Parameters: **Safety functions:**
 STO, SBC, Emergency Stop: **SIL3, PL e CAT4**
 SS1, SS2, SOS, SLP, SLS, SLT, Protective Stop,
 TCP/Robot Position Limit, TCP Orientation Limit, TCP Speed Limit,
 TCP Force Limit, Robot Momentum Limit, Robot Power Limit,
 Collision Detection, Safety I/O, Nudge, Reflex Stop: **SIL2, PL d CAT3**

Safety I/O input	Safety I/O output
Emergency Stop, Emergency Stop – No Loopback, Protective Stop, Protective Stop – STO, Protective Stop – SS1, Protective Stop – SS2, Protective Stop – Auto Reset & Resume, Interlock Reset, Reduced Speed Activation, 3-Pos Enable Switch, Handguiding Enable Switch, Remote Control Enable, Safety Zone Dynamic Enable, HGC End & Task Resume	Emergency Stop, Emergency Stop - excl. No Loopback Input, Safe Torque Off, Safe Operating Stop, Abnormal, Normal Speed, Reduced Speed, Auto Mode, Manual Mode, Remote Control Mode, Standalone Zone, Collaborative Zone, High Priority Zone, Tool Orientation Limit Zone, Designated Zone

Tested according to:
 IEC 61508-1:2010
 IEC 61508-2:2010
 IEC 61508-3:2010
 IEC 61800-5-1:2007
 IEC 61800-5-1:2007/AMD1:2016
 IEC 61800-5-2:2016
 ISO 13849-1:2015
 IEC 62061:2021
 ISO 10218-1:2011
 ISO TS 15066:2016
 IEC 61000-6-7:2014
 IEC 61326-3-1:2017

Model(s): **Safety Controller for Multi-powered Robot**

1.15.6 Voluntary Safety Confirmation Declaration (KCs)



자율안전확인 신고증명서

신청인	사업장명	두산로보틱스주식회사	사업장관리번호	257-88-001280
	사업자등록번호	257-88-00128	대표자 성명	이병서
	소재지	(16648) 경기도 수원시 권선구 산업로156번길 79		
자율안전인증대상 기계·기구명		산업용로봇		
형식(규격)	M0609	용량(등급)	6 axis	
자율안전확인번호	17-AB1EQ-01516			
제조자	두산로보틱스주식회사			
소재지	(16648) 경기도 수원시 권선구 산업로156번길 79			

「산업안전보건법」 제35조제1항 및 같은 법 시행규칙 제61조제3항에 따라
자율안전확인 신고증명서를 발급합니다.

2017년 12월 05일

한국산업안전보건공단 서울지역본부장





자율안전확인 신고증명서

신청인	사업장명	두산로보틱스 주식회사	사업장관리번호	257-88-001280
	사업자등록번호	257-88-00128	대표자 성명	이병서
	소재지	(16648) 경기도 수원시 권선구 산업로156번길 79		
자율안전인증대상 기계·기구명		산업용로봇		
형식(규격)	M1509	용량(등급)	6 axis	
자율안전확인번호	18-AB1EQ-00589			
제조사	두산로보틱스주식회사			
소재지	(16648) 경기도 수원시 권선구 산업로156번길 79			

「산업안전보건법」 제35조제1항 및 같은 법 시행규칙 제61조제3항에 따라
자율안전확인 신고증명서를 발급합니다.

2018년 02월 23일

한국산업안전보건공단 서울지역본부장





자율안전확인 신고증명서

신청인	사업장명	두산로보틱스주식회사	사업장관리번호	257-88-001280
	사업자등록번호	257-88-00128	대표자 성명	이병서
	소재지	(16648) 경기도 수원시 권선구 산업로156번길 79		
자율안전인증대상 기계·기구명		산업용로봇		
형식(규격)	M1013	용량(등급)	6 axis	
자율안전확인번호	17-AB1EQ-01514			
제조사	두산로보틱스주식회사			
소재지	(16648) 경기도 수원시 권선구 산업로156번길 79			

「산업안전보건법」 제35조제1항 및 같은 법 시행규칙 제61조제3항에 따라
자율안전확인 신고증명서를 발급합니다.

2017년 12월 05일

한국산업안전보건공단 서울지역본부장





자율안전확인 신고증명서

신청인	사업장명	두산로보틱스주식회사	사업장관리번호	257-88-001280
	사업자등록번호	257-88-00128	대표자 성명	이병서
	소재지	(16648) 경기도 수원시 권선구 산업로156번길 79		
자율안전인증대상 기계·기구명		산업용로봇		
형식(규격)	M0617	용량(등급)	6 axis	
자율안전확인번호	17-AB1EQ-01515			
제조사	두산로보틱스주식회사			
소재지	(16648) 경기도 수원시 권선구 산업로156번길 79			

「산업안전보건법」 제35조제1항 및 같은 법 시행규칙 제61조제3항에 따라
자율안전확인 신고증명서를 발급합니다.

2017년 12월 05일



한국산업안전보건공단 서울지역본부장

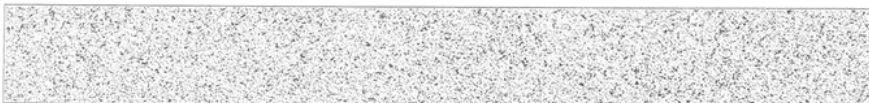



자율안전확인 신고증명서

신청인	사업장명	두산로보틱스(주)	사업장관리번호	257-88-001280
	사업자등록번호	257-88-00128	대표자 성명	곽상철
	소재지	(16648) 경기도 수원시 권선구 산업로156번길 79(고색동)		
자율안전인증대상 기계·기구명		산업용로봇		
형식(규격)	H2017	용량(등급)	6 axis	
자율안전확인번호		20-AE1EQ-02737		
제조사		두산로보틱스(주)		
소재지		(16648) 경기도 수원시 권선구 산업로156번길 79(고색동)		

「산업안전보건법」 제89조제1항 및 같은 법 시행규칙 제120조제3항에 따라
자율안전확인 신고증명서를 발급합니다.

2020년 08월 13일

한국산업안전보건공단 인천광역시본부장

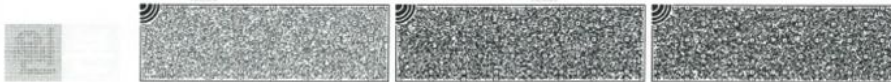



자율안전확인 신고증명서

신청인	사업장명	두산로보틱스(주)	사업장관리번호	257-88-001280
	사업자등록번호	257-88-00128	대표자 성명	곽상철
	소재지	(16648) 경기도 수원시 권선구 산업로156번길 79(고색동)		
자율안전인증대상 기계·기구명		산업용로봇		
형식(규격)	H2515	용량(등급)	6 axis	
자율안전확인번호		20-AE1EQ-02738		
제조자	두산로보틱스(주)			
소재지	(16648) 경기도 수원시 권선구 산업로156번길 79(고색동)			

「산업안전보건법」 제89조제1항 및 같은 법 시행규칙 제120조제3항에 따라
자율안전확인 신고증명서를 발급합니다.

2020년 08월 13일

한국산업안전보건공단 인천광역시본부장





자율안전확인 신고증명서

신청인	사업장명	두산로보틱스(주)	사업장관리번호	257-88-001280
	사업자등록번호	257-88-00128	대표자 성명	이병서
	소재지	(16648) 경기도 수원시 권선구 산업로156번길 79(고색동)		
자율안전인증대상 기계·기구명		산업용로봇		
형식(규격)	CS-02	용량(등급)	6 axis	
자율안전확인번호	20-AE1EQ-00484			
제조사	두산로보틱스(주)			
소재지	(16648) 경기도 수원시 권선구 산업로156번길 79(고색동)			

「산업안전보건법」 제89조제1항 및 같은 법 시행규칙 제120조제3항에 따라
자율안전확인 신고증명서를 발급합니다.

2020년 02월 03일

한국산업안전보건공단 이사장



1.16 Stop Distance and Stop Time

1.16.1 Measurement Methods and Conditions

- Stop distance is the angle traveled from the moment a stop signal is generated to the moment all manipulator stop operation.
- Stop time is the time from the moment a stop signal is generated to the moment all manipulator stop operation.
- Stop distance and stop time data are provided for Joint 1, Joint 2 and Joint 3, which have large travel distances.
- The movement of an overlapping axis can cause a longer stop distance.
- Stop distance and stop time data are defined according to KS B ISO 10218-1:2011 [Declaration and Certification](#)(p. 43).

Stop Category

	Stop Category	Description
1	Stop Category 0	The stop distance and stop time of Joint 1 (Base), Joint 2 (Shoulder) and Joint 3 (Elbow) are measured at maximum speed, stretch level and load. The axes of Joint 2 and Joint 3 are parallel to each other, so an impact caused by forced stop on one part may cause a slip on the other side. The angle deviation is also measured.
2	Stop Category 1	The stop distance and stop time of Joint 1 (Base) and Joint 2 (Shoulder) are measured at 33%, 66% and 100% of the maximum speed, stretch level and load, respectively. The stop distance and stop time of Joint 3 (elbow) is measured at 33%, 66% and 100% of maximum speed and load. The stretch level during Joint 3 measurement is locked at maximum because of the lower arm length and completely flat wrist.

Measurement Poses and Conditions

Joint 1 measurement is performed with the rotating axis perpendicular to the ground and during horizontal movement.











Joint 2 and Joint 3 measurements are performed with the rotating axis parallel to the ground and when the robot is stopped in a downward movement vertical to the ground.

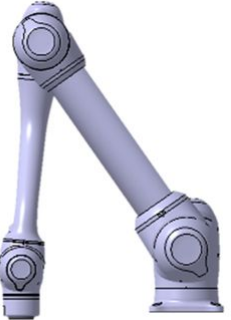

Note

The measurements are the result of the worst case. Measurement may vary according to circumstances

The pose for 33%, 66%, and 100% of extension

	Joint 1	Joint 2	Joint 3
100% extension Stop category 0			
33% extension Stop category 1			-
66% extension Stop category 1			-
100% extension Stop category 1			

The pose when the stop is initiated and the measured angle (θ_d)

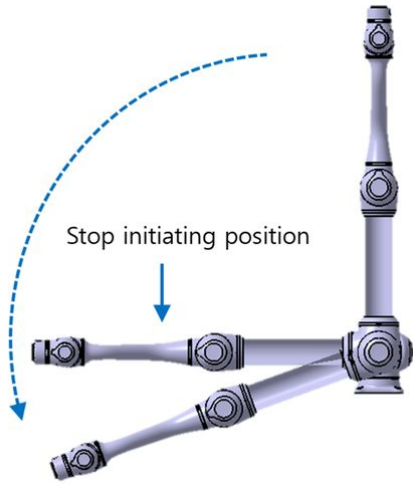
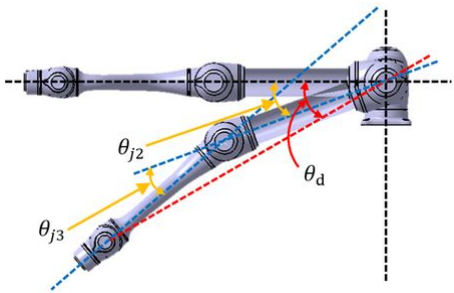
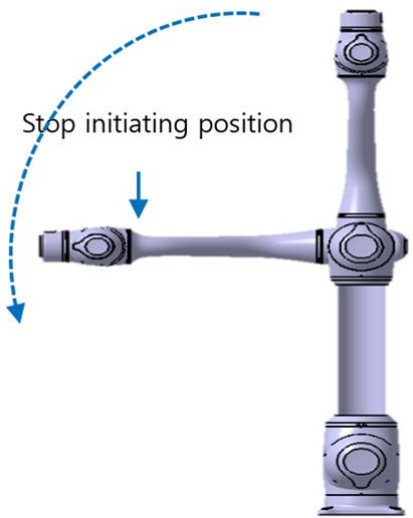
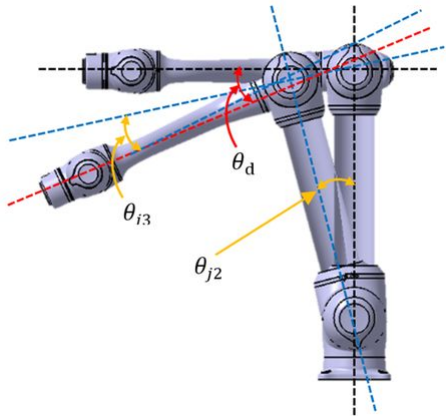
	Pose when the stop is initiated	Measured Angle
Joint1	<p>Stop initiating position</p> 	<p>No slip, $\theta_d = \theta_{j1}$</p>
Joint2	<p>Stop initiating position</p> 	
Joint3	<p>Stop initiating position</p> 	

1.16.2 M1013 Stop Category

M1013 Stop Category 0

Joint 1

Extension=100%, Speed=100%, Payload=100%

	Stopping distance (rad)	Stopping time (ms)
Joint 1	0.144	136

Joint 2

Extension=100%, Speed=100%, Payload=100%

	Stopping distance (rad)	Stopping time (ms)
Joint 2 (θ_{j2})	0.15	315
Joint 3 (θ_{j3})	0.346	
Distance (θ_d)	0.314	

Joint 3

Extension=100%, Speed=100%, Payload=100%

	Stopping distance (rad)	Stopping time (ms)
Joint 2 (θ_{j2})	0.161	225
Joint 3 (θ_{j3})	0.153	
Distance (θ_d)	0.279	

The joint 2 and joint 3 angles are refer to θ_{j2} , θ_{j3} , θ_d in [Measurement Poses and Conditions](#)(p. 58).

M1013 Stop Category 1

Stop Distance and Stop Time of Joint 1 (Base)

Stop Distance at 33% of Max. Load (deg)	Stop Time at 33% of Max. Load (s)

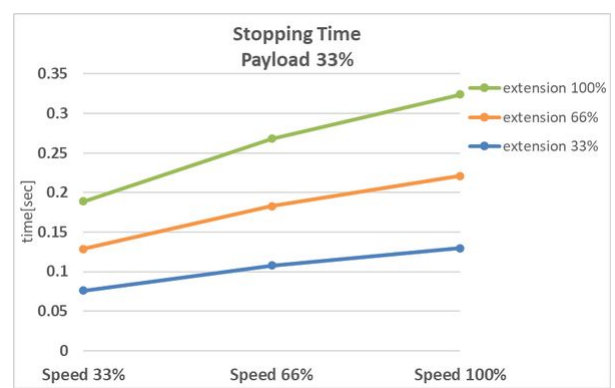
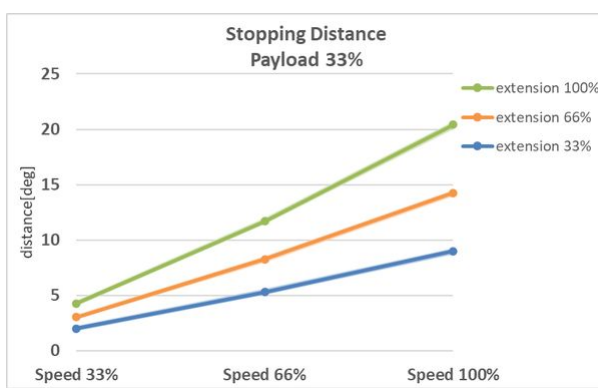

Stop Distance at 66% of Max. Load (deg)

Stop Time at 66% of Max. Load (s)

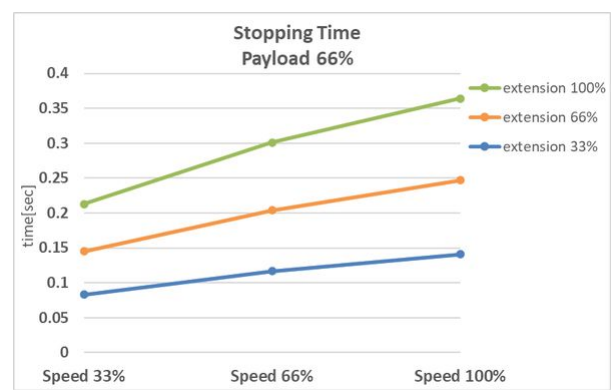

Stop Distance at Max. Load (deg)

Stop Time at Max. Load (s)

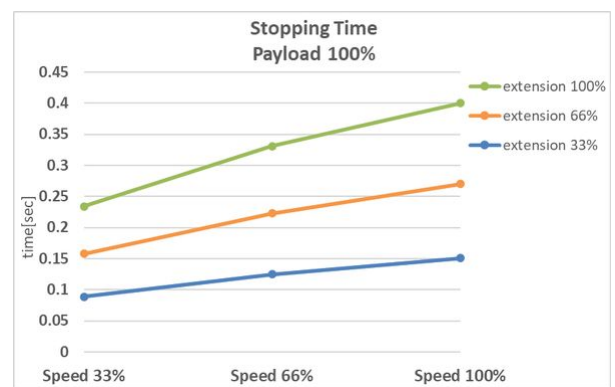

Stop Distance and Stop Time of Joint 2 (Shoulder)

Stop Distance at 33% of Max. Load (deg)

Stop Time at 33% of Max. Load (s)

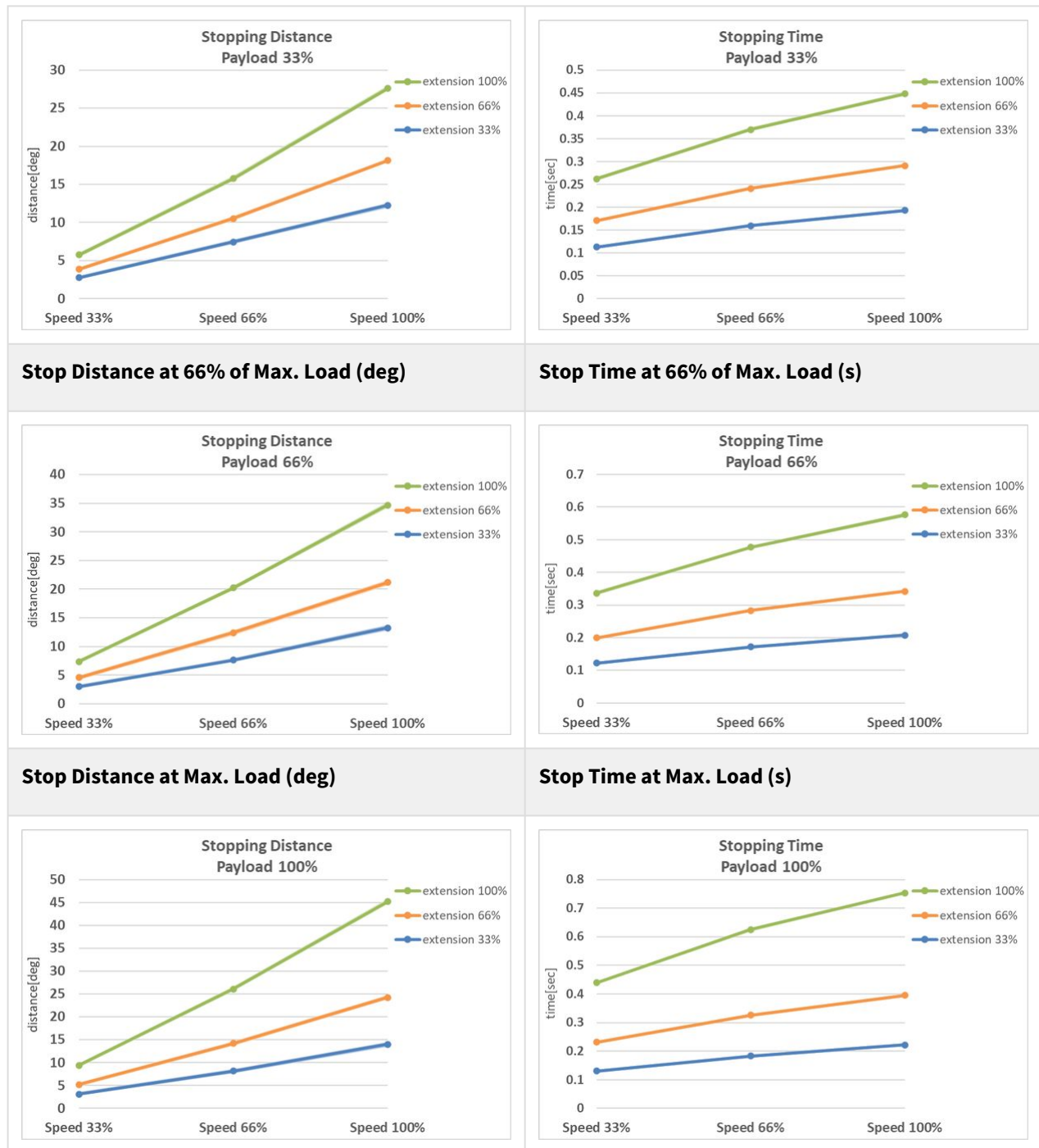

Stop Distance and Stop Time of Joint 3 (Elbow)



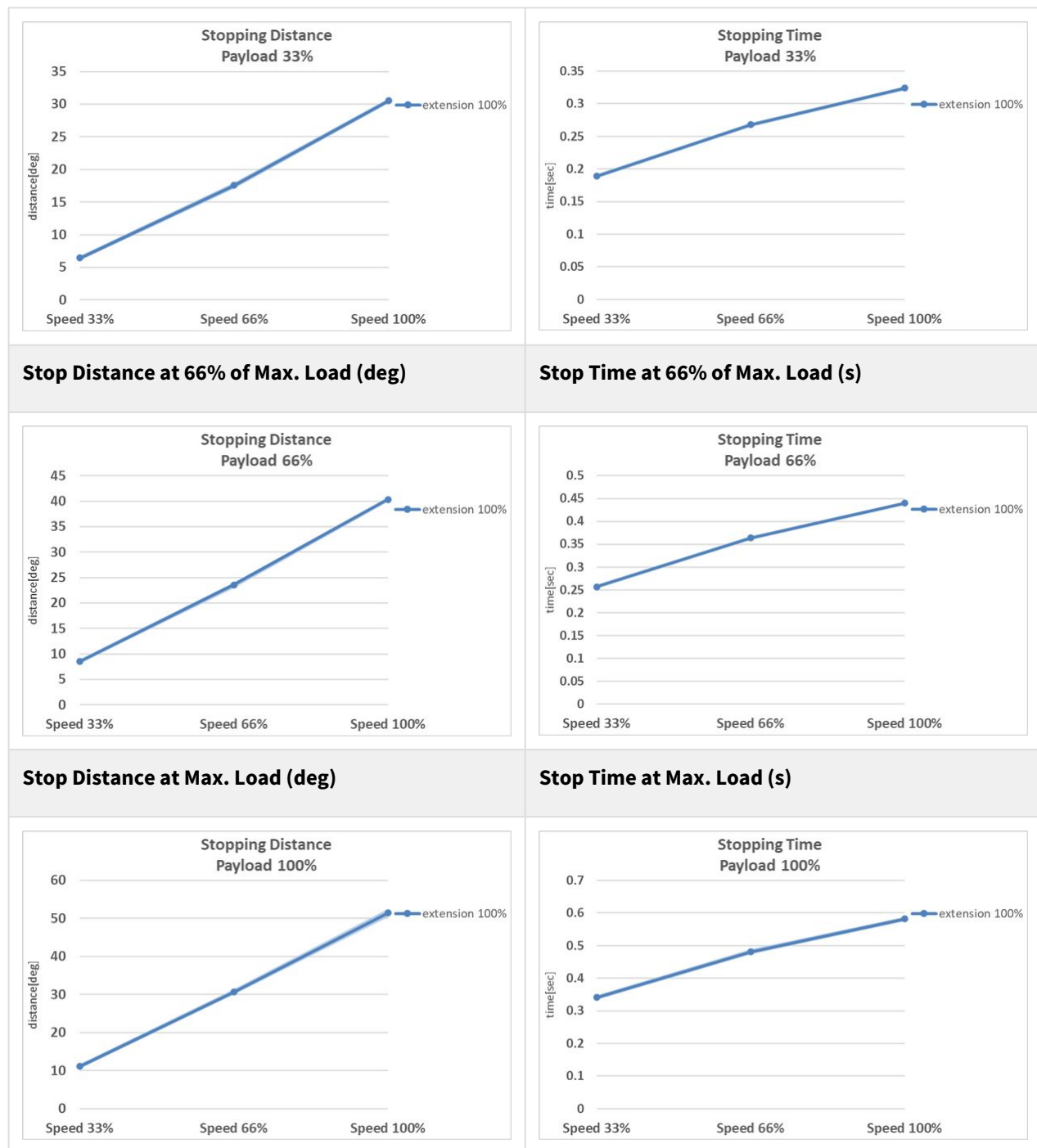

1.16.3 M0609 Stop Category

M0609 Stop Category 0

Joint 1

Extension=100%, Speed=100%, Payload=100%

	Stopping distance (rad)	Stopping time (ms)
Joint 1	0.133	92

Joint 2

Extension=100%, Speed=100%, Payload=100%

	Stopping distance (rad)	Stopping time (ms)
Joint 2 (θ_{j2})	0.171	305
Joint 3 (θ_{j3})	0.05	
Distance (θ_d)	0.195	

Joint 3

Extension=100%, Speed=100%, Payload=100%

	Stopping distance (rad)	Stopping time (ms)
Joint 2 (θ_{j2})	0.034	113
Joint 3 (θ_{j3})	0.122	
Distance (θ_d)	0.151	

The joint 2 and joint 3 angles are refer to θ_{j2} , θ_{j3} , θ_d in [Measurement Poses and Conditions](#)(p. 58).

M0609 Stop Category 1

Stop Distance and Stop Time of Joint 1 (Base)

Stop Distance at 33% of Max. Load (deg)	Stop Time at 33% of Max. Load (s)
---	-----------------------------------

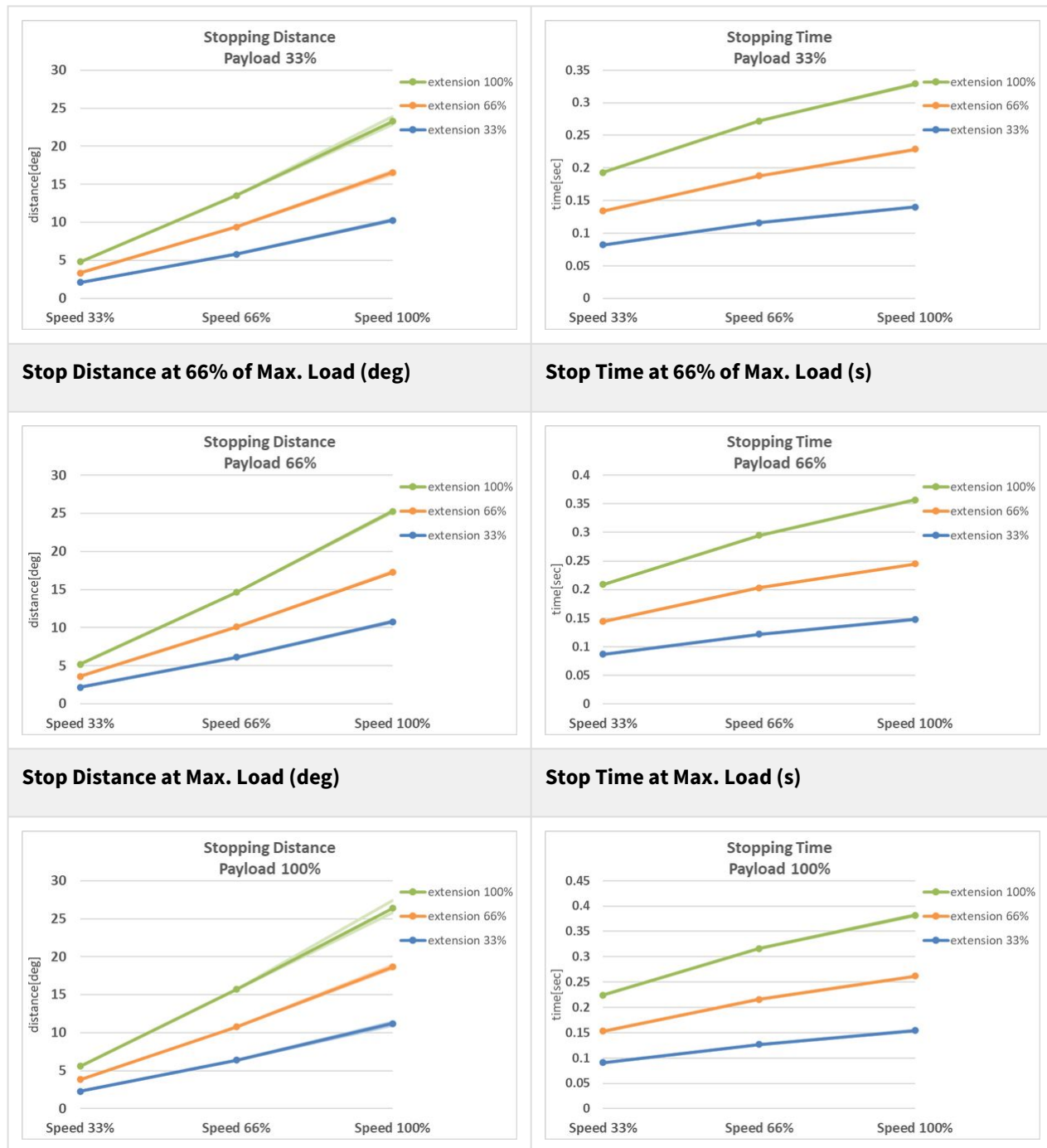

Stop Distance and Stop Time of Joint 2 (Shoulder)



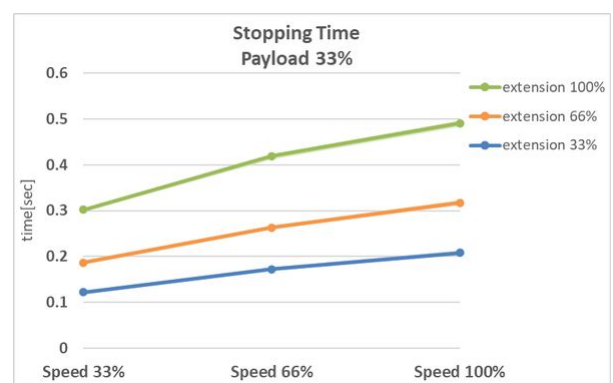
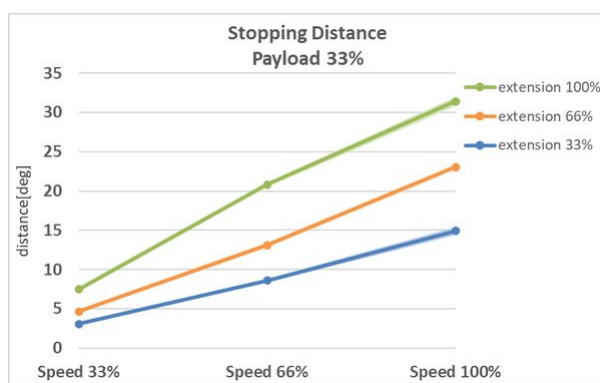

Stop Distance at 66% of Max. Load (deg)

Stop Time at 66% of Max. Load (s)

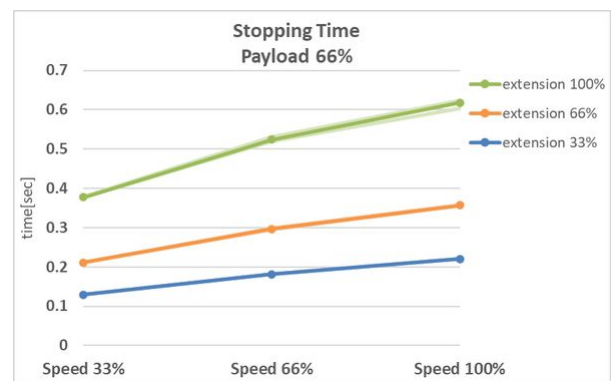
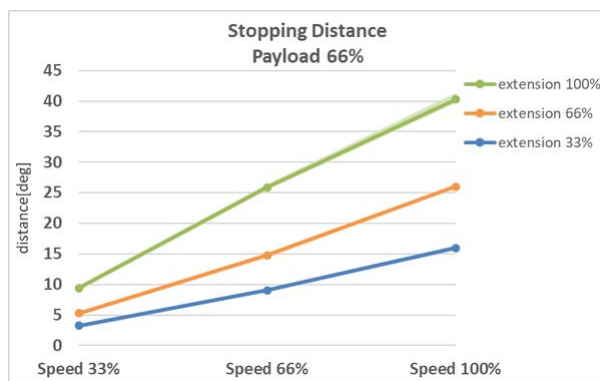

Stop Distance at Max. Load (deg)

Stop Time at Max. Load (s)

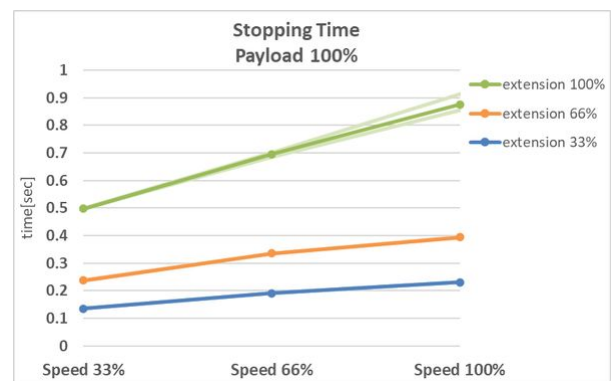
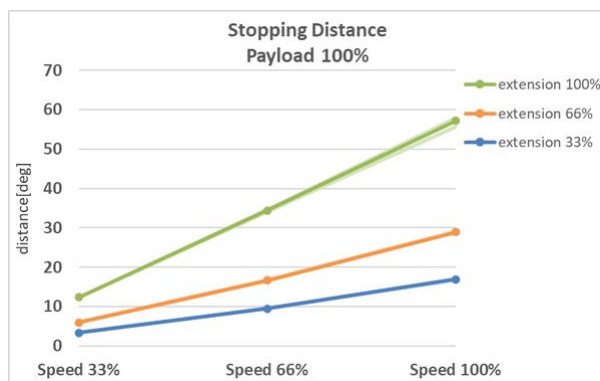

Stop Distance and Stop Time of Joint 3 (Elbow)

Stop Distance at 33% of Max. Load (deg)

Stop Time at 33% of Max. Load (s)

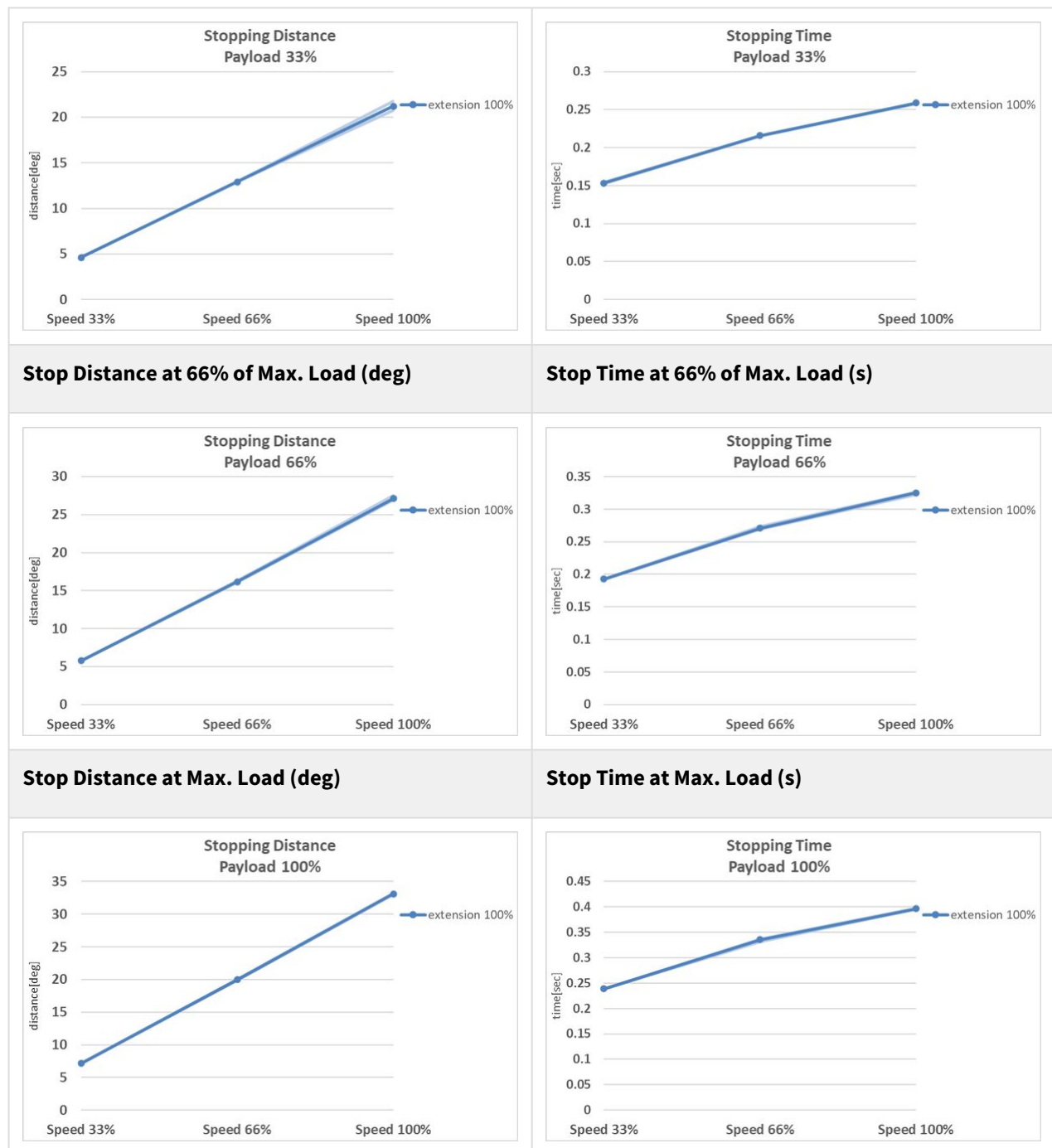

1.16.4 M0617 Stop Category

M0617 Stop Category 0

Joint 1

Extension=100%, Speed=100%, Payload=100%

	Stopping distance (rad)	Stopping time (ms)
Joint 1	0.095	89

Joint 2

Extension=100%, Speed=100%, Payload=100%

	Stopping distance (rad)	Stopping time (ms)
Joint 2 (θ_{j2})	0.104	326
Joint 3 (θ_{j3})	0.336	
Distance (θ_d)	0.26	

Joint 3

Extension=100%, Speed=100%, Payload=100%

	Stopping distance (rad)	Stopping time (ms)
Joint 2 (θ_{j2})	0.079	173
Joint 3 (θ_{j3})	0.119	
Distance (θ_d)	0.185	

The joint 2 and joint 3 angles are refer to θ_{j2} , θ_{j3} , θ_d in [Measurement Poses and Conditions](#)(p. 58).

M0617 Stop Category 1

Stop Distance and Stop Time of Joint 1 (Base)

Stop Distance at 33% of Max. Load (deg)	Stop Time at 33% of Max. Load (s)
---	-----------------------------------

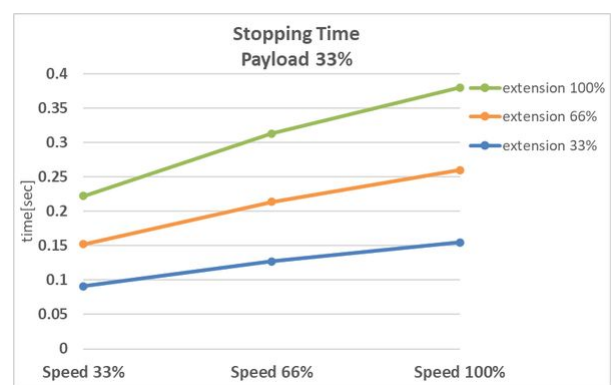
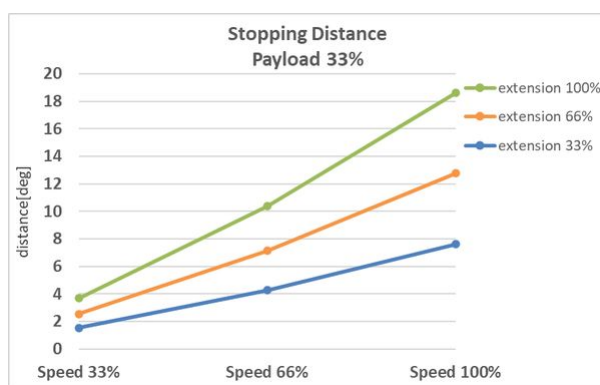

Stop Distance at 66% of Max. Load (deg)

Stop Time at 66% of Max. Load (s)

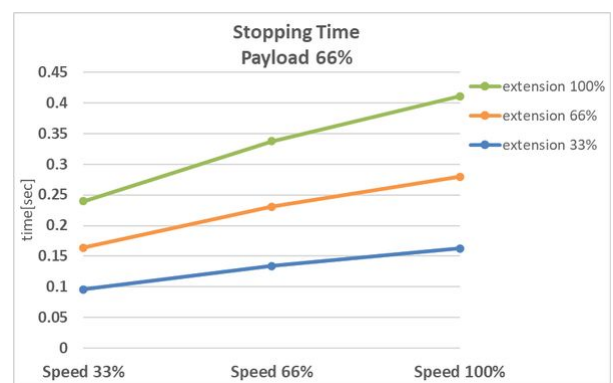
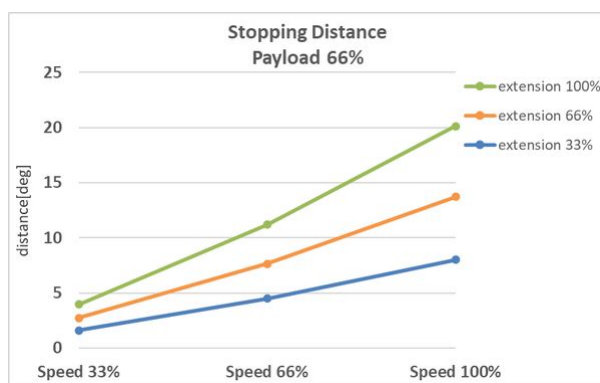

Stop Distance at Max. Load (deg)

Stop Time at Max. Load (s)

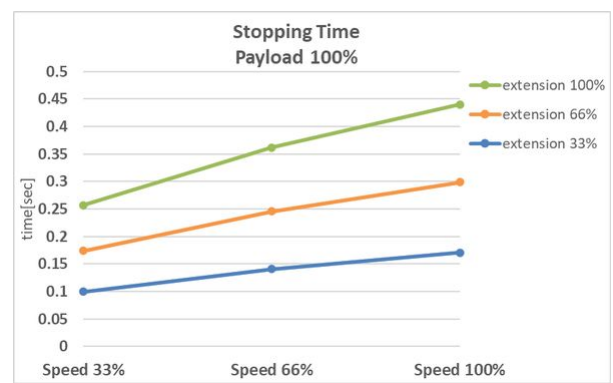
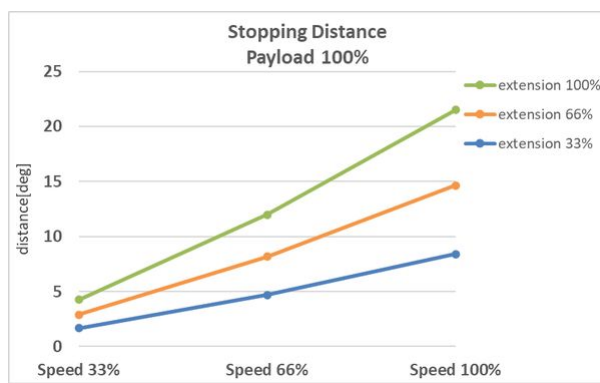

Stop Distance and Stop Time of Joint 2 (Shoulder)

Stop Distance at 33% of Max. Load (deg)

Stop Time at 33% of Max. Load (s)

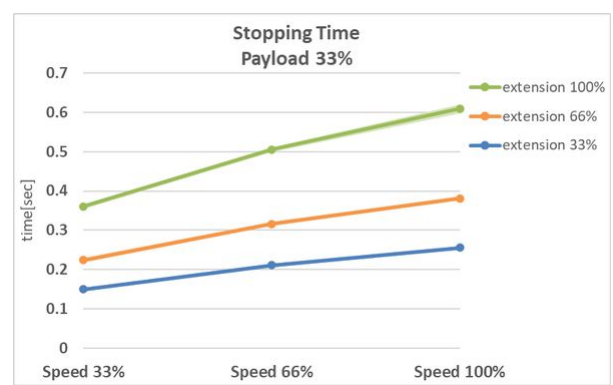
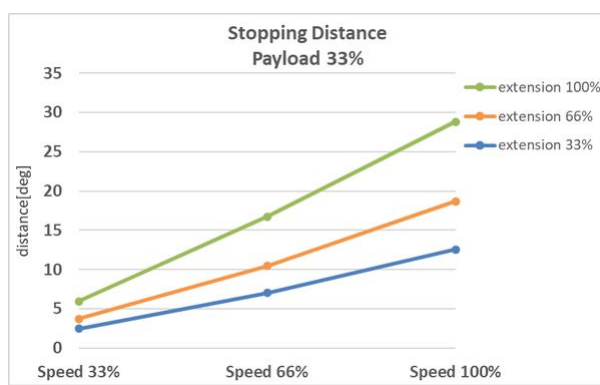

Stop Distance at 66% of Max. Load (deg)

Stop Time at 66% of Max. Load (s)

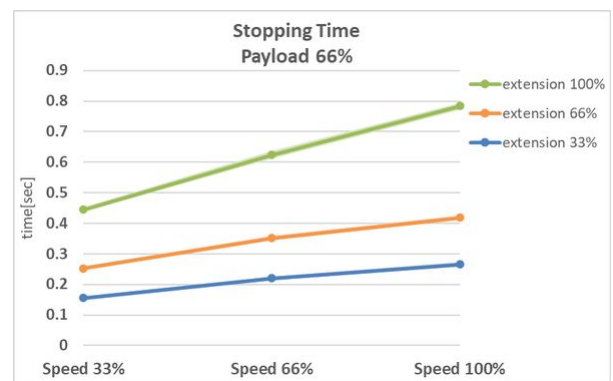

Stop Distance at Max. Load (deg)

Stop Time at Max. Load (s)

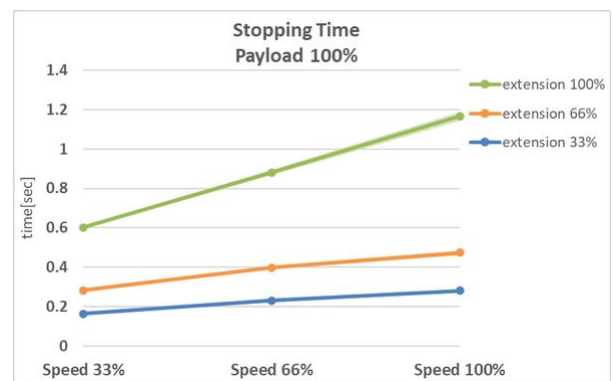
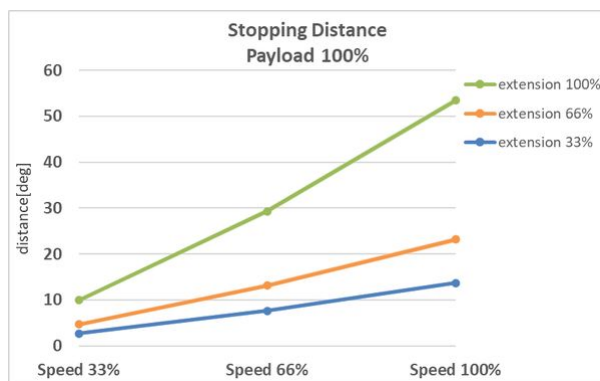

Stop Distance and Stop Time of Joint 3 (Elbow)

Stop Distance at 33% of Max. Load (deg)

Stop Time at 33% of Max. Load (s)

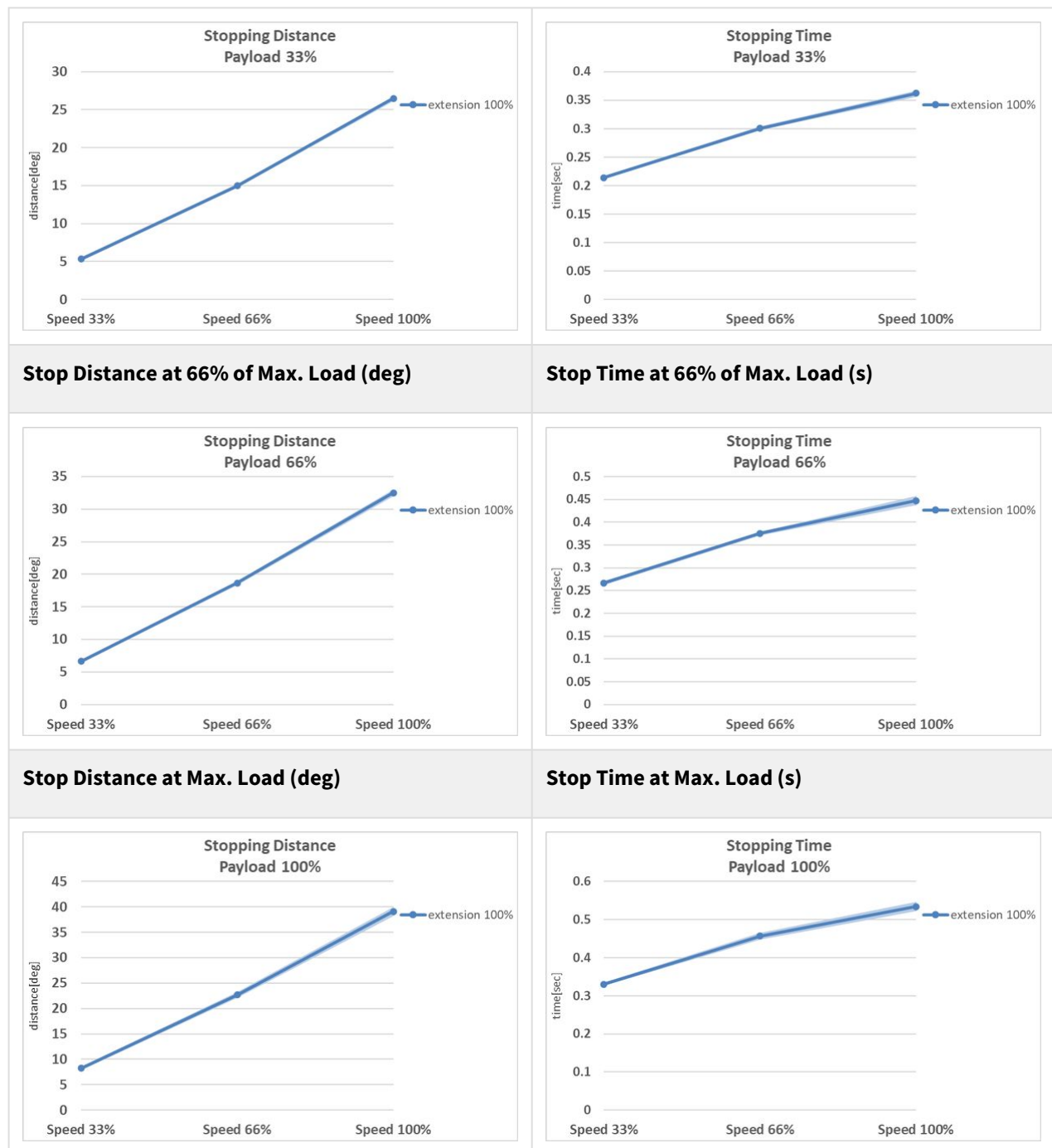

1.16.5 M1509 Stop Category

M1509 Stop Category 0

Joint 1

Extension=100%, Speed=100%, Payload=100%

	Stopping distance (rad)	Stopping time (ms)
Joint 1	0.138	109

Joint 2

Extension=100%, Speed=100%, Payload=100%

	Stopping distance (rad)	Stopping time (ms)
Joint 2 (θ_{j2})	0.105	327
Joint 3 (θ_{j3})	0.492	
Distance (θ_d)	0.338	

Joint 3

Extension=100%, Speed=100%, Payload=100%

	Stopping distance (rad)	Stopping time (ms)
Joint 2 (θ_{j2})	0.155	197
Joint 3 (θ_{j3})	0.134	
Distance (θ_d)	0.258	

The joint 2 and joint 3 angles are refer to θ_{j2} , θ_{j3} , θ_d in [Measurement Poses and Conditions](#)(p. 58).

M1509 Stop Category 1

Stop Distance and Stop Time of Joint 1 (Base)

Stop Distance at 33% of Max. Load (deg)	Stop Time at 33% of Max. Load (s)
---	-----------------------------------

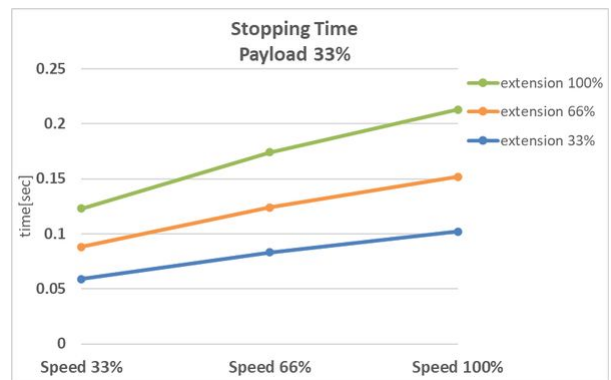
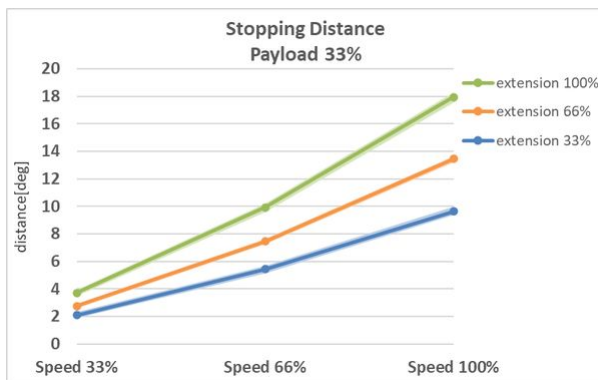

Stop Distance at 66% of Max. Load (deg)

Stop Time at 66% of Max. Load (s)

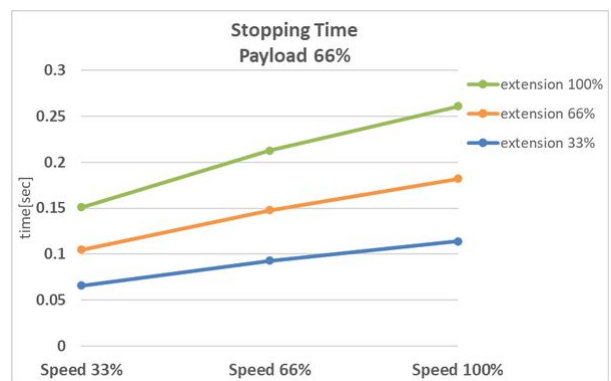

Stop Distance at Max. Load (deg)

Stop Time at Max. Load (s)

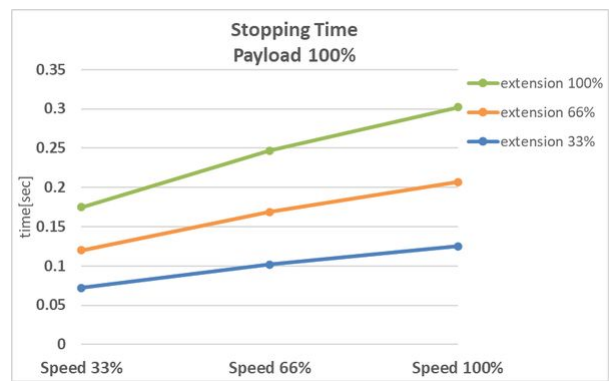
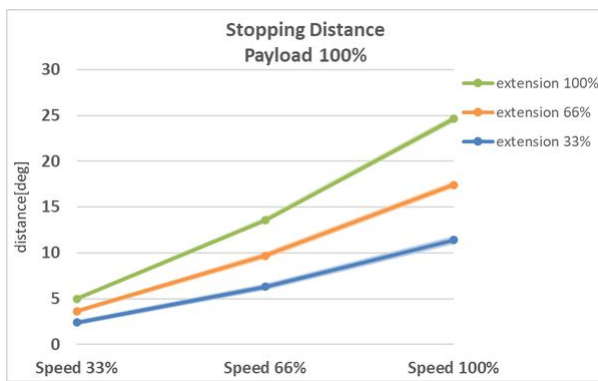

Stop Distance and Stop Time of Joint 2 (Shoulder)

Stop Distance at 33% of Max. Load (deg)

Stop Time at 33% of Max. Load (s)

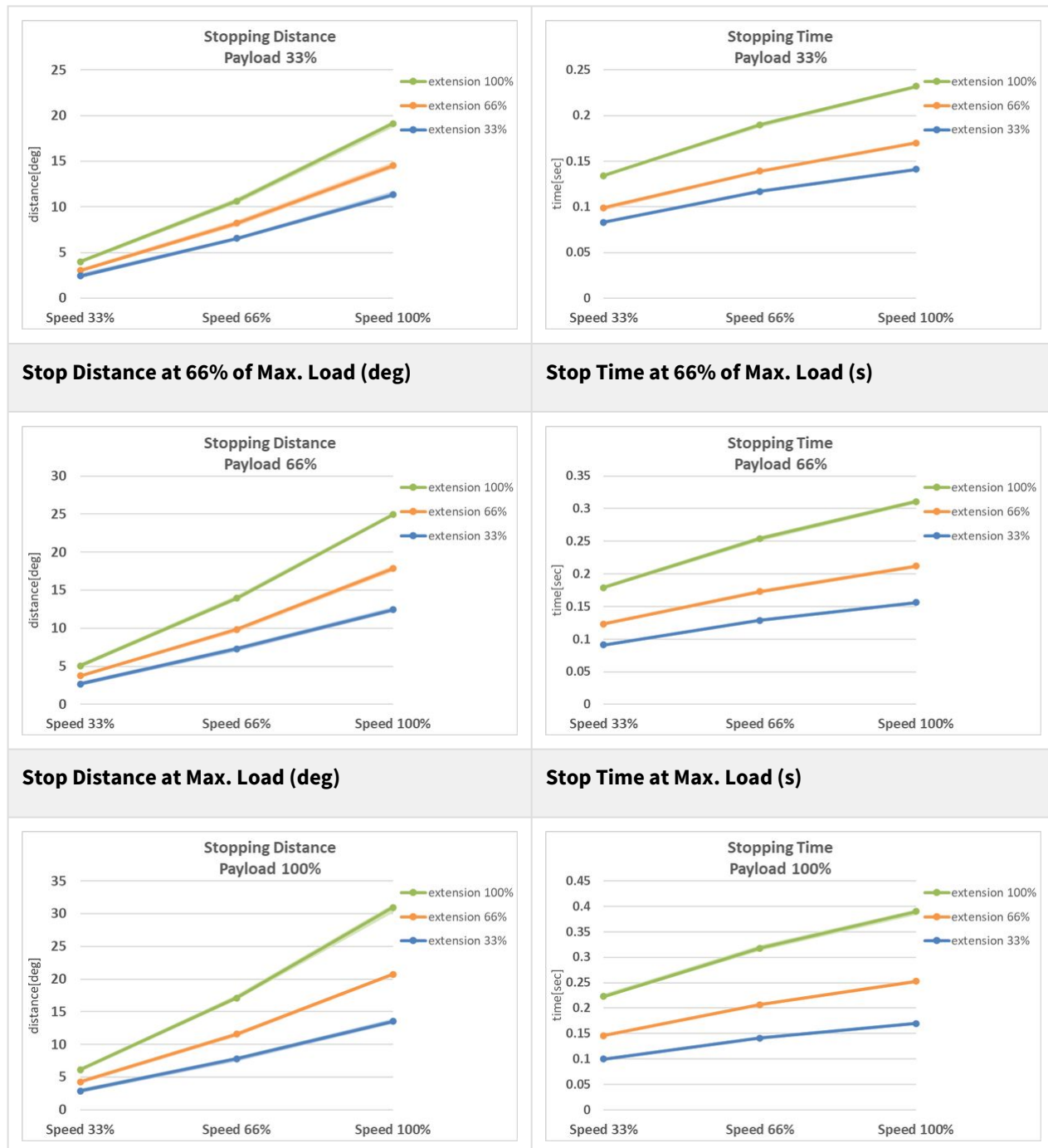

Stop Distance and Stop Time of Joint 3 (Elbow)

Stop Distance at 33% of Max. Load (deg)	Stop Time at 33% of Max. Load (s)
--	--

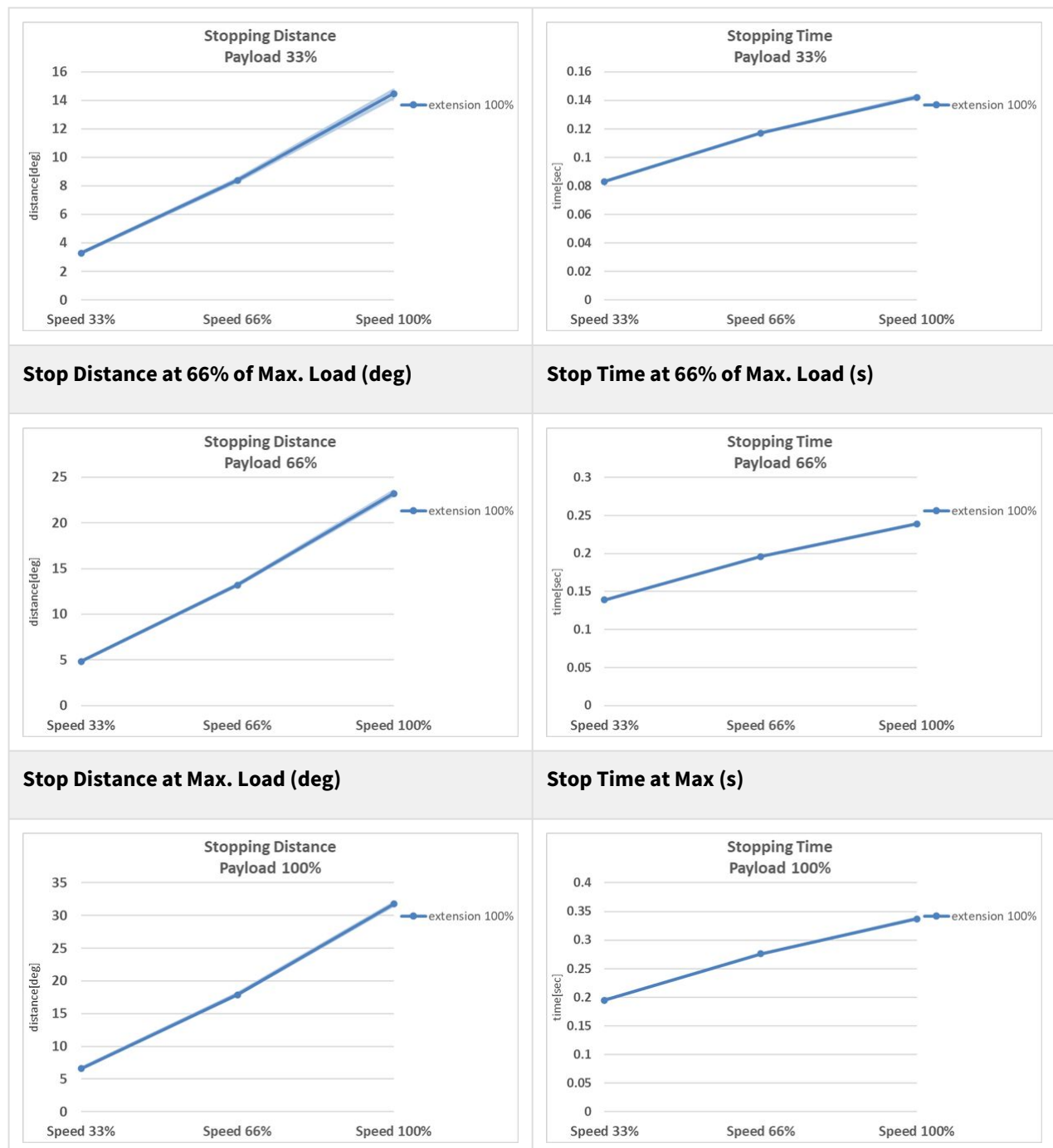

1.16.6 H2017 Stop Category

H2017 Stop Category 0

Joint 1

Extension=100%, Speed=100%, Payload=100%

	Stopping distance (rad)	Stopping time (ms)
Axis 1	0.12483	98.867

Joint 2

Extension=100%, Speed=100%, Payload=100%

	Stopping distance (rad)	Stopping time (ms)
Axis 2	0.09471	296.568
Axis 3	0.44703	

Joint 3

Extension=100%, Speed=100%, Payload=100%

	Stopping distance (rad)	Stopping time (ms)
Axis 2	0.14045	178.785
Axis 3	0.12168	

H2017 Stop Category 1

Stop Distance and Stop Time of Joint 1 (Base)

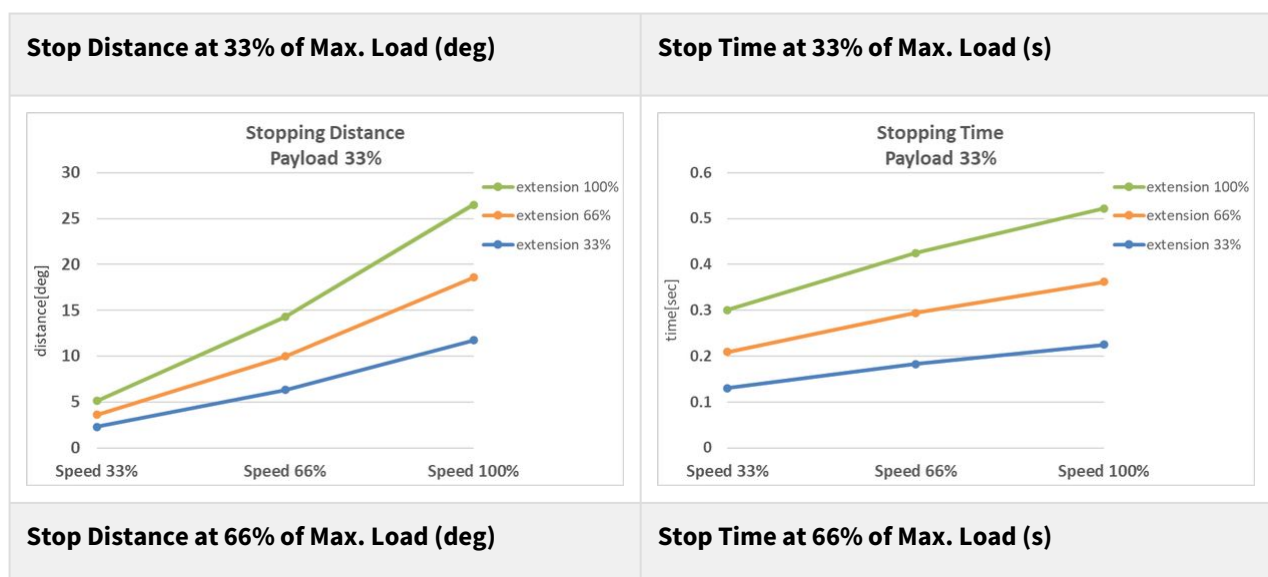

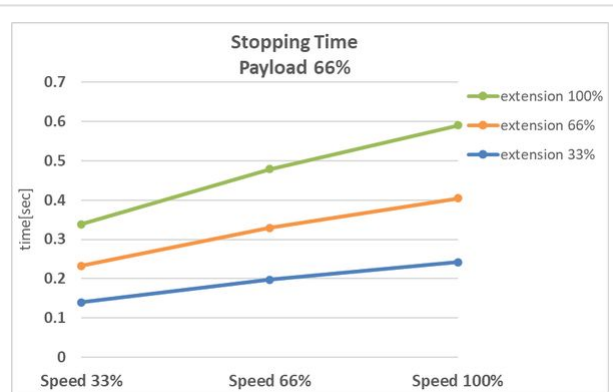
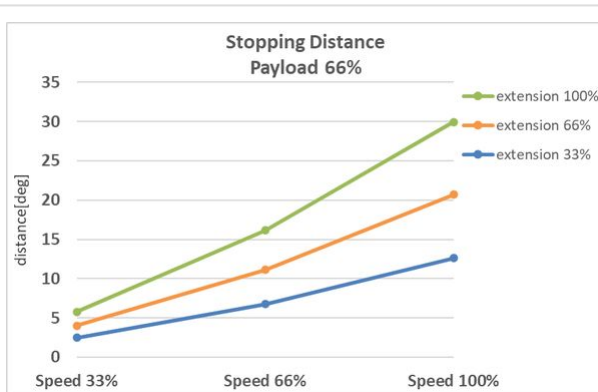

Stop Distance at Max. Load (deg)

Stop Time at Max. Load (s)

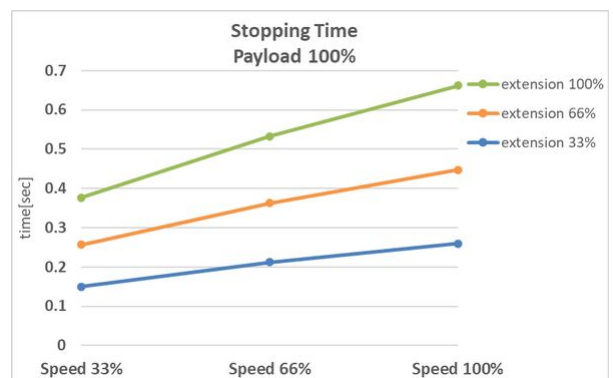
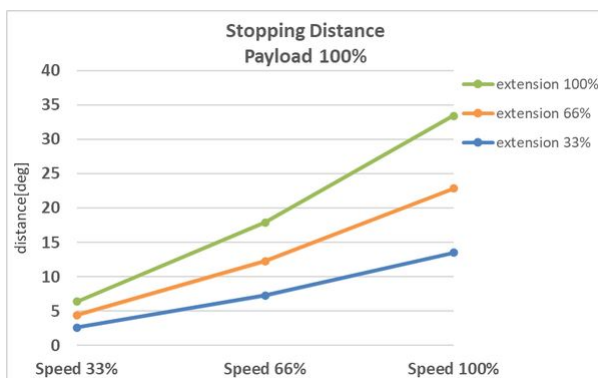

Stop Distance and Stop Time of Joint 2 (Shoulder)

Stop Distance at 33% of Max. Load (deg)

Stop Time at 33% of Max. Load (s)

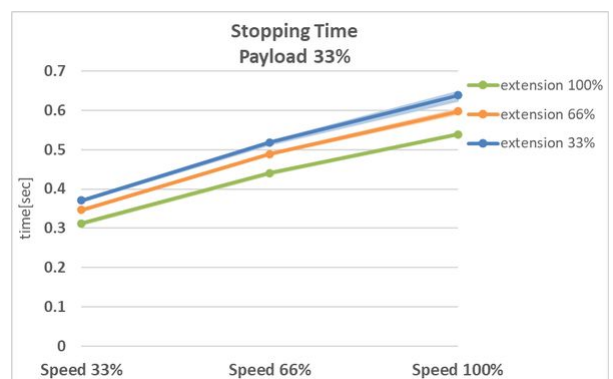
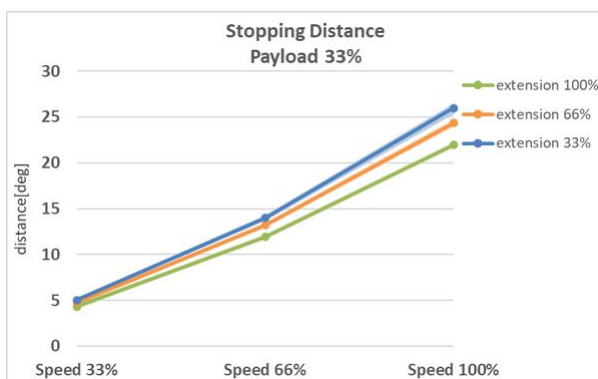

Stop Distance at 66% of Max. Load (deg)

Stop Time at 66% of Max. Load (s)

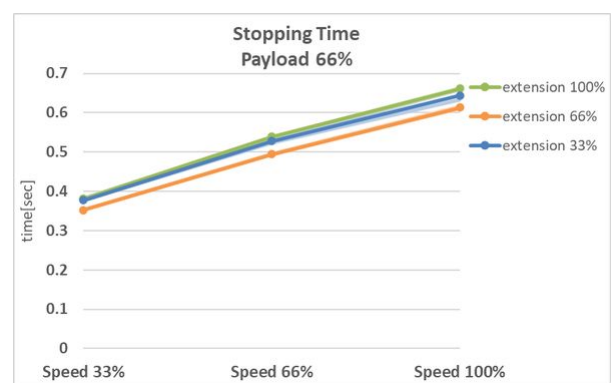
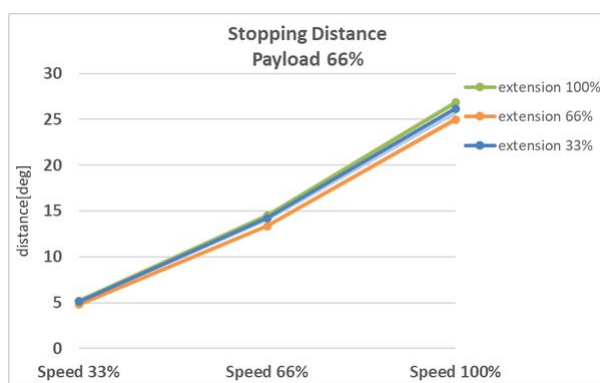

Stop Distance at Max. Load (deg)

Stop Time at Max. Load (s)

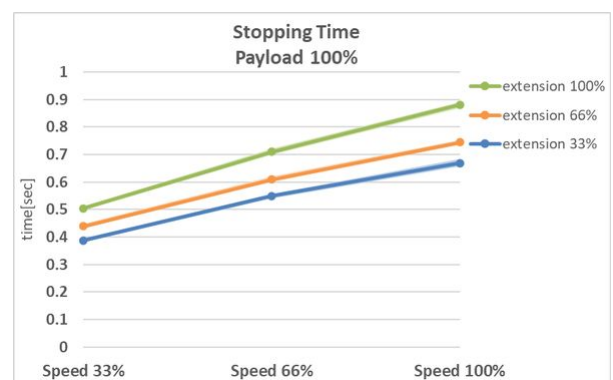
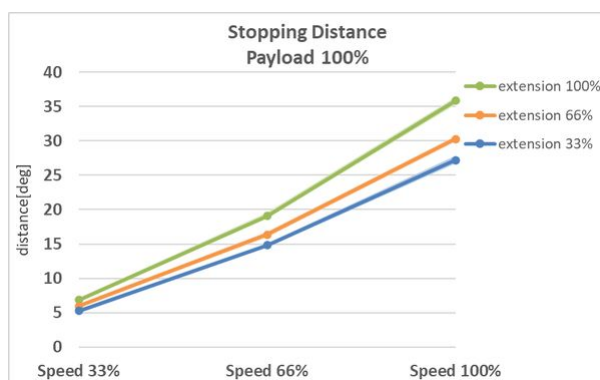

Stop Distance and Stop Time of Joint 3 (Elbow)

Stop Distance at 33% of Max. Load (deg)

Stop Time at 33% of Max. Load (s)

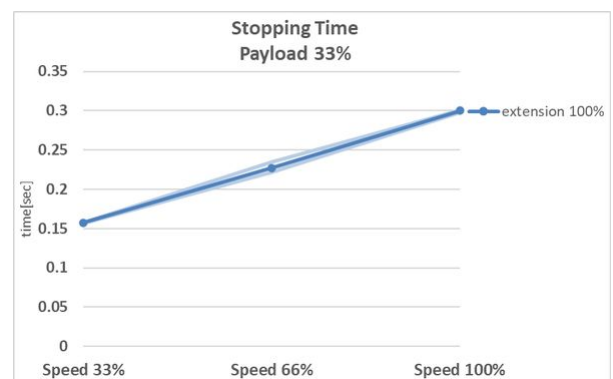
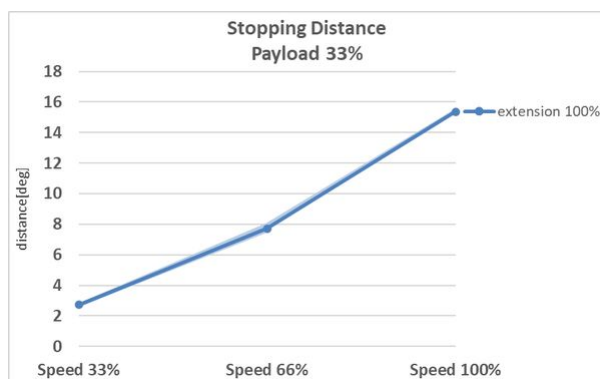

Stop Distance at 66% of Max. Load (deg)

Stop Time at 66% of Max. Load (s)

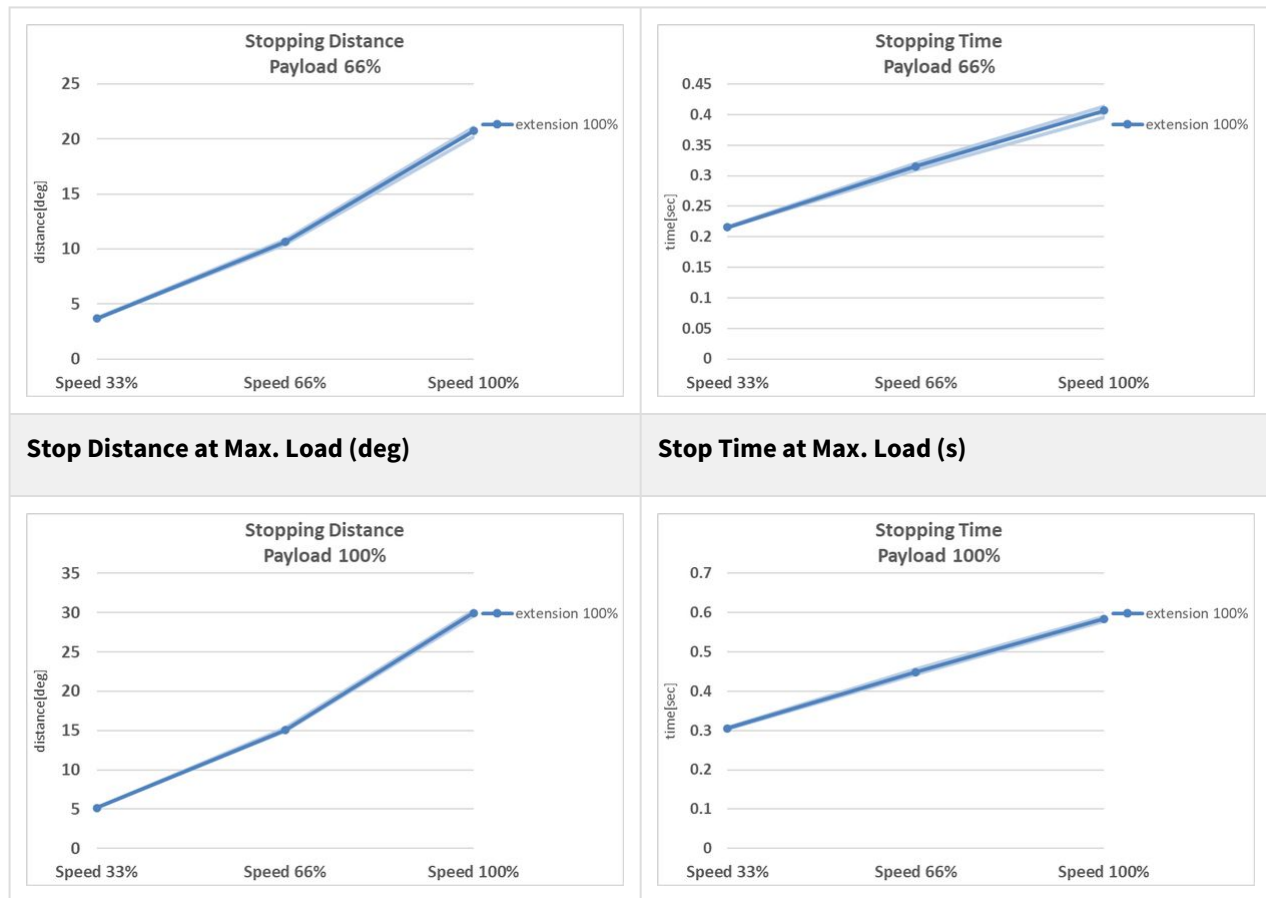
**Stop Distance at Max. Load (deg)****Stop Time at Max. Load (s)**

1.16.7 H2515 Stop Category

H2515 Stop Category 0

Joint 1

Extension=100%, Speed=100%, Payload=100%

	Stopping distance (rad)	Stopping time (ms)
Axis 1	0.12483	98.867

Joint 2

Extension=100%, Speed=100%, Payload=100%

	Stopping distance (rad)	Stopping time (ms)
Axis 2	0.09471	296.568

	Stopping distance (rad)	Stopping time (ms)
Axis 3	0.44703	

Joint 3

Extension=100%, Speed=100%, Payload=100%

	Stopping distance (rad)	Stopping time (ms)
Axis 2	0.14045	178.785
Axis 3	0.12168	

H2515 Stop Category 1

Stop Distance and Stop Time of Joint 1 (Base)

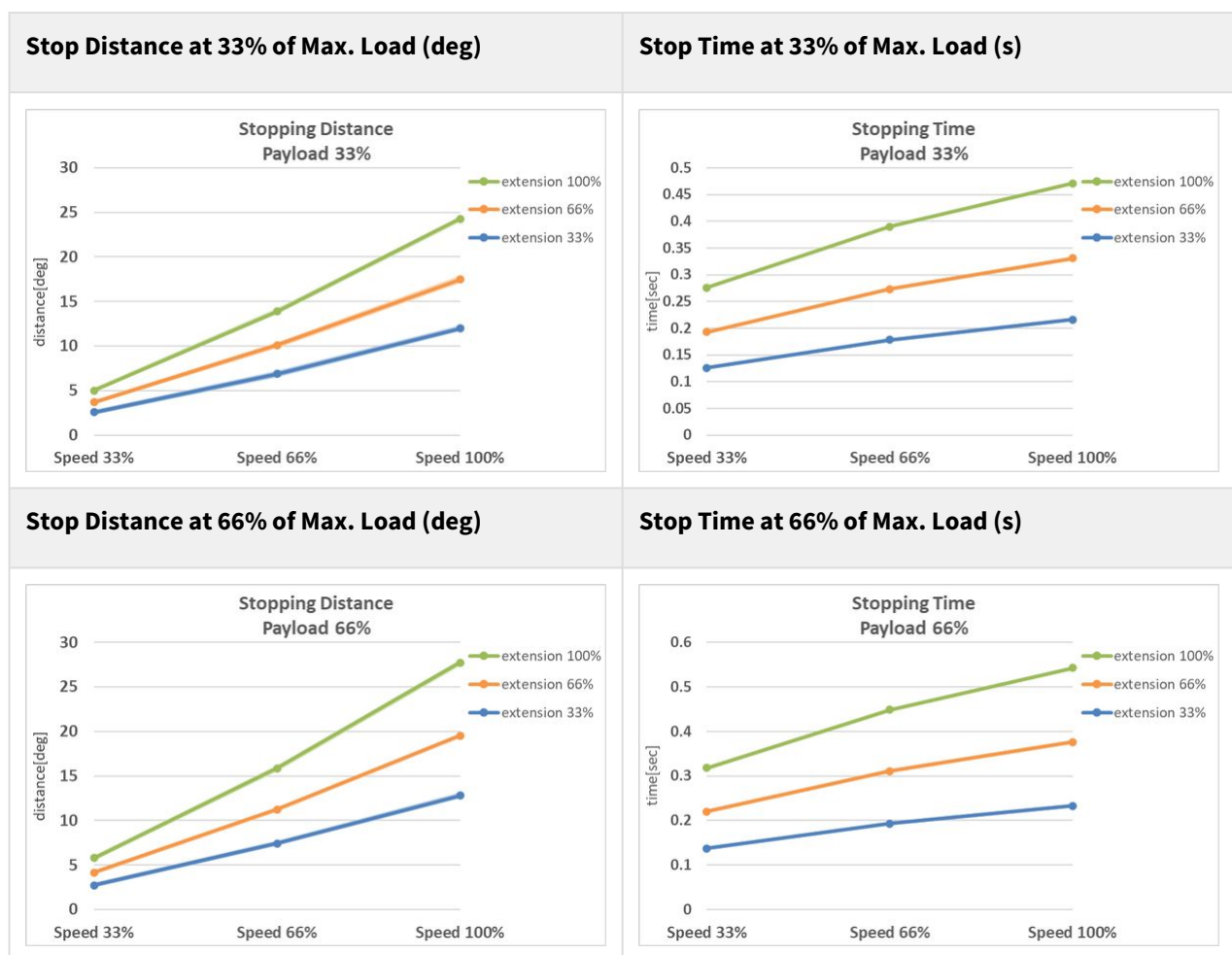

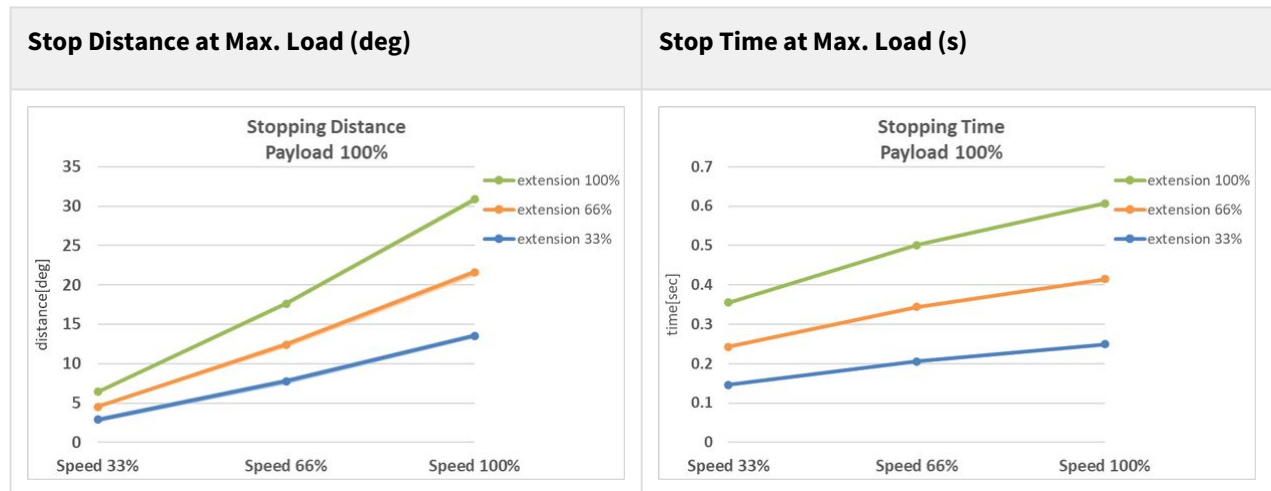

Stop Distance and Stop Time of Joint 2 (Shoulder)

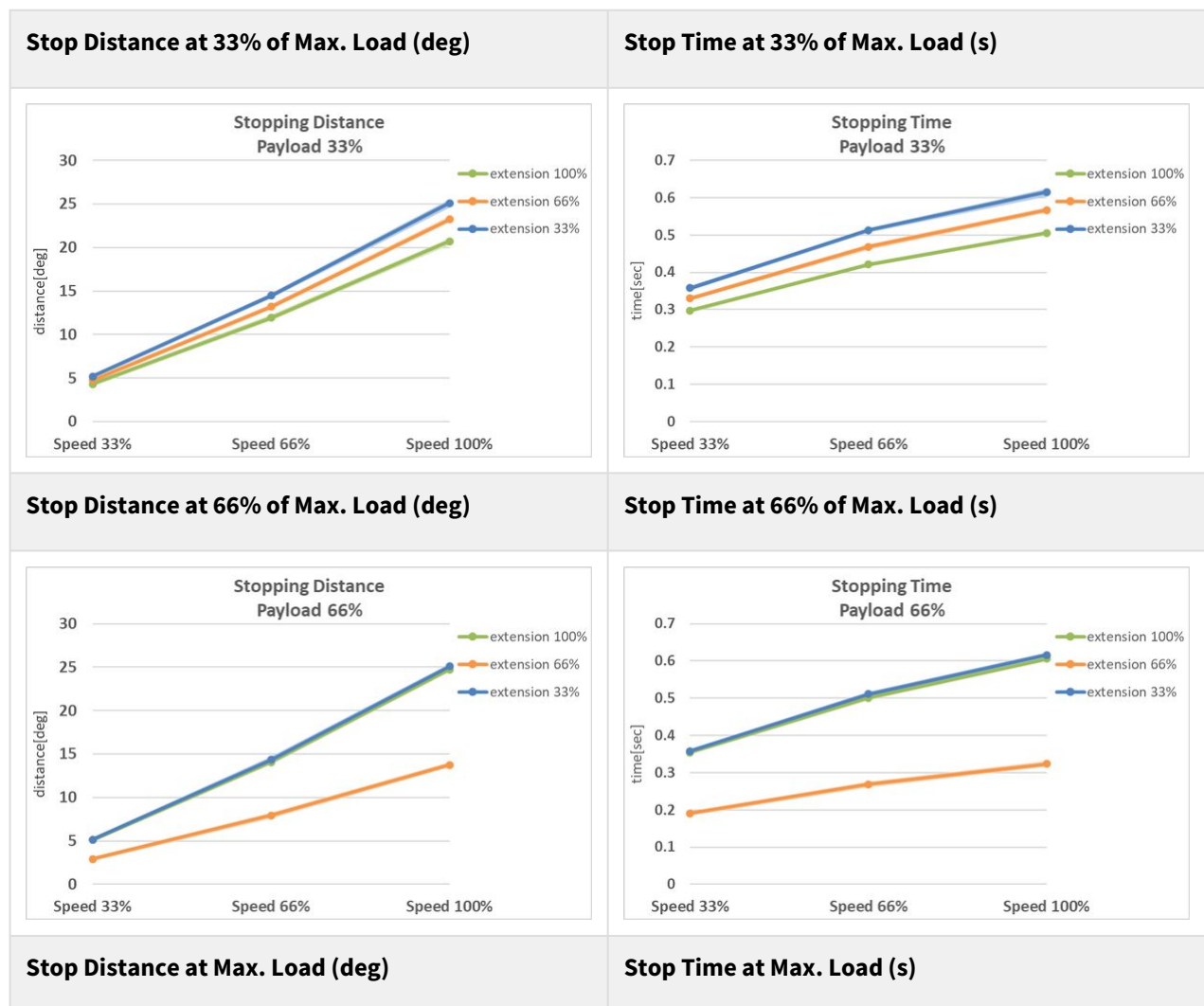

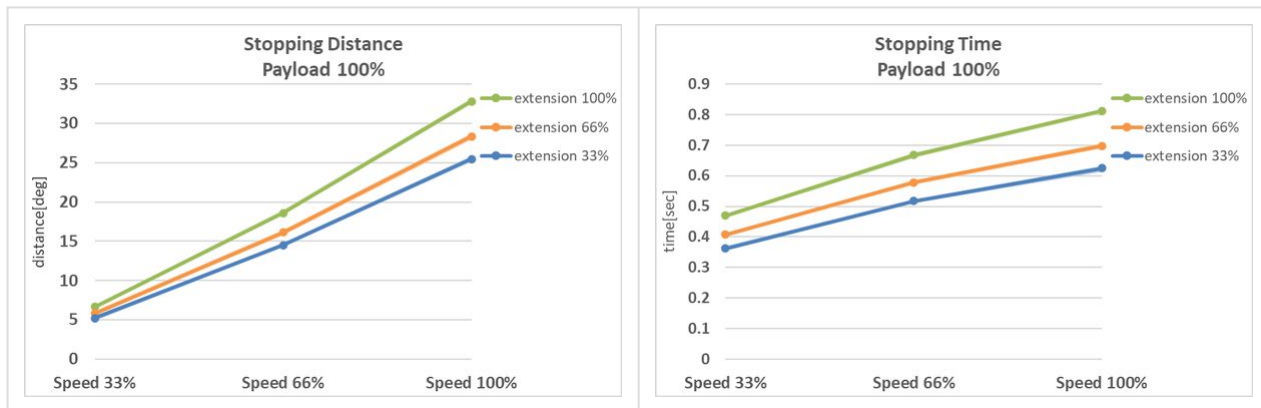

Stop Distance and Stop Time of Joint 3 (Elbow)

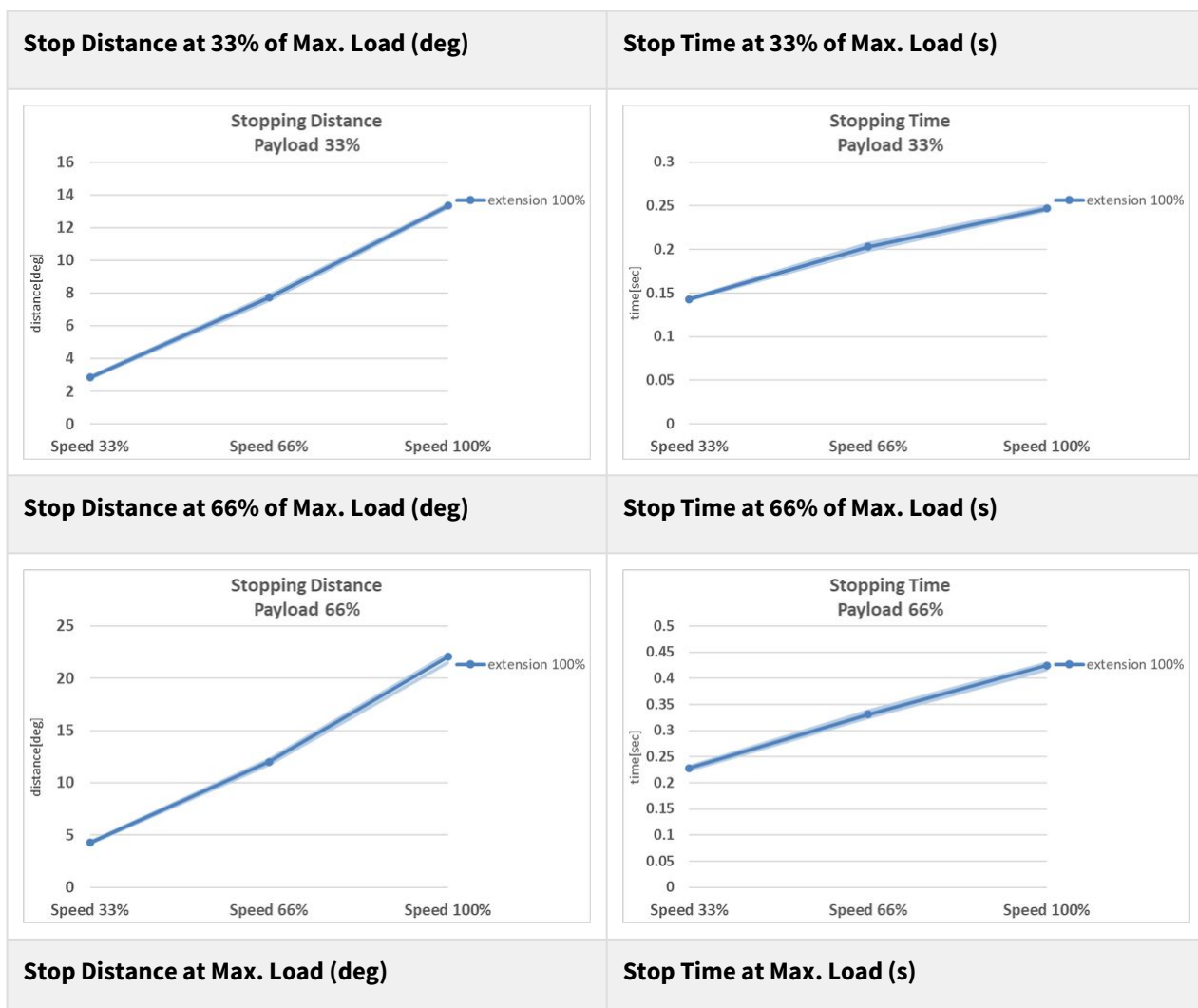

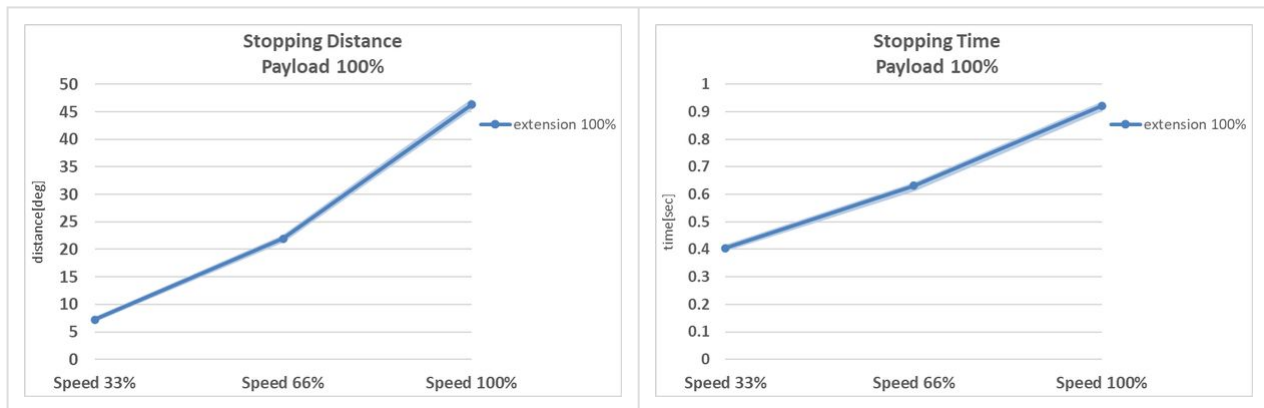

1.17 Upper/Lower Threshold Range and Default Value of Safety Parameters

1.17.1 M1013

Parameters		Normal			Reduced			Tolerance (+/-)
		Min	Max	Default	Min	Max	Default	
Joint Angle Limits	J1 (degree)	-360	360	-360~360	-360	360	-360~360	3/-3
	J2 (degree)	-360	360	-95~95	-360	360	-95~95	3/-3
	J3 (degree)	-160	160	-135~135	-160	160	-135~135	3/-3
	J4 (degree)	-360	360	-360~360	-360	360	-360~360	3/-3
	J5 (degree)	-360	360	-135~135	-360	360	-135~135	3/-3
	J6 (degree)	-360	360	-360~360	-360	360	-360~360	3/-3
Joint Speed Limits	J1 (degree/s)	0	120	120	0	120	120	10
	J2 (degree/s)	0	120	120	0	120	120	10
	J3 (degree/s)	0	180	180	0	180	180	10
	J4 (degree/s)	0	225	225	0	225	225	10
	J5 (degree/s)	0	225	225	0	225	225	10

	J6 (degree/s)	0	225	225	0	225	225	10
Robot/TCP Limits	Force (N)	0	550	144	0	550	72	-
	Power (W)	0	1600	600	0	1600	100	-
	Speed (mm/s)	0	8000	2000	0	8000	1500	-
	Momentum (kgm/s)	0	165	82	0	165	50	-
	Collision Detection Sensitivity (%)	1	100	75	-	-	-	-
Safety I/O	Speed Reduction Ratio (%)	-	-	-	1	100	20	-

1.17.2 M0609

Parameters		Normal			Reduced			Tolerance (+/-)
		Min	Max	Default	Min	Max	Default	
Joint Angle Limits	J1 (degree)	-360	360	-360~360	-360	360	-360~360	3/-3
	J2 (degree)	-360	360	-95~95	-360	360	-95~95	3/-3
	J3 (degree)	-150	150	-135~135	-150	150	-135~135	3/-3
	J4 (degree)	-360	360	-360~360	-360	360	-360~360	3/-3
	J5 (degree)	-360	360	-135~135	-360	360	-135~135	3/-3
	J6 (degree)	-360	360	-360~360	-360	360	-360~360	3/-3
Joint Speed Limits	J1 (degree/s)	0	150	150	0	150	150	10
	J2 (degree/s)	0	150	150	0	150	150	10
	J3 (degree/s)	0	180	180	0	180	180	10

	J4 (degree/s)	0	225	225	0	225	225	10
	J5 (degree/s)	0	225	225	0	225	225	10
	J6 (degree/s)	0	225	225	0	225	225	10
Robot/TCP Limits	Force (N)	0	400	96	0	400	48	-
	Power (W)	0	1600	300	0	1600	80	-
	Speed (mm/s)	0	7000	2000	0	7000	1000	-
	Momentum (kgm/s)	0	75	38	0	75	23	-
	Collision Detection Sensitivity (%)	1	100	75	-	-	-	-
Safety I/O	Speed Reduction Ratio (%)	-	-	-	1	100	20	-

1.17.3 M0617

Parameters		Normal			Reduced			Tolerance (+/-)
		Min	Max	Default	Min	Max	Default	
Joint Angle Limits	J1 (degree)	-360	360	-360~360	-360	360	-360~360	3/-3
	J2 (degree)	-360	360	-95~95	-360	360	-95~95	3/-3
	J3 (degree)	-165	165	-145~145	-165	165	-145~145	3/-3
	J4 (degree)	-360	360	-360~360	-360	360	-360~360	3/-3
	J5 (degree)	-360	360	-135~135	-360	360	-135~135	3/-3
	J6 (degree)	-360	360	-360~360	-360	360	-360~360	3/-3
Joint Speed Limits	J1 (degree/s)	0	100	100	0	100	100	10

	J2 (degree/s)	0	100	100	0	100	100	10
	J3 (degree/s)	0	150	150	0	150	150	10
	J4 (degree/s)	0	225	225	0	225	225	10
	J5 (degree/s)	0	225	225	0	225	225	10
	J6 (degree/s)	0	225	225	0	225	225	10
Robot/TCP Limits	Force (N)	0	500	108	0	500	54	-
	Power (W)	0	1600	600	0	1600	100	-
	Speed (mm/s)	0	8000	2000	0	8000	1500	-
	Momentum (kgm/s)	0	180	90	0	180	55	-
	Collision Detection Sensitivity (%)	1	100	75	-	-	-	-
Safety I/O	Speed Reduction Ratio (%)	-	-	-	1	100	20	-

1.17.4 M1509

Parameters		Normal			Reduced			Tolerance (+/-)
		Min	Max	Default	Min	Max	Default	
Joint Angle Limits	J1 (degree)	-360	360	-360~360	-360	360	-360~360	3/-3
	J2 (degree)	-360	360	-95~95	-360	360	-95~95	3/-3
	J3 (degree)	-150	150	-135~135	-150	150	-135~135	3/-3
	J4 (degree)	-360	360	-360~360	-360	360	-360~360	3/-3
	J5 (degree)	-360	360	-135~135	-360	360	-135~135	3/-3

	J6 (degree)	-360	360	-360~360	-360	360	-360~360	3/-3
Joint Speed Limits	J1 (degree/s)	0	150	150	0	150	150	10
	J2 (degree/s)	0	150	150	0	150	150	10
	J3 (degree/s)	0	180	180	0	180	180	10
	J4 (degree/s)	0	225	225	0	225	225	10
	J5 (degree/s)	0	225	225	0	225	225	10
	J6 (degree/s)	0	225	225	0	225	225	10
Robot/TCP Limits	Force (N)	0	800	162	0	800	81	-
	Power (W)	0	1600	650	0	1600	120	-
	Speed (mm/s)	0	7000	2000	0	7000	1000	-
	Momentum (kgm/s)	0	135	68	0	135	40	-
	Collision Detection Sensitivity (%)	1	100	75	-	-	-	-
Safety I/O	Speed Reduction Ratio (%)	-	-	-	1	100	20	-

1.17.5 H2017

Parameters		Normal			Reduced			Tolerance (+/-)
		Min	Max	Default	Min	Max	Default	
Joint Angle Limits	J1 (degree)	-360	360	-360~360	-360	360	-360~360	3/-3
	J2 (degree)	-125	125	-95~95	-125	125	-95~95	3/-3
	J3 (degree)	-160	160	-145~145	-160	160	-145~145	3/-3

	J4 (degree)	-360	360	-360~360	-360	360	-360~360	3/-3
	J5 (degree)	-360	360	-135~135	-360	360	-135~135	3/-3
	J6 (degree)	-360	360	-360~360	-360	360	-360~360	3/-3
Joint Speed Limits	J1 (degree/s)	0	80	80	0	80	80	10
	J2 (degree/s)	0	80	80	0	80	80	10
	J3 (degree/s)	0	80	80	0	80	80	10
	J4 (degree/s)	0	180	180	0	180	180	10
	J5 (degree/s)	0	180	180	0	180	180	10
	J6 (degree/s)	0	180	180	0	180	180	10
Robot/TCP Limits	Force (N)	0	1200	243	0	1200	122	-
	Power (W)	0	1600	800	0	1600	650	-
	Speed (mm/s)	0	2500	2000	0	2500	1500	-
	Momentum (kgm/s)	0	400	200	0	400	122	-
	Collision Detection Sensitivity (%)	1	100	75	-	-	-	-
Safety I/O	Speed Reduction Ratio (%)	-	-	-	1	100	20	-

1.17.6 H2515

Parameters		Normal			Reduced			Tolerance (+/-)
		Min	Max	Default	Min	Max	Default	
Joint Angle Limits	J1 (degree)	-360	360	-360~360	-360	360	-360~360	3/-3

	J2 (degree)	-125	125	-95~95	-125	125	-95~95	3/-3
	J3 (degree)	-160	160	-145~145	-160	160	-145~145	3/-3
	J4 (degree)	-360	360	-360~360	-360	360	-360~360	3/-3
	J5 (degree)	-360	360	-135~135	-360	360	-135~135	3/-3
	J6 (degree)	-360	360	-360~360	-360	360	-360~360	3/-3
Joint Speed Limits	J1 (degree/s)	0	100	100	0	100	100	10
	J2 (degree/s)	0	80	80	0	80	80	10
	J3 (degree/s)	0	100	100	0	100	100	10
	J4 (degree/s)	0	180	180	0	180	180	10
	J5 (degree/s)	0	180	180	0	180	180	10
	J6 (degree/s)	0	180	180	0	180	180	10
Robot/TCP Limits	Force (N)	0	1200	243	0	1200	122	-
	Power (W)	0	1600	800	0	1600	650	-
	Speed (mm/s)	0	2500	2000	0	2500	1500	-
	Momentum (kgm/s)	0	400	200	0	400	122	-
	Collision Detection Sensitivity (%)	1	100	75	-	-	-	-
Safety I/O	Speed Reduction Ratio (%)	-	-	-	1	100	20	-

2 PART 2. Starting Up the Robot

From Starting Up the Robot, the user can learn the overall process from robot installation to robot operation. Install the robot according to the following 4 steps, and create a task program to execute:

- [Step 1. Robot Installation\(p. 94\)](#) : Install the robot and connect the controller and teach pendant.
- [Step 2. Tool Installation and I/O Testing\(p. 104\)](#) : Install the tool and test the I/O signal.
- [Step 3. Robot Operation and Setting\(p. 108\)](#) : Learn how to operate the robot manually and add robot settings and Workcell Items.
- [Step 4. Create Task Program\(p. 120\)](#) : Learn how to operate the robot automatically and learn about basic motions, compliance/force control and Pick & Place skill samples.

2.1 Journey Map

The journey map lists the process from the installation of Doosan Robotics robot to actual operation in sequential order. Refer to each guide item to begin using the robot.

2.1.1 Step 1. Robot Installation

	Classification	Work	Mandatory Work	Difficulty	Time (Minutes)
1	Robot Installation	Remove packing	✓	EASY	3
2		Connect cable to the controller	✓	EASY	1
3		Secure the robot base	✓	EASY	3
4		Connect controller to robot	✓	EASY	1
5		Connect power to controller	✓	EASY	1
6		Position controller	✓	EASY	1
7	Initial start Up	Power-up controller	✓	EASY	3
8		Disengage emergency stop button	✓	EASY	1
9		Disengage packaging pose	✓	EASY	3
10		Servo Off	✓	EASY	1

2.1.2 Step 2. Tool Installation and I/O Testing

	Classification	Work	Mandatory Work	Difficulty	Time (Minutes)
1	Tool Installation	Install tool	✓	EASY	5
2	I/O Testing	Turn system power off	✓	EASY	1
3		Connect wires	✓	NORMAL	10
4		Turn system power on	✓	EASY	1
5		Test controller and flange I/O	✓	NORMAL	10

2.1.3 Step 3. Robot Operation and Setting

	Classification	Work	Mandatory Work	Difficulty	Time (Minutes)
1	Safety Stop	Learn how to engage/disengage Safety Stop	✓	EASY	5
2	Manual Operation	Learn how to perform safety recovery/powerless motion	✓	NORMAL	15
3		Learn how to use jog	✓	NORMAL	15
4		Learn how to perform direct teach	✓	EASY	5
5	Settings	Disengage the Password Lock	✓	EASY	1
6	Workcell Manager	Learn about Workcell Manager and Workcell Item	✓	EASY	5
7	Robot Settings (Standard Workcell Item Settings)	Set robot limits	✓	EASY	5
8		Set World Coordinates	OPTIONAL	NORMAL	3

	Classification	Work	Mandatory Work	Difficulty	Time (Minutes)
9	Add Workcell Item	Add robot installation pose (Mount)	OPTIONAL	EASY	3
10		Add Tool Weight	✓	EASY	5
11		Add Tool Shape	✓	EASY	5
12		Add End Effector	✓	NORMAL	10
13		Add Space Limit	OPTIONAL	NORMAL	10

2.1.4 Step 4. Create Task Program

	Classification	Work	Mandatory Work	Difficulty	Time (Minutes)
1	Task Programming	Start programming	✓	EASY	3
2	Motion Robot Utilization	Understand robot motion	✓	EASY	5
3		Understand robot motion properties	✓	NORMAL	15
4		Try MoveJ/MoveL command samples	✓	NORMAL	20
5	Compliance/Force Control Utilization	Understand Compliance/Force Control	OPTIONAL	HARD	15
6		Try Compliance command samples	OPTIONAL	NORMAL	20
7		Try Force command samples	OPTIONAL	NORMAL	20
8	Use skills	Try Pick & Place samples	OPTIONAL	NORMAL	20
9	Miscellaneous Functions	Utilize Sub/Call Sub	OPTIONAL	NORMAL	5
10		Utilize debugging	OPTIONAL	NORMAL	5

2.2 Step 1. Robot Installation

In this step, you can learn how to install and initially start up the Doosan Robotics robot.

Caution

- Before installing the robot, make sure to read and follow [Cautions during Installation\(p. 180\)](#) and [Installation Environment\(p. 182\)](#).
- For more information about robot installation, refer to [PART 3. Installation Manual\(p. 166\)](#).
- Before installing the robot, make sure to read and follow [Cautions during Installation\(p. 180\)](#) and [Installation Environment\(p. 182\)](#).
- For more information about robot installation, refer to [PART 3. Installation Manual\(p. 166\)](#).

2.2.1 Remove packing

MANDATORY **EASY** 3 MIN



Sorry, the widget is not supported in this export.
But you can reach it using the following URL:

<https://www.youtube.com/watch?v=qZ3avKrGx4M>

Upon purchasing the Doosan Robotics robot, two boxes containing the robot and controller will be delivered. Remove the packing and check the contents. For more information about the components, refer to [Component Check\(p. 166\)](#).

1. The manipulator is contained in the larger box.
2. The controller and teach pendant are contained in the smaller box.

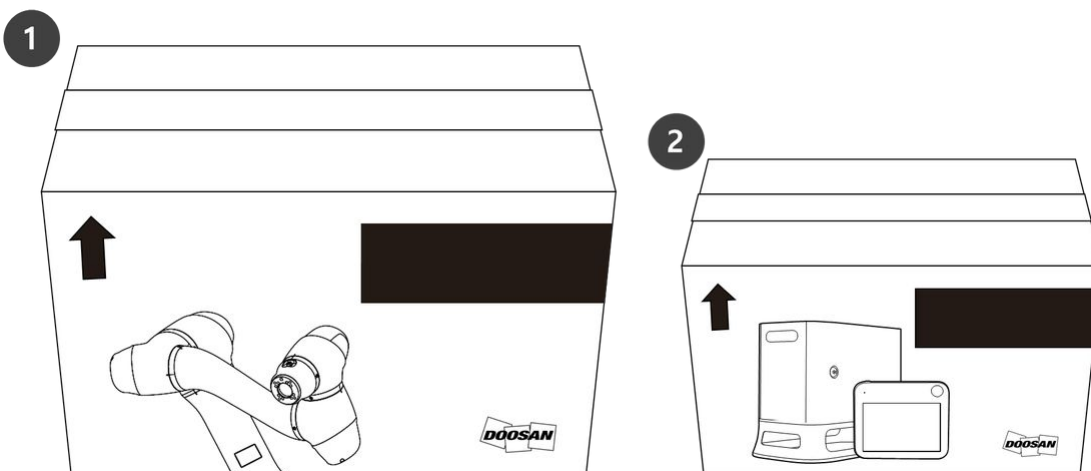

Caution

- To ensure safety during delivery, all products are wrapped and packed using solid protective materials, so take caution when removing them from the box.
- When removing the product from the box, take caution not to damage to products due to falling.

2.2.2 Connect cable to the controller

MANDATORY **EASY** 1 MIN

Connect the teach pendant and robot cable to the controller.

1. Push the teach pendant cable into the corresponding controller connector until a click is heard. This will prevent the cable from becoming loose.
2. Push the robot cable's opposite end into the corresponding controller connector until a click is heard to prevent the cable from becoming loose.

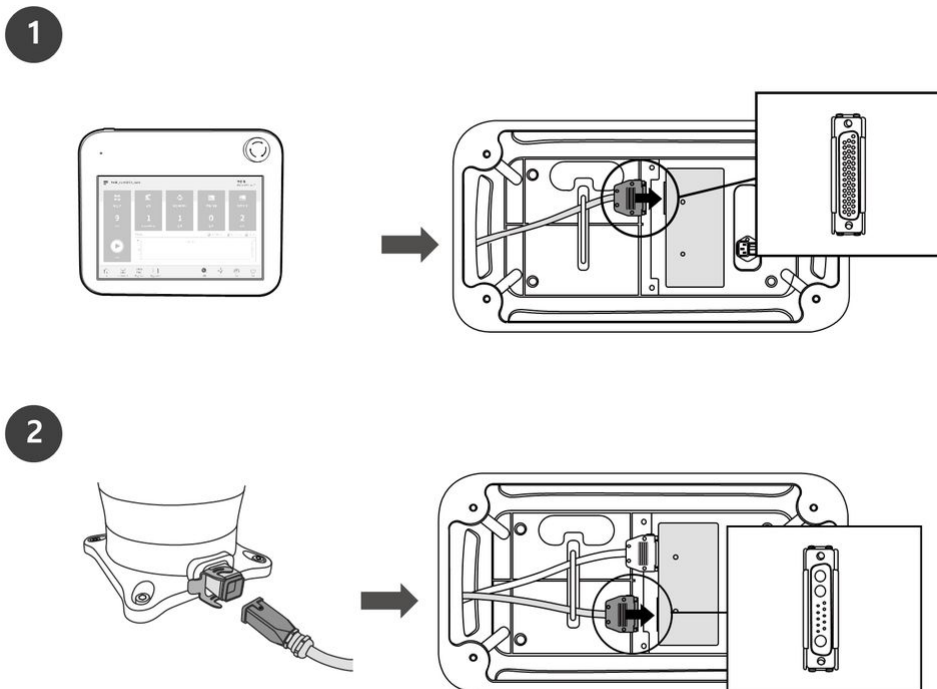

⚠ Caution

- Make sure to check that the pins in the cable end are not damaged or bent before connecting the cable.
- If the noise generated by electromagnetic waves causes issues, it is necessary to install a ferrite core to ensure normal operation. For more information about the ferrite core installation location, refer to the followings:
 - [Connecting the Manipulator and Controller](#)(p. 185)
 - [Connecting the Controller and Teach Pendant](#)(p. 186)

2.2.3 Secure the robot base

MANDATORY **EASY** 3 MIN

When securing the robot base and when installing a tool on the tool flange, the following additional components are required:

- M8 hexagonal wrench bolt: 4EA
- $\Phi 5$ place marker pin 2EA

Use M8 in the four holes in the robot base to secure the robot. For more information, refer to [Securing the Robot](#)(p. 183).

- It is recommended to use a tightening torque of 20 Nm to tighten the bolts. Use washers (spring-flat) to prevent loosening by vibration.
- Use two $\Phi 5$ place marker pins to accurately install the robot in a fixed location.

i Note

- M/A/H/E/P Ground Tap Fastening Guide

1. Ground tap added to Robot Base ('23 December related design change approval completed: ECO00371_Robot Base Ground Bolt Fastening Part Added)
2. Ground bolt is not included, users can prepare and fasten it themselves as needed
3. Ground bolt specifications: M4X4L
4. Guide text example: All robots of Doosan Robotics are provided with an external ground tap. If grounding is required depending on the usage environment, you can connect the ground wire using the M4X4L bolt. The ground tap is located near the ground label.
5. Ground label



2.2.4 Connect controller to robot

MANDATORY **EASY** 1 MIN



Sorry, the widget is not supported in this export.
But you can reach it using the following URL:

<https://www.youtube.com/watch?v=x3oWM8XPmDg>

Connect the robot cable to the corresponding controller connector and place a securing ring on it to prevent the cable from becoming loose.

- Push the robot cable's opposite end into the corresponding controller connector until a click is heard to prevent the cable from becoming loose.

2.2.5 Connect power to controller

MANDATORY **EASY** 1 MIN

To supply power to the controller, connect the power cable of the control box to a standard IEC power outlet.

- After connecting the power cable, make sure that the robot is properly grounded (electrical ground connection).
- Establish a common ground for all equipment in the system with unused bolts related to the ground symbol inside the controller. The ground conductor must satisfy the maximum current rating of the system.
- For more information, refer to [Supplying Power to the Controller](#)(p. 188).

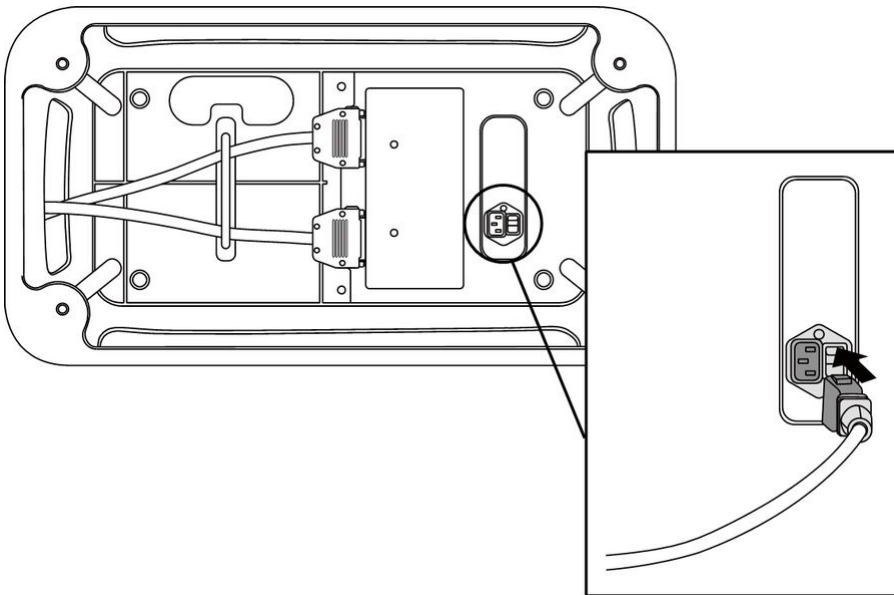

The power supply must satisfy minimum requirements such as grounding and circuit breakers. The electrical specifications of the included AC controller are as follows:

Parameter	Specifications
Input Voltage	100 – 240 VAC
Input Power Fuse (@100-240V)	15 A
Input Frequency	47 – 63 Hz

Refer to the following appendix for optional controller information.

- [Appendix. Protected AC Controller \(CS-01P\)](#)(p. 385)

- DC Controller (CS-02)(p. 393)

2.2.6 Position controller

MANDATORY EASY 1 MIN

When installing the controller on the floor, secure at least 50 mm of space on each side of the controller to enable ventilation.

⚠ Caution

Ensure that the cables have curvatures greater than the minimum curvature radius. For more information, refer to [Routing of Manipulator Cable and Teach Pendant Cable](#)(p. 187).

2.2.7 Power-up controller

MANDATORY EASY 3 MIN

⚠ For more information about robot booting, refer to [Connecting External Device – DART Platform](#)(p. 217)

1. Press the power switch at the bottom of the controller. The system is powered up including robot, controller, teach pendant and smart pendant.

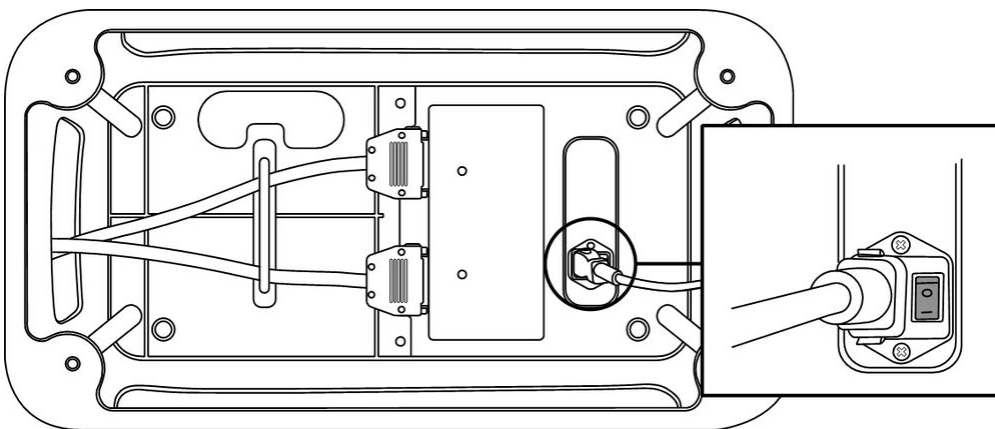

2. Press and hold the power button (Fig. 2) until the teach pendant screen powers up. The teach pendant LED (Fig. 1) and flange LED (Fig. 3) will blink red until the robot controller connects to the network.



- For more information about equipment other than the teach pendant, refer to [System Power On/Off\(p. 223\)](#) .

Note

LED positions of each Doosan Robotics robot series are as follows:

- A: Flange LED
- B: Axis 1 LED



2.2.8 Disengage emergency stop button

MANDATORY **EASY** 1 MIN

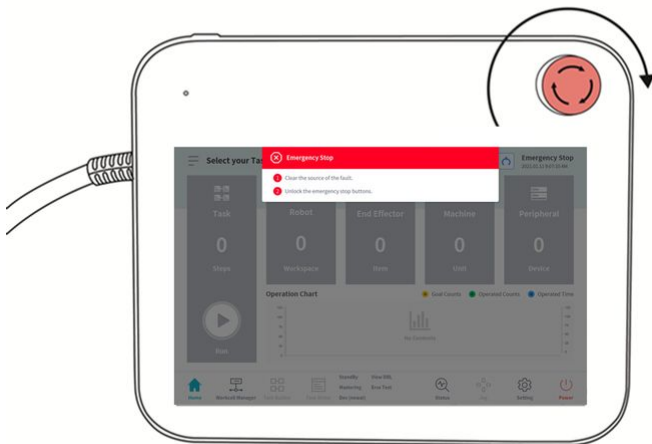

After robot installation and after the initial system boot up, a warning popup is displayed as the emergency stop button of the teach pendant is pressed. The emergency stop button must be disengaged in order to operate the robot.

- Twist the emergency stop button clockwise to disengage the emergency stop state.

2.2.9 Disengage packaging pose

MANDATORY **EASY** 3 MIN

The robot is in its packaging pose to allow easy transportation or packaging. To use the robot, it is necessary to disengage the packaging pose. As the robot maintains a pose that exceeds the Joint Angle Limit when in packaging pose, it is impossible to set Servo On status due to safety limit violation. The robot LED is illuminated red in this state.

Note

If there is a case in which you need to package the robot due to relocating, set the package pose by using move with packaging pose in the packaging mode.

The process of releasing the packaging pose is as follows:

1. Tap **status** on the initial screen of the teach pendant.

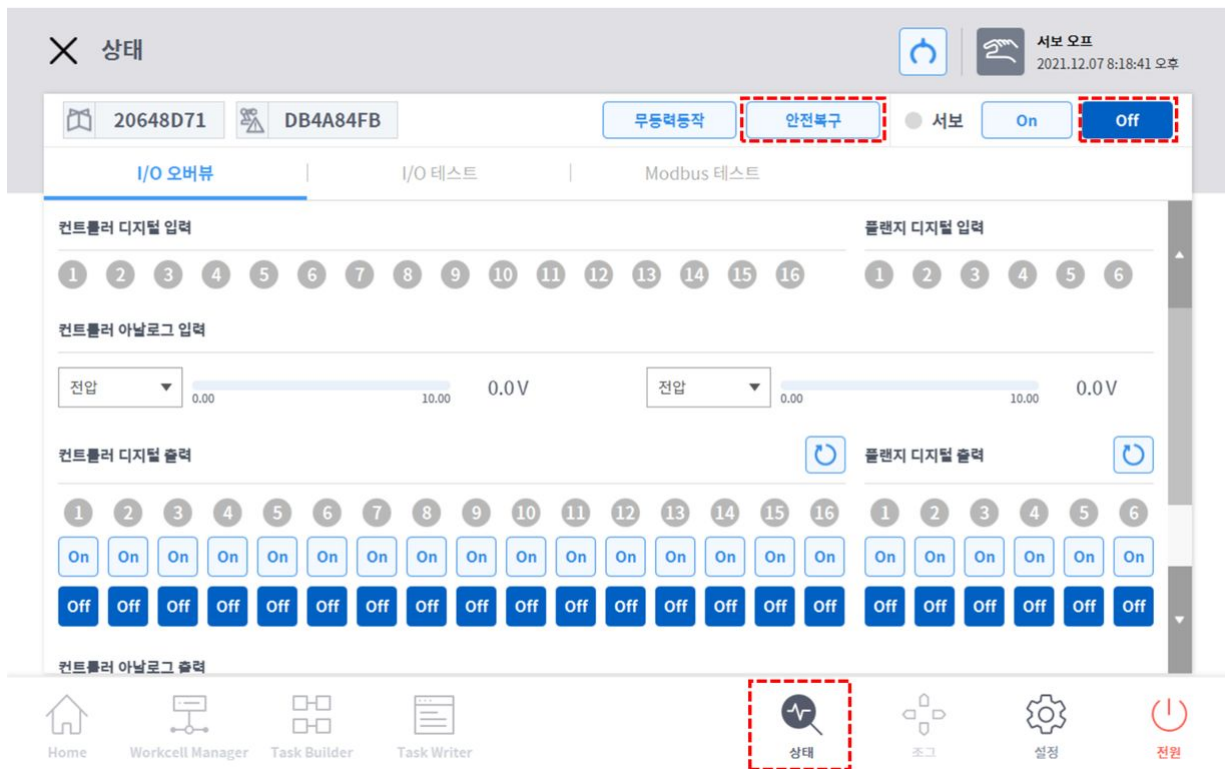

2. Tap the **Safety Recovery** button. The **Safety Recovery** button is enabled when in **Servo Off** status.

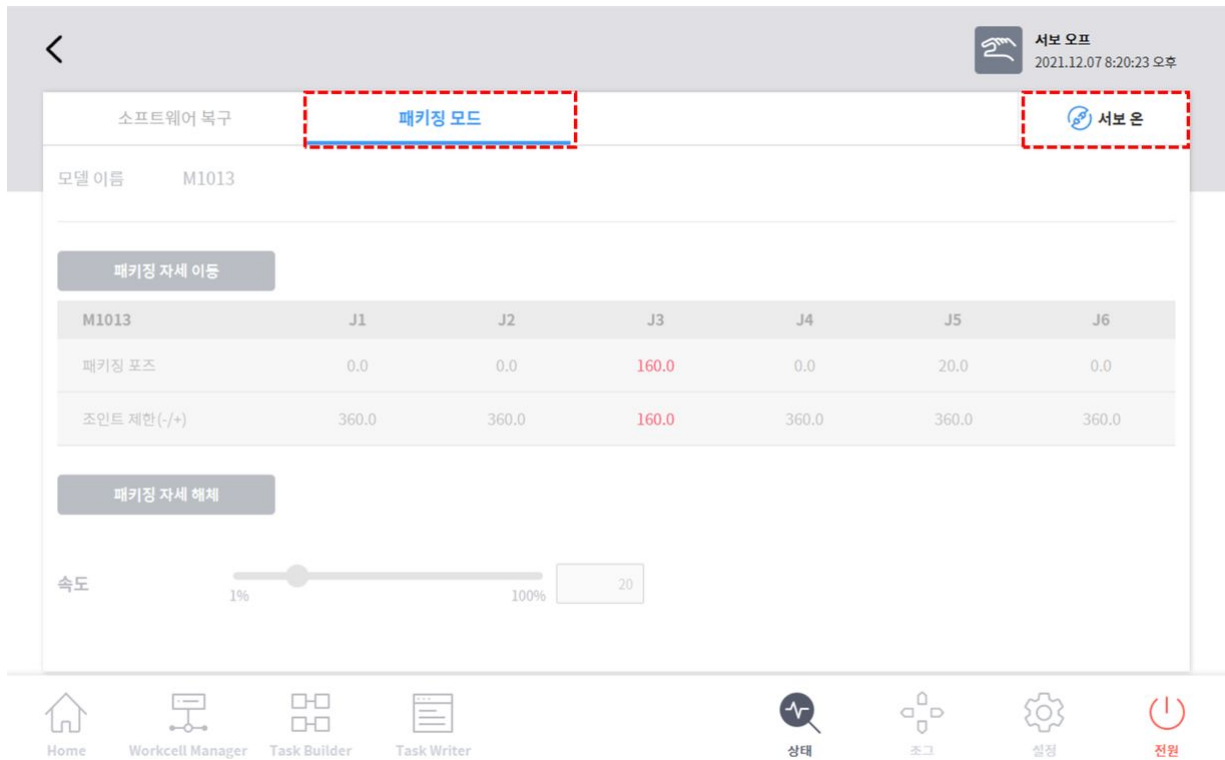

3. Select the **Packaging Mode** tab.

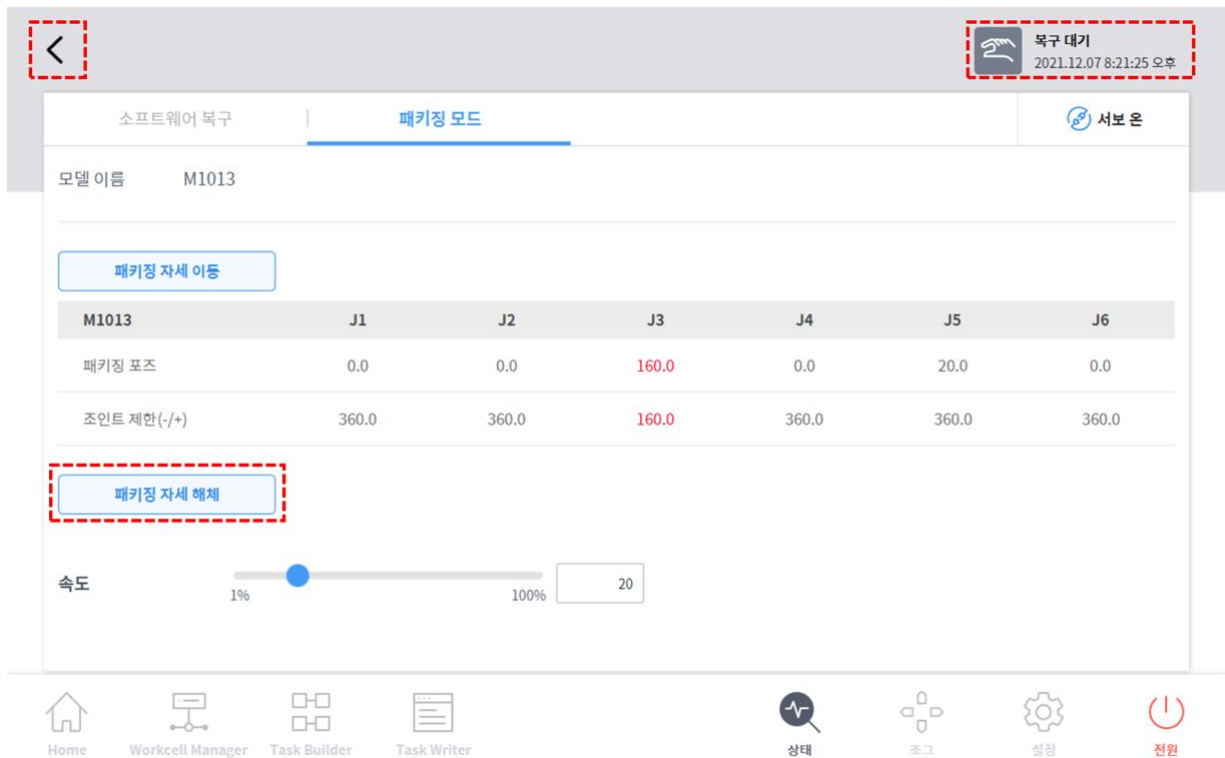

4. Tap the **Servo On** button.

5. The robot status display on the bottom right of the teach pendant screen changes from **Safety Off** to **Recovery Standby**. Tap the **Packaging Mode** toggle button on the **Packaging Mode** tab.



6. **Press and hold the Disengage Packaging Pose** button. The robot's packaging mode is disengaged, and the robot moves to the home position. When the robot is in the home position, it does not move any further.
7. After the robot is in the home position, tap the  button on the top left of the screen.
8. The robot status display on the bottom right of the teach pendant changes from **Recovery Standby to Manual Standby**. The robot is now in a state where the user can operate it. Press the  **Close** button on the **Status** screen to close the status window.



2.2.10 Servo Off

MANDATORY EASY 1 MIN

Servo on status is the status where the robot is ready with power supplied to robot joints to modify the robot pose.

Press Servo Off button to cut off power supplied to the robot joints and stop the robot. For more information, refer to [Servo On](#)(p. 240).



2.3 Step 2. Tool Installation and I/O Testing

In this step, you can learn how to install a tool on the flange at the end of the robot and how to perform the I/O test.

2.3.1 Installing the tool

MANDATORY EASY 5 MIN

Use four M6 bolts to secure the tool on the tool flange.

- It is recommended to use tightening torque of 9 Nm to tighten the bolts.

- Use a $\Phi 6$ place marker pin to accurately install the robot in a fixed location.

Note

- For more information about the tool flange, refer to [Connecting the Robot and Tool](#)(p. 190).
- Methods of securing the tool may vary according to the tool. For more information about tool installation, refer to the manual provided by the tool manufacturer.

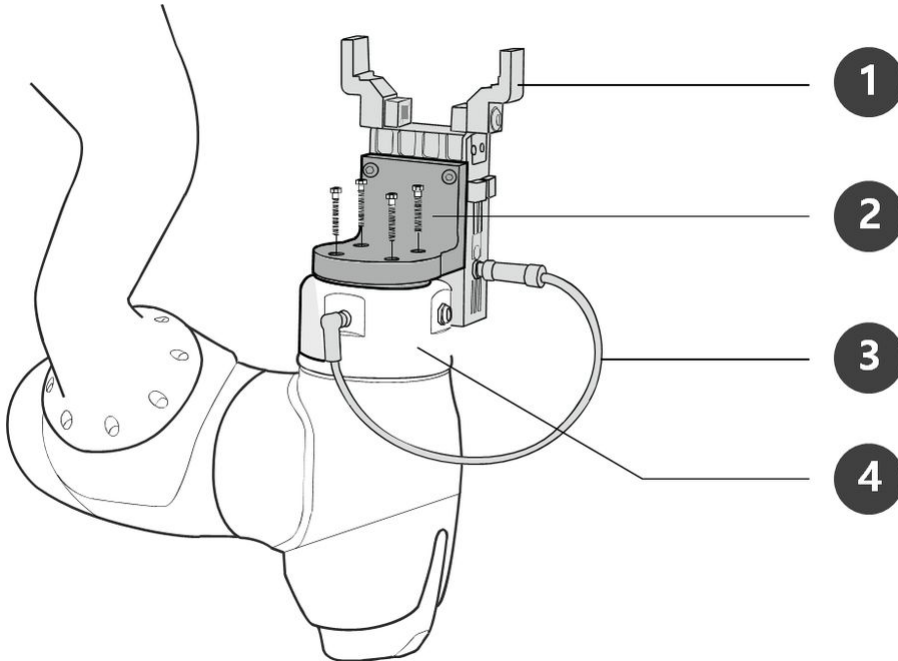

No.	Item
1	Tool
2	Bracket
3	Cable
4	Tool Flange

2.3.2 Turn system power off

MANDATORY **EASY** 1 MIN

Press the shutdown button on the teach pendant or press and hold the power button on the upper left of the teach pendant for 2 seconds to turn off the system.

1. The shutdown popup is displayed on the screen.
2. Press the OK button on the shutdown popup to properly shutdown the system.

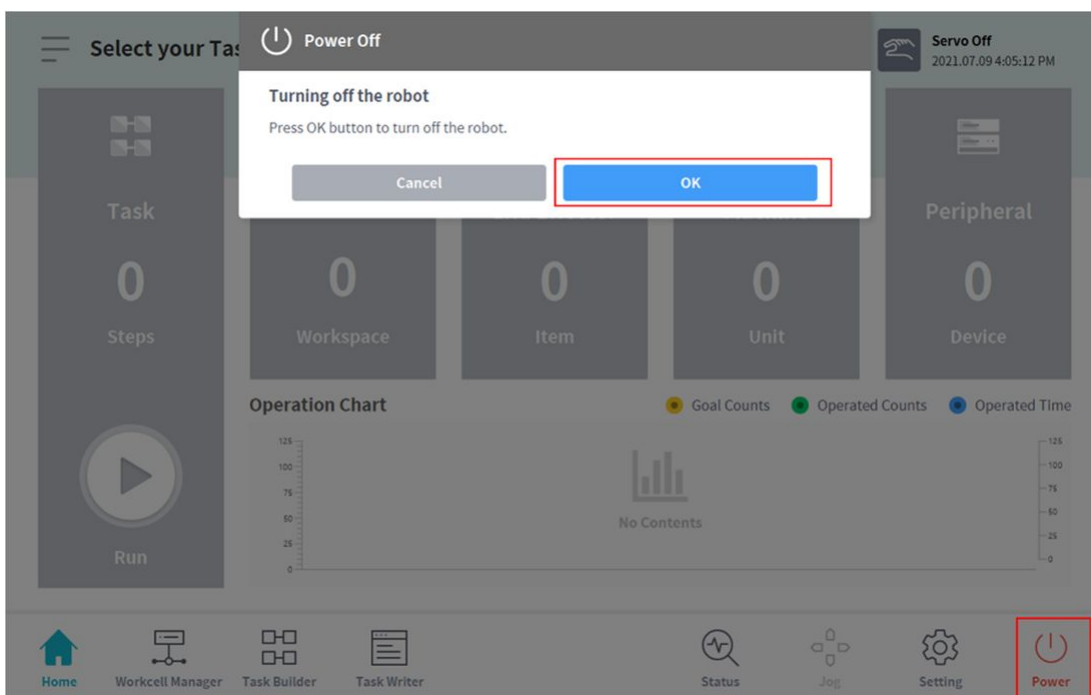
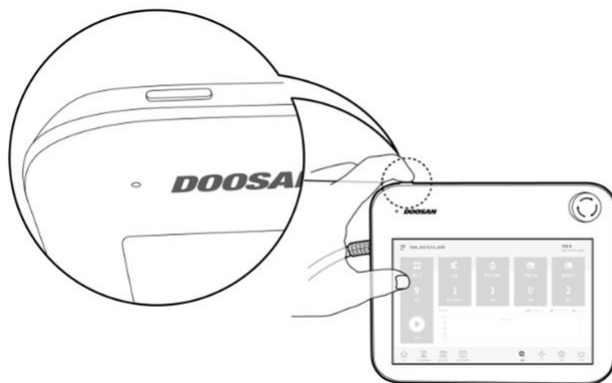

⚠ Caution

- Press and hold the power button for more than 4 seconds to force system shutdown.
- Forced shutdown may cause robot and controller failure.

2.3.3 Connect wires

MANDATORY **NORMAL** 10 MIN

Connect the necessary cables to the flange I/O connectors after the tool is secured. The pin map of the flange I/O must be checked.

- When power is supplied to the robot, the fifth terminal of each connector always outputs 24V.
- For more information, refer to [Flange I/O](#)(p. 193).

⚠ Caution

- Make sure to cut off the robot's power when connecting the tool and gripper.
- Make sure to configure tool and gripper measures to prevent workpieces falling from the tool when the robot power is cut off.

ℹ Note

To control/monitor the robot using an external device, connect the controller I/O or connect to a network, such as Modbus TCP, PROFITNET or EtherNet/IP.

- For more information, refer to [Connecting Controller I/O](#)(p. 200).
- For more information, refer to [Network Connection](#)(p. 215).

2.3.4 Turn system power on

MANDATORY **EASY** 1 MIN

Turn the system power on again. Press and hold the power button until the teach pendant screen powers up.

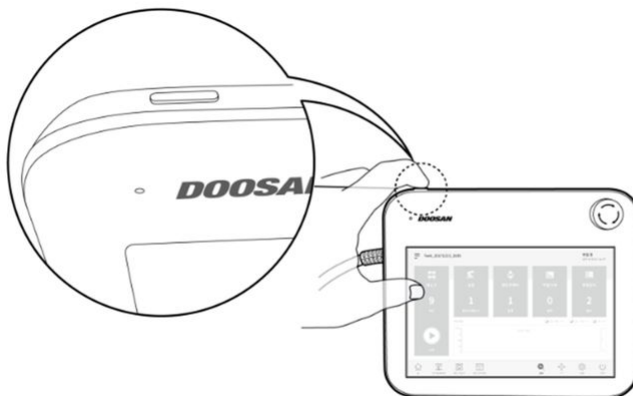

2.3.5 Test controller and flange I/O

MANDATORY **NORMAL** 10 MIN

The teach pendant features a function capable of testing the operation of the tool connected to the flange I/O.

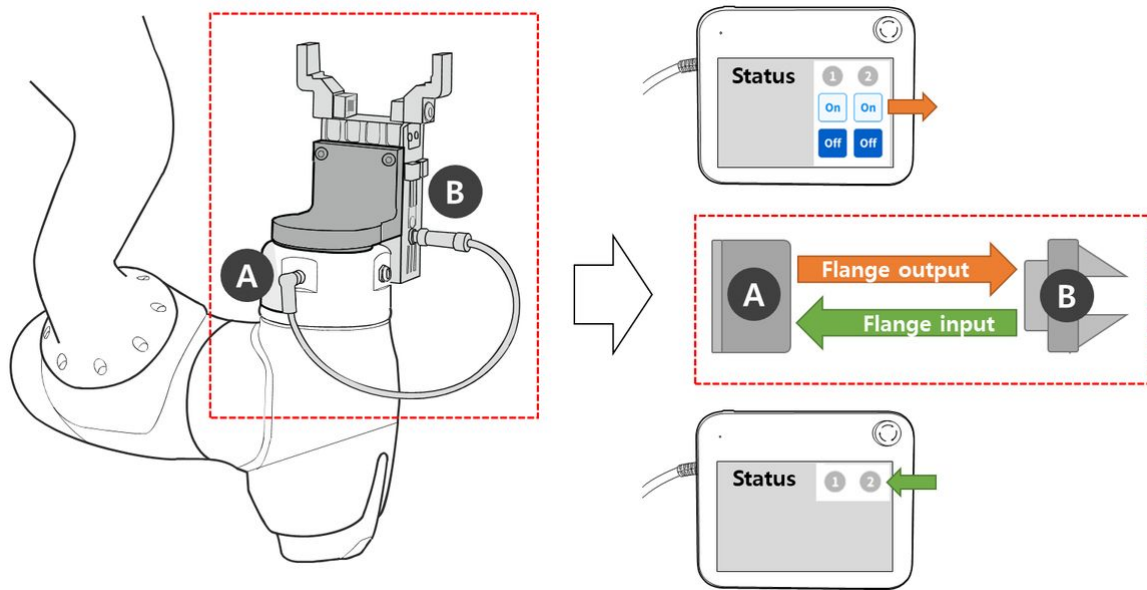

The following tests can be performed through **Status > I/O Overview** or **I/O Test** of the teach pendant screen. For more information, refer to each item.

- [Controller/Flange Digital Input Check](#)(p. 241)
- [Controller/Flange Analog Input Check](#)(p. 241)
- [Controller/Flange Digital Output Setting](#)(p. 242)
- [Controller/Flange Analog Output Setting](#)(p. 243)

2.4 Step 3. Robot Operation and Setting

In this step, you can learn how to operate the robot manually and how to set and add Workcell Items of the robot.

⚠ Caution

- Before operating the robot, make sure to read and follow [General Instructions](#)(p. 10) and [Precautions for Use](#)(p. 11).
- For more information about using the robot safely, refer to [PART 1. Safety Manual](#)(p. 9).
- For more information about robot operation and setting, refer to [PART 4. User Manual](#)(p. 223).

ℹ Note

Doosan Robotics robot offers the following convenience functions: These functions automatically calculate values which the user otherwise would have to calculate and enter manually.

1. **Auto Tool Weight Measurement:** The weight and center of gravity of the tool installed on the robot end are calculated automatically through a series of robot motions.
2. **Auto Mount Measurement:** The mount of surface on which the robot is installed is automatically calculated through a series of robot motions.

3. **Auto Tool Center Point (TCP) Measurement:** The position of the tool installed on the robot end is automatically calculated.

2.4.1 Learn how to engage/disengage Safety Stop

MANDATORY **EASY** 5 MIN

Learn the types of safety stops and how to engage/disengage safety stop.

Types of Safety Stops

The stop modes provided to ensure user safety are as follows:

- STO (Safe Torque Off): Stops Servo Off (motor power is immediately turned off)
- SS1 (Safe Stop 1): Servo Off after maximum deceleration stop
- SS2 (Safe Stop 2): Standby after maximum deceleration stop (pause)
- RS1: Upon collision, complies to the direction opposite of the collision and then enters standby (can only be set in Collision Detection/TCP Force Limit Violation)

Doosan Robotics robots have two types of safety stop functions. Emergency Stop is used for general emergency situations, and the robot can resume operation with Servo On after releasing the emergency stop. In case of Protective Stop, the robot can resume operation by resolving the cause of Protective Stop and releasing the stop.

- Emergency Stop: It sets the stop mode when the Emergency Stop button of the teach pendant or an additionally installed external device is activated
 - It activates when the Emergency Stop switch of the teach pendant or the one connected to the TBSFT EM terminal is pressed.
 - Only STO or SS1 can be selected.
- Protective Stop: It sets the stop mode when the externally connected protective equipment is activated
 - It activates when the protective equipment connected to the TBSFT PR terminal is activated.

For more information about the Safety Stop functions, refer to [Safety Function](#)(p. 21).

How to engage/disengage Safety Stop

Press the Emergency Stop button on the teach pendant or activate the safety device connected to the Safety I/O to activate emergency stop. Safety devices can be connected to Emergency Stop or Protective Stop through **Workcell Manager > Robot > Safety I/O** functions of the teach pendant screen.

- For more information about connecting a safety device to Safety I/O, refer to [Connecting Controller I/O](#)(p. 200).
- For more information about how to set the Safety Stop function from the program, refer to [Safety I/O Setting](#)(p. 260).

2.4.2 Manual Operation - Learn how to perform safety recovery/powerless motion

MANDATORY NORMAL 15 MIN



Sorry, the widget is not supported in this export.
But you can reach it using the following URL:

<https://www.youtube.com/watch?v=-5SUad8y6ig>

These two recovery modes are used to move the robot to the Safety Zone in Servo Off status when the Emergency Stop is activated or the robot does not operate properly due to collision, etc. Set Servo Off to activate safety recovery or powerless motion mode. For more information, refer to [Safety Recovery Mode](#)(p. 305) and [Backdrive Mode](#)(p. 307).

- Safety Recovery: It is used when modifying the robot pose in Servo Off status.
 - Software Safety Recovery: It is the most commonly used recovery function and is used to manually operate and to move the robot to the Safety Zone through direct teaching or manual job operation when the robot stopped due to safety and space zone limit violation.
 - Packaging Mode: It is the function only used during the initial delivery and is used to release the robot from its packaging pose or set it to its packaging pose.
- Powerless Motion: It is the function used when the robot does not operate properly or is in a dangerous situation, which allows the robot to be moved to the Safety Zone by pushing or pulling it by hand.

2.4.3 Manual Operation - Learn how to use jog

MANDATORY NORMAL 15 MIN

The user can select a manual movement method from the Jog tab. For more information about the jog/move/align, refer to [Jog Function](#)(p. 288).

- **Jog:** It moves the robot joint or TCP to the joint axis or coordinate axis the user selected
- **Move:** It moves the robot joint or TCP to the target point the user entered
- **Align:** It moves the robot end to the plane perpendicular to the user-selected plane and coordinate axis parallel to the robot end

Robot movement consists of two types.

1. Joint Motion: It moves each joint linearly with a rotating motion
2. Task Motion: It moves the end linearly to the target point

The following is the method how to move the robot using joint motion from the jog screen:

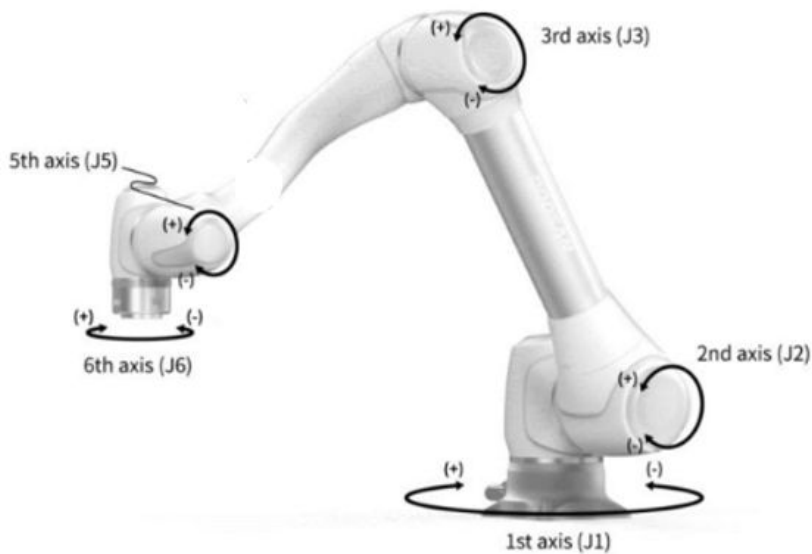

1. Select the Joint tab.
2. Select the axis to move. For example, You can select J1.
3. Press the +/- button to move the robot. The robot moves while the +/- button is pressed, and the current location is displayed on the screen in real-time.

The following is the method how to move the robot using task motion on the jog screen:

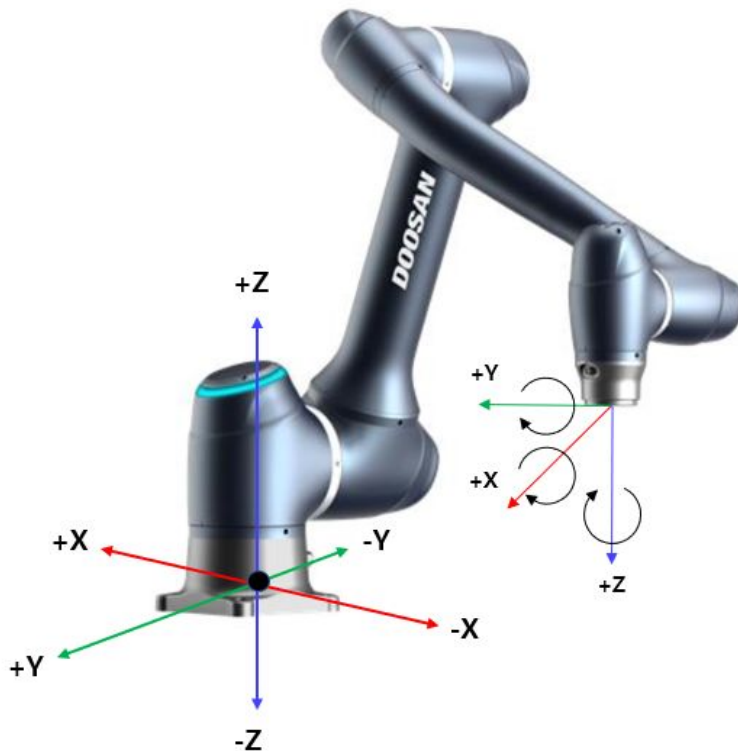

1. Select the base coordinates. The robot can be moved according to the BASE coordinates or the TOOL coordinates.
2. Select the direction to move. For example, X-axis can be selected.
3. Press the +/- button to move the robot. The robot moves while the +/- button is pressed, and the current location is displayed on the screen in real-time.

For more information about jog movement, move and align, refer to [Jog Screen\(p. 296\)](#), [Movement Screen\(p. 301\)](#) and [Align Screen\(p. 289\)](#) respectively.

Note

If the toggle switch of the actual mode on the top left of the Jog screen is turned off, the robot moves only on the virtual screen on the left of the Jog screen. The actual robot moves if the actual mode toggle switch is turned on.

2.4.4 Manual Operation - Learn how to perform direct teaching

MANDATORY EASY 5 MIN

Direct teaching is used to hold the robot end with one's hands to push and pull the robot to the desired pose, and apply the pose to the currently selected motion. There are two direct teaching methods.

- Freedrive: Each joint moves in the direction the user applied force
- Constrained Motion: The robot end moves or rotates only in the direction set in the constrained motion even when force is applied from a random direction

Freedrive

When Button 1 is pressed, the Freedrive mode is activated, allowing the robot to be moved freely. Each joint moves in the direction the user applied force. The robot cannot be moved by hand once the button is released.

- During direct teaching, the robot LED blinks cyan.

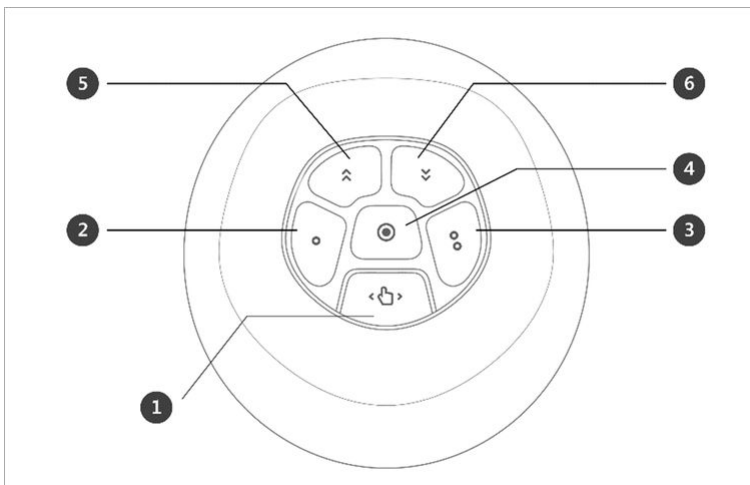

Pressing the hand guide button on the back of the teach pendant will activate the Freedrive mode, just like pressing Button 1, and the robot can be moved freely.

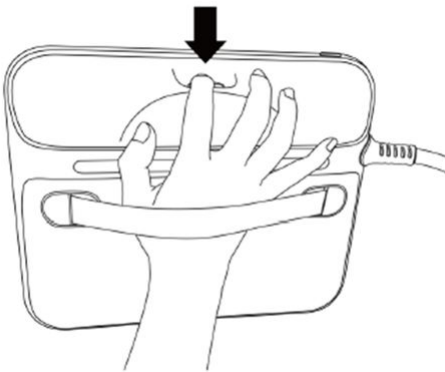

For more information about each button function, refer to [Hand-Guiding Operation](#)(p. 309).

Constrained Motion

When Button 2 and Button 3 are pressed, the robot end moves only in the direction matching the constraint condition even when force is applied from a random direction. The constraint condition can be set with 2 of 4 of the conditions in the following figure: Z-axis constrained, plane fix constrained, surface constrained and direction constrained.

2.4.5 Disengage the Password Lock

MANDATORY EASY 1 MIN

When changing various settings after robot installation, the process can be troublesome as the system constantly requests the password to be entered.

In this case, enter the password through **Setting > Safety Password**. If the system requests the password when the password is not changed, enter the following password.

- admin

Touch the Password Lock toggle switch to disable the Password Lock function. Then all password lock functions will be disabled until the controller is rebooted.



 **Caution**

Once the administrator finishes setting up the system, the password lock function must be enabled again before the user starts operating the system.



2.4.6 Robot Setting - Set robot limits

MANDATORY EASY 5 MIN





Sorry, the widget is not supported in this export.

But you can reach it using the following URL:

<https://www.youtube.com/watch?v=Rtt1JgSdC6A>

In Robot Limits, various limits related to the robot can be set. These limits are used to ensure the robot operates safely within the set limits.

Robot limits can be set through **Workcell Manager > Robot Limits**.

- For more information about each limit, refer to [Robot Limits](#)(p. 31).
- For more information about setting and screen descriptions of limits, refer to [Robot Limits Setting](#)(p. 273).

2.4.7 Workcell Item - Add robot installation pose (Mount)

OPTIONAL EASY 3 MIN

The robot installation pose can be set by adding a robot installation pose (mount) Workcell Item. If the robot is installed on a flat surface, this step can be skipped.

Robot installation pose can be set through **Workcell Manager > Robot > + > Robot > Mount**. For more information, refer to [Mount Setting](#)(p. 278).

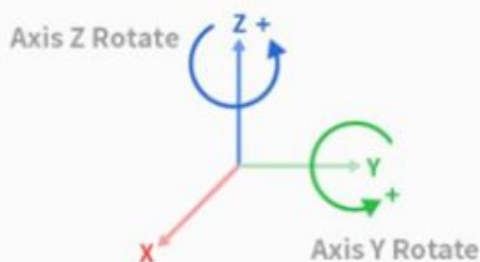

- The installation angle can be measured using the auto measure function. However, if the angle is less than 5 degrees, auto measure is unavailable.
- If the robot is installed on the ceiling or wall, the robot installation angle can be set with Y-axis and Z-axis rotations.
- As auto tool weight calculation is performed based on gravity, it is recommended to reset the tool weight once mount setting is done.

Once the Workcell Item is registered (confirmed), the toggle switch must be enabled in order to use the Workcell Item.

Caution

When setting the robot installation pose (mount) Workcell Item, it is recommended to change the world coordinates as well. If the world coordinates are not changed, the robot pose on the robot simulator screen of the teach pendant is displayed as the robot being installed on the flat surface (basic).

2.4.8 Workcell Item - Add Tool Weight

MANDATORY EASY 5 MIN

The weight of the tool installed on the flange can be set by adding a tool weight Workcell Item. Tool weight can be set through **Workcell Manager > Robot > + > Robot > Tool Weight**. For more information, refer to [Tool Weight Setting](#)(p. 276).

- The tool weight can be measured using the auto measure function.
- It is recommended to add tool weight as Workcell Items for each tool with a workpiece. If the workpiece weight is too heavy, the robot may recognize the weight of the workpiece as external force. It is because the robot determines this external force as a collision and stops.
- When creating a task, change the weight Workcell Item according to the process to change the tool weight. For example, it is possible to configure a task to select the standard tool weight Workcell Item before picking up a workpiece, and select the tool weight Workcell Item with the workpiece after picking up a workpiece.

Once the Workcell Item is registered (confirmed), the toggle switch must be enabled in order to use the Workcell Item. The activated tool weight Workcell Item can be set as the standard tool weight by pressing the set tool icon () on the top of the teach pendant.

- Set of the tool setting is the same as **set** of Other Commands. **Set** command can be used when changing the Tool Weight while a task is being performed. For more information, refer to [Task Builder Commands](#)(p. 323) and [Task Writer Command](#)(p. 348).



Note

Up to fifty different tool weights can be registered.

2.4.9 Workcell Item - Add Tool Shape

MANDATORY EASY 5 MIN

The shape of the tool installed on the flange can be set by adding a tool shape Workcell Item.

Too shape can be set through **Workcell Manager > Robot > + > Robot > Tool Shape**. For more information, refer to [Tool Shape Setting](#)(p. 254).

- The robot determines space limit violation status based on the TCP (Tool Center Point) of the robot end and the robot body. If the actual robot has a tool shape larger than the set TCP, a tool shape Workcell Item must be added to protect the workpiece and tool.
- Take caution as the zone the robot can maneuver will decrease if the tool shape is set too large.

Once the Workcell Item is registered (confirmed), the toggle switch must be enabled in order to use the Workcell Item. The activated tool shape Workcell Item can be set as the standard tool shape by pressing the set tool icon (🔗) on the top of the teach pendant.

- Set of the tool setting is the same as **set** of Other Commands. **Set** command can be used when changing the Tool Shape while a task is being performed. For more information, refer to [Task Builder Commands](#)(p. 323) and [Task Writer Command](#)(p. 348).



Note

Up to fifty different tool shapes can be registered.

2.4.10 Workcell Item - Add End Effector

MANDATORY

NORMAL

10 MIN

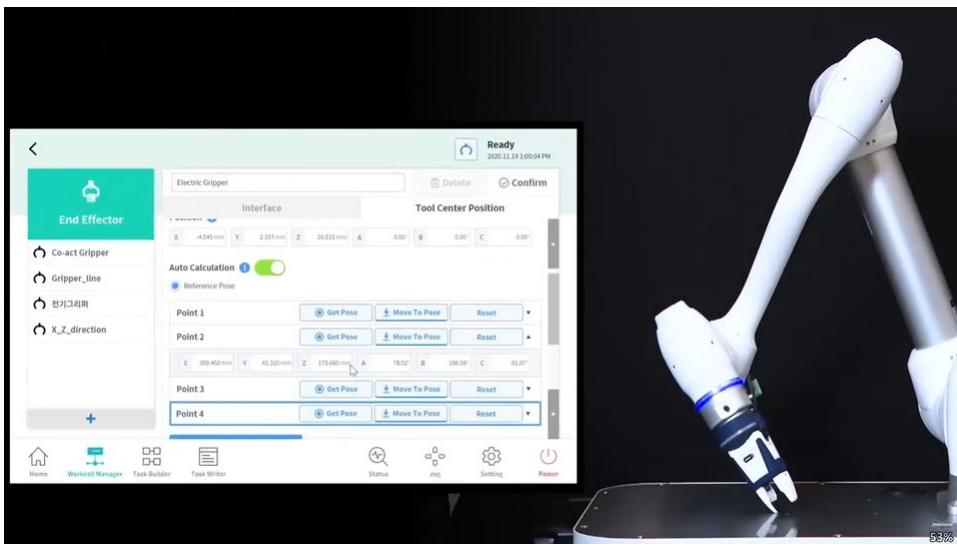

Sorry, the widget is not supported in this export.
But you can reach it using the following URL:

<https://www.youtube.com/watch?v=SLnt5F7Oisw>

The tool I/O, communication interface, and TCP (Tool Center Point) can be registered by adding an End Effector Workcell Item. The end effector consists of tools and grippers.

The end effector can be set through **Workcell Manager > End Effector > + > Gripper, Tools > ...** . For more information, refer to [End Effector Setting](#)(p. 279).

- Interface: It provides interface setting (analog/digital I/O, communication, etc.) and test functions for tools or grippers

- TCP (Tool Center Point): TCP means the center point of the tool, and the gripper's end point is generally set as the TCP

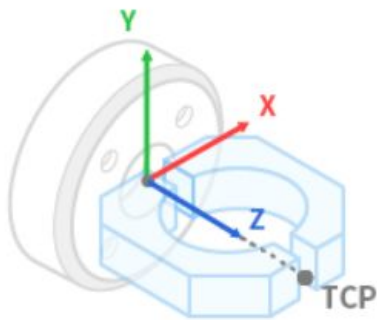

The offset values of the TCP tab can be calculated using the auto calculation function. The TCP offset can be calculated by moving the robot with 4 poses centering the TCP.

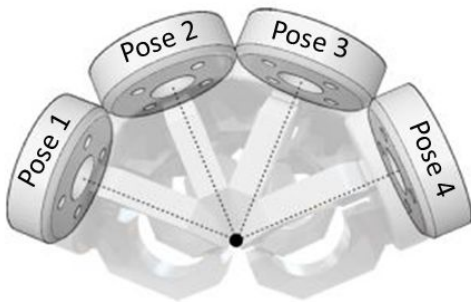

Once the Workcell Item is registered (confirmed), the toggle switch must be enabled in order to use the Workcell Item. The activated end effector Workcell Item can be set as the standard TCP (Tool Center Point) by pressing the set tool icon () on the top of the teach pendant.

- Set of the tool setting is the same as **set** of Other Commands. **Set** command can be used when changing the TCP while a task is being performed. For more information, refer to [Task Builder Commands](#)(p. 323) and [Task Writer Command](#)(p. 348).

Note

- Up to fifty different end effectors can be registered.
- The Task Builder activates skills based on preset Workcell Items, such as end effectors and peripherals. Processes, such as Pick & Place or Pallet Stocking, can be created conveniently with such skills.

2.4.11 Workcell Item - Add Space Limit

OPTIONAL **NORMAL** 10 MIN

The space limit Workcell Item sets a virtual boundary at the outermost zone of the robot. The robot can be operated without setting space limits, but it is recommended to set space limits to ensure safe operation of the robot.

Space limit can be set through **Workcell Manager** > **+** > **Space Limit** > **Cuboid, Cylinder, Multi-plane Box, Sphere or Tilted Cube**. For more information, refer to [Space Limit Settings](#)(p. 266).

- Inspection Point can be set as the robot or TCP, and the valid space can be set as interior or exterior.
- The monitoring zone can be set as robot or TCP. It sets whether to detect the interior or exterior zone or not.
- The default value is the entire zone and the set interior.
- The robot can be set properly after it is positioned in the set safety zone.

2.4.12 Robot Setting - Set World Coordinates

OPTIONAL NORMAL 3 MIN

The world coordinates of the robot can be set from World Coordinates. In case the robot coordinate is the base coordinates, this step can be skipped.

World coordinates can be set through **Workcell Manager** > **Robot** > **World Coordinates**. For more information, refer to [World Coordinates Setting](#)(p. 255).

- World coordinates are used when the robot base installation location is physically moved/rotated.
- Changing the world coordinates will apply the same move/rotation to the robot simulator screen.

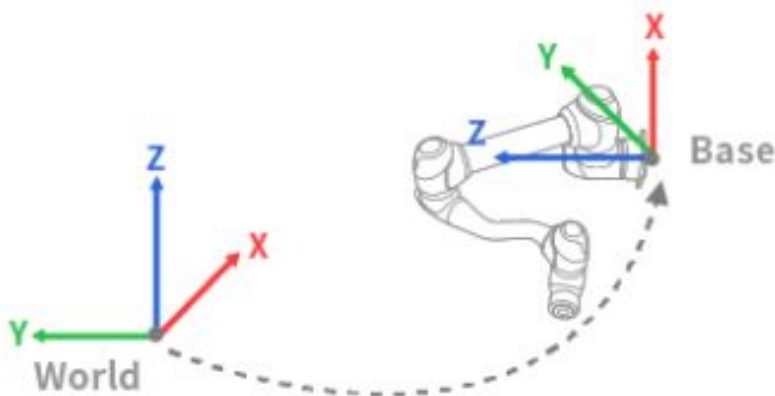

Note

World coordinates can also be used even after the base location and angle are changed after robot teaching. If the coordinates of tasks created through robot teaching in the past are changed from BASE to WORLD, an offset corresponding to the move/rotation of world coordinates is applied to all motion coordinates.

2.4.13 Learn about Workcell Manager and Workcell Item

MANDATORY EASY 5 MIN

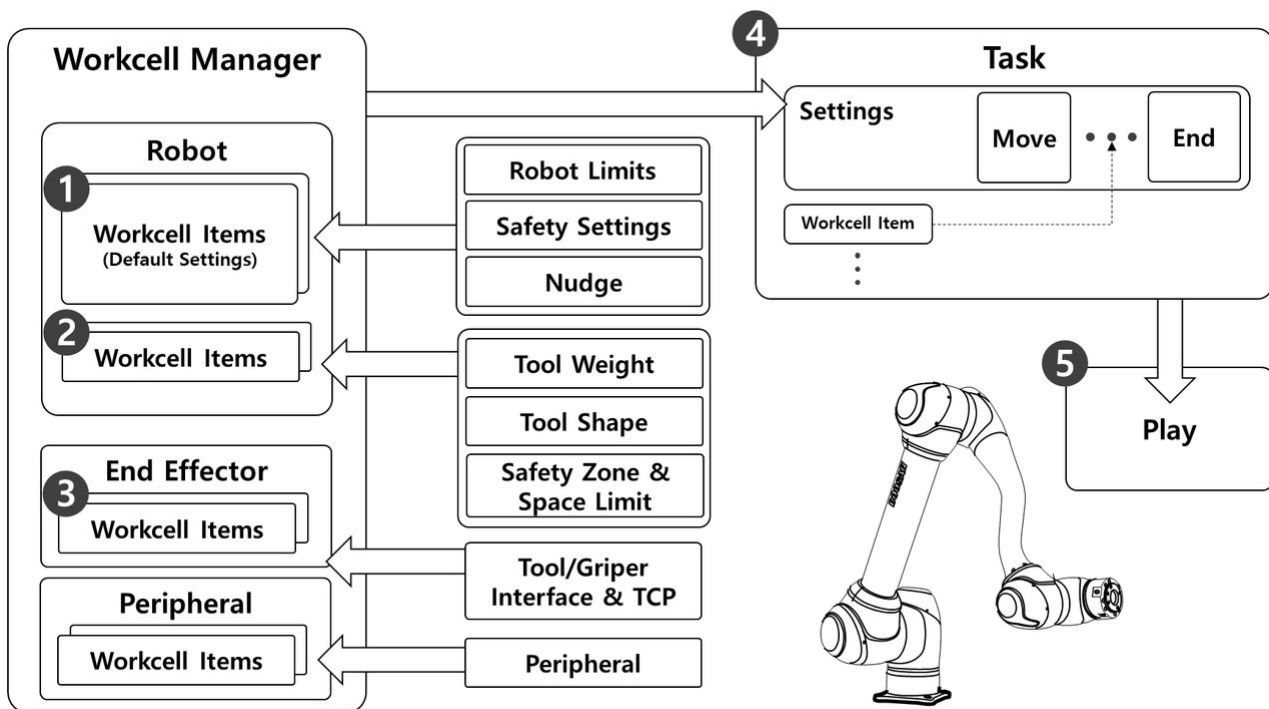

As shown in the figure above, the Workcell Manager manages robot settings, including coordinates, and safety settings, and Workcell Items, including tools, grippers and peripherals. Tool weight, tool shape, end effector TCP (Tool Center Point), machine and peripherals can be added to the Workcell Manager. Settings and Workcell Items added to the Workcell Manager are used when creating a Task which refers to the work the robot performs.

The process of creating a task and automatically operating the robot is as follows:

1. **Standard Workcell Item Setting:** The robot has standard Workcell Items such as robot limits and safety settings. These Workcell Items are set to ensure the safe operation of the robot.
2. **Add Workcell Item:** It registers tool shape and weight information, as well as Safety Zone and Space Limits as individual Workcell Items.
3. **Add End Effector:** As most robots have tools installed, it adds the I/O interface and TCP of the tool as a single end effector Workcell Item.
4. **Create Task:** Standard Workcell Item setting of the Workcell Manager is applied during task creation, and registered Workcell Items are used when necessary.
5. **Play Task:** It plays the task.

2.5 Step 4. Create Task Program

In this step, you can learn how to create a robot task program and how to test it.

Caution

- Before operating the robot, make sure to read and follow [General Instructions](#)(p. 10) and [Precautions for Use](#)(p. 11).
- For more information about using the robot safely, refer to [PART 1. Safety Manual](#)(p. 9).

- For more information about the task program, refer to [PART 4. User Manual\(p. 223\)](#).

2.5.1 Start programming

MANDATORY **EASY** 3 MIN

Caution

- Before programming, the safety setting, installation pose and tool setting must be completed with the Workcell Manager. For more information, refer to [Step 3. Robot Operation and Setting\(p. 108\)](#).
- Excessive use of TP_LOG or SET commands within loops may cause CPU overload.

Doosan Robotics offers two types of task programming environments.

- Task Builder: It is an icon block-based coding environment utilizing command and skill icons. Skills are supported based on Workcell Items registered on Workcell Manager.
- Task Writer: It is a block-based coding environment utilizing script-based programming for easy input to the teach pendant

The difference between the two programming environments is as follows: In general, novice users or users who wish to use skills use the Task Builder. Intermediate users who do not wish to use skills use the Task Writer for quick programming.

	Classification	Task Builder	Task Writer
1	Subjects	Novice users or users who need to use skills	Intermediate users
2	Block-based coding	O	O
3	Use of command icons	O	X
4	Skill support	O	X

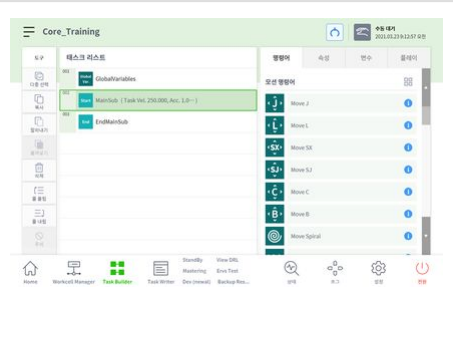
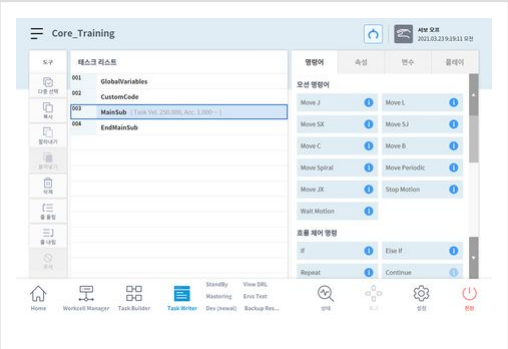
Classification	Task Builder	Task Writer
5 Screen		

Note

What is Skill of Doosan Robotics robots?

- It is a command which configures interface for easy use by bundling various commands required in a process with a single setting.
- It can only be used in the Task Builder, and each skill is displayed as a single block. For example, the Task Builder icon blocks for Pick skill and Place skill are as follows:



2.5.2 Understand compliance/force control

OPTIONAL **HARD** 20 MIN

Force Control and Compliance Control are functions controlling robot force. These functions also control performing motion movement and force control if a motion command is added. Compliance control and force control have the following differences:

1. Compliance control

- The robot complies with external force at the robot end TCP during compliance control, and when the external force is removed, a force that returns the robot to its original position is created, causing the robot to move to the corresponding position.
- It can be used when linear motion is required on an uneven surface without damaging the robot and surface. It can be used to prevent unexpected collisions around the workpiece.

2. Force control

- During force control, force is generated at the robot end TCP. Acceleration is generated in the direction the force is generated, so the robot moves towards the motion direction as well as the force direction at the same time.
- When contact is made with an object, force will be applied on the object until the set force and the repelling force of the object form a balance.

- It can be used when equal force needs to be applied on a linear motion on an uneven surface. It can be used in tasks which require constant force while moving, such as polishing.

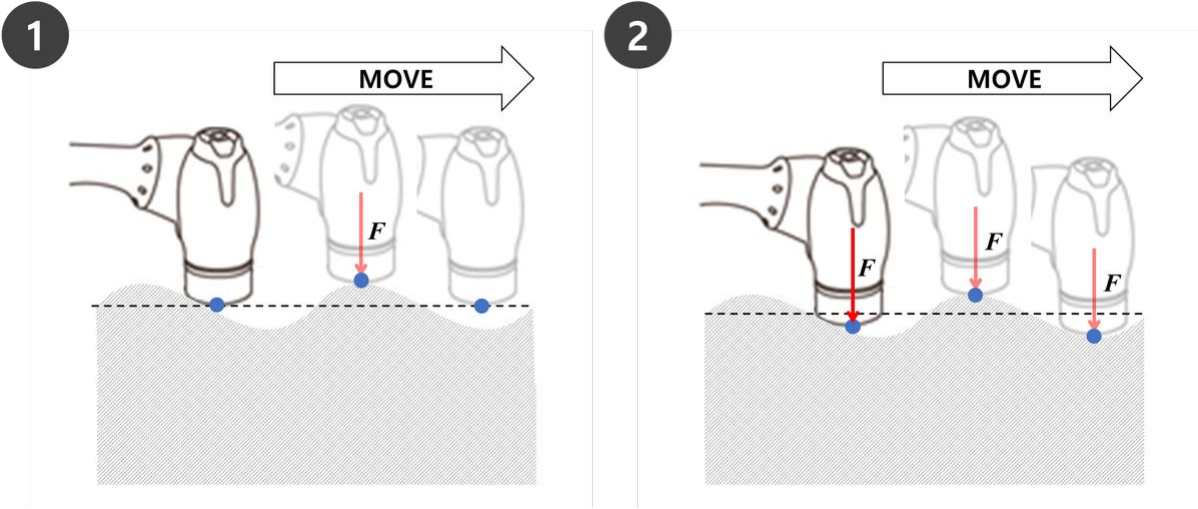

⚠ Caution
Compliance/force control may be affected by singularities, which can cause vibrations. Please be cautious and avoid using it near singularities.

i Note
Compliance and Force Commands are executed based on the current coordinates. The default coordinate of a task is the Base coordinates, and the coordinates can be changed with the Set command.

1. Fig. 1 is the operating direction when force/compliance control in the +Z direction is applied on the base coordinates.
2. Fig. 2 is the operating direction when force/compliance control in the +Z direction is applied on the tool coordinates.

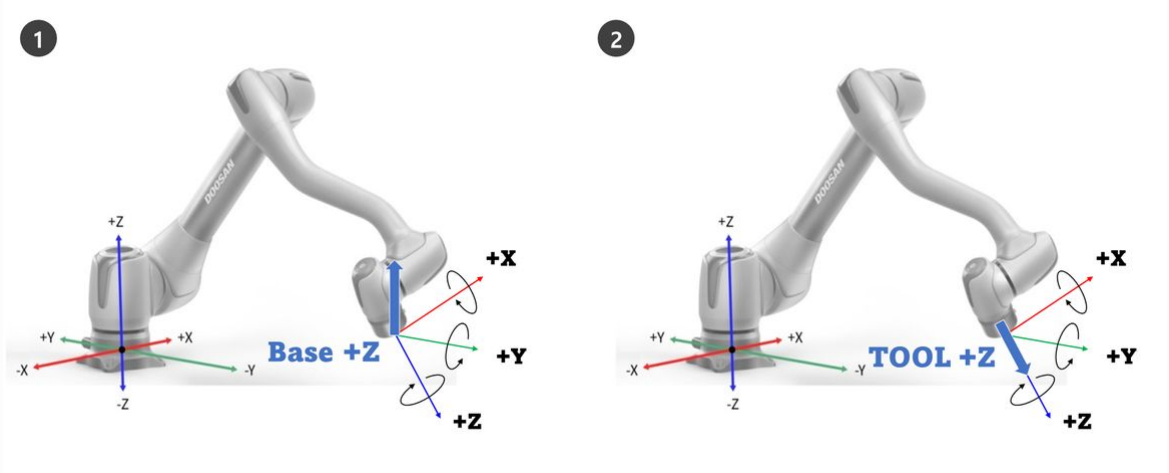

Compliance Control

Compliance control is the function that complies to external force according to the set stiffness when force is applied on the robot end TCP. It balances forces at the target point, and it is a control method that generates repelling force if displacement occurs away from the balancing point. During compliance control, the robot end bounces like a spring.

1. If collision is made when motion control is used alone, it is possible that the collided object may get damaged.
 - Doosan Robotics robots stop safely when a collision occurs, but depending on the user setting, such as **Safety Limits > Collision Sensitivity**, the following situations may occur.
2. If compliance control is set to on during motion control, the robot will move while complying to the collided object.

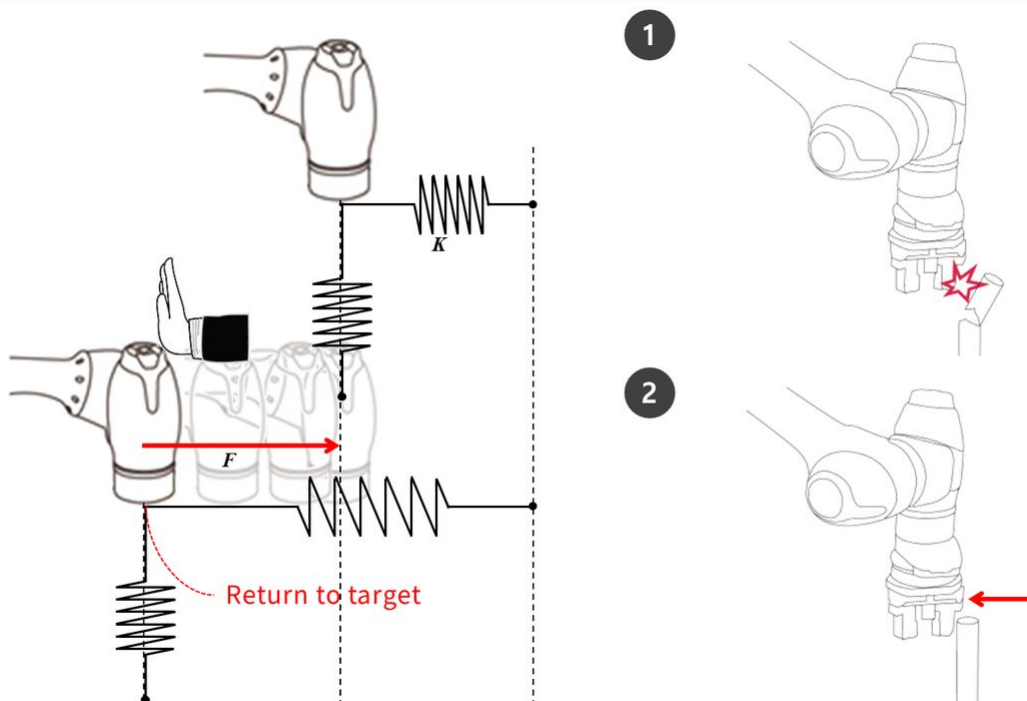

If F is external force, K is stiffness and X is distance, the following formulas are true.

- $F = K * X$
- $K = F / X$
- $X = F / K$

Based on the above formulas, if the stiffness of compliance control is set to 1000N/m and if the robot moves 1 mm, the external force generated is 1N.

- $F=1000 \text{ N/m} \times 0.001 \text{ m}=1 \text{ N}$ ($0.001 \text{ m}=1 \text{ mm}$)

Note
On the Property of Compliance Command, the following values can be set:

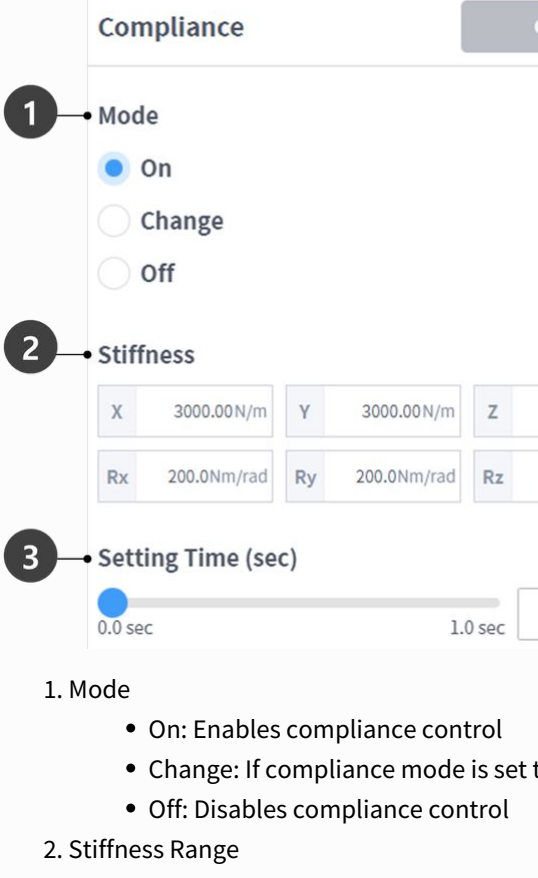

- 1. Mode**
 - On: Enables compliance control
 - Change: If compliance mode is set to On, it changes to stiffness
 - Off: Disables compliance control
- 2. Stiffness Range**
 - M/H Series : Translation(0~20000N/m), Rotation(0~1000Nm/rad)
 - A Series : Translation(0~10000N/m), Rotation(0~300Nm/rad)
 - Lower stiffness values will respond to external force more gently and will require more time to return to the target point
- 3. Setting Time**
 - It is the time required for the current stiffness value to reach the set stiffness value (0-1s)

Caution

- Tool weight and TCP (Tool Center Point) must be accurately set. Inaccurate tool weight can cause the robot to detect the tool weight as external force, and setting the Compliance Command On will generate position error.
- Tension of the dress pack may generate external torque on the robot. Therefore, take caution when installing the dress pack.
- Compliance cannot be turned on or off while async motion or blending motion is being executed.

- During Compliance Command on, only linear motion is allowed. Joint motions, such as MoveJ and MoveSJ, are not allowed.
- During Compliance Command On, Tool Weight or TCP cannot be changed.
- During Compliance Command on, it is possible to not accurately reach the target point due to compliance of the torque generated during motion execution. Therefore, it is recommended to turn on compliance control near the target point. Or, it is possible to minimize position error by setting a large stiffness value.

Force Control

Force Control is a function that applies force in the force control direction until the set force and repelling force form a balance

- It moves the robot in the set force direction, and if contact with an object is made, it maintains the entered force (N)
- It is capable of motion control in a direction different from the force direction while applying a constant force
- The minimum setting is +/- 10N, and it can be fine-tuned with a resolution of 0.2N
- Force Control is unavailable in singularity zone
- In general, Compliance Control is used in conjunction with force control so that force control complies to external force

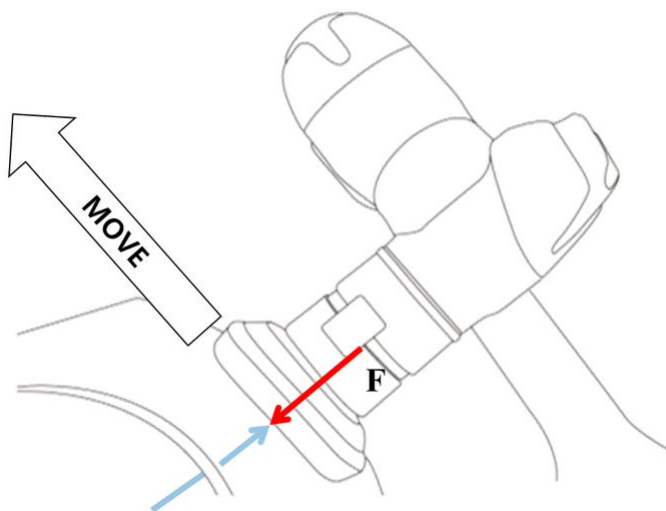

Note

From the property of Force Command, the following values can be set.

Force
Confirm

Specify the operation condition for the force control.

Mode

On
 Off

Desired Force

X	0.00 N	Y	0.00 N	Z	0.00 N
A	0.00 Nm	B	0.00 Nm	C	0.00 Nm

Target Direction

X
 Y
 Z
 A
 B
 C

Relative Mode i

Setting Time (sec)

0.0

0.0 sec 1.0 sec

1. Mode

- On: Enables Force Control
- Off: Disables Force Control

2. Desired Force Range

- X, Y, Z: 10 - (each robot's maximum) N
- A, B, C: 5 - (each robot's maximum) Nm
- For more information about maximum force, refer to [Upper/Lower Threshold Range and Default Value of Safety Parameters](#)(p. 84).

3. Target Direction

- It moves to the selected target value of each direction.
- Multiple selections can be made.
- Force control can only be executed with direction setting after force setting.
- If one of the multiple selected directions reaches the target force, it will continue to move until the target value is reached for the other direction.

4. Relative Mode

- If this mode is enabled, it calibrates the external force applied on the robot to 0 to improve the force control accuracy.
 - i. When relative mode is disabled, the actual force applying on the target is equal to the sum of the set force and external force.

ii. When relative mode is enabled, the actual force applying on the target is equal to the set force.

- During force control, deviation can occur depending on the pose or external force.
- During force control, it is possible not to reach the exact target point. Therefore, it is recommended to enable force control near the target point.

5. Setting Time

- It is the time required for the current force value to reach the set force value (0-1s).

2.5.3 Utilize Sub/Call Sub

OPTIONAL NORMAL 5 MIN

Sub is an abbreviation of Subroutine. A subroutine refers to a process that minimizes the number of steps in a program by calling necessary parts when two or more duplicate parts are present.

- Doosan Robotics robots provide a CallSub command to call Sub commands and the corresponding Sub paragraph.
- The Sub command functions as defined in Python.

Note

- Sub paragraph must be added in MainSub, the start of a Main paragraph, and EndMainSub, the end of a Main paragraph.
- In addition to repetition, the Sub command is also used to simplify a Main paragraph. Utilizing a Sub command will allow intuitive identification of what task of a Main paragraph is being performed at the moment.
- Utilizing a Sub command allows Sub paragraph unit testing.

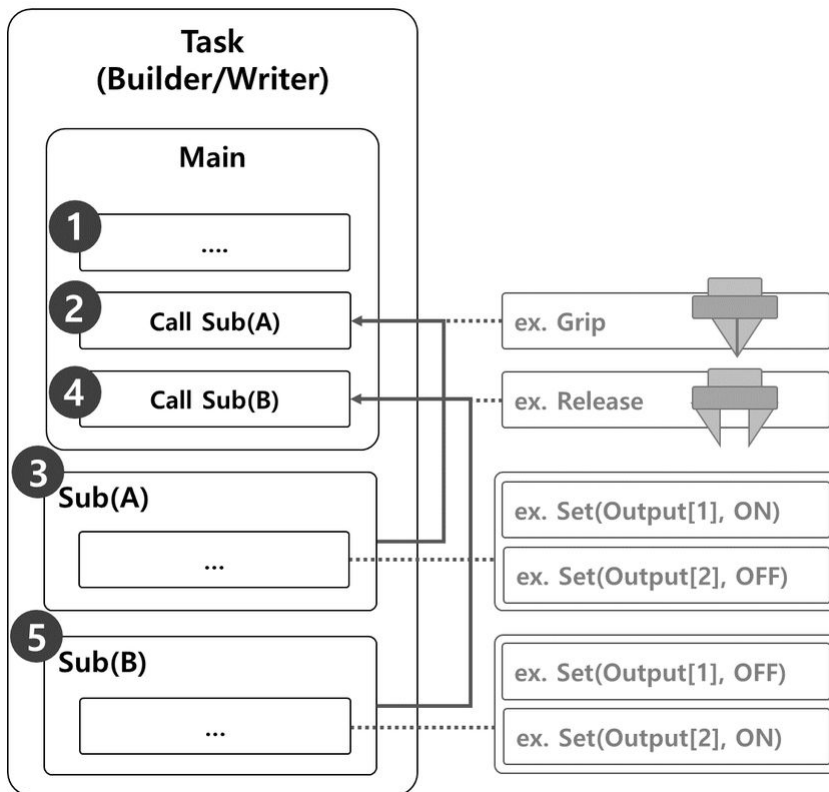

The sample where a Sub command is used to execute grip and release motions of a robot gripper consists of the following.

1. Lines of the Main paragraph execute the task program in sequential order starting from the first line.
2. Move to Sub(A) called by Call Sub.
 - Sample
 - Program: Call the Grip subroutine.
 - Robot: No motion.
3. Sub(A) is executed. All Sub paragraph lines are executed in sequential order, returns to the Main paragraph, and executes the next line.
 - Sample
 - Program: Execute the Grip subroutine lines in sequential order. Use the Set command to set Output [1] as ON and Output [2] as OFF.
 - Robot: The robot gripper executes Grip motion.
4. Move to Sub(B) called by Call Sub.
 - Sample
 - Program: Call the Release subroutine.
 - Robot: No motion.
5. Sub(B) is executed. All Sub paragraph lines are executed in sequential order, returns to the Main paragraph, and executes the next line.
 - Sample

- Program: Execute the Grip subroutine lines in sequential order. Use the Set command to set Output [1] as OFF and Output [2] as ON.
- Robot: The robot gripper executes Release motion.

Add Sub command

1. Add the Sub command from the Task Builder or Task Writer.
2. Enter the subroutine name.
3. Proceed with Confirm.

Sub Confirm

Specify the name of the subroutine.
Subroutine names should be lowercase, with words separated by underscores as necessary to improve readability.

Subroutine name

sub1 Input Subroutine name

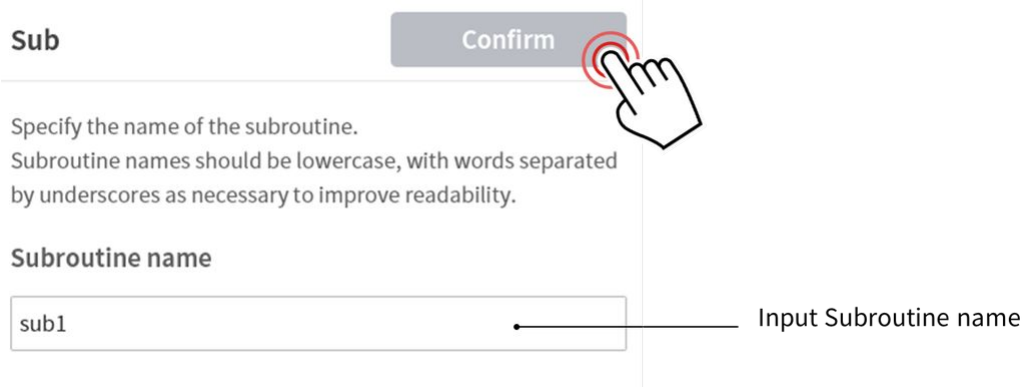

Add CallSub command

1. Add the CallSub command from the Task Builder or Task Writer.
2. Select the subroutine name registered with Sub command.
3. Proceed with Confirm.

Call Sub Confirm

Specify the name of the subroutine to call.

Subroutine name

sub1 Select Subroutine name

To go to selected Subroutine, press the button below.

Go To Selected Subroutine Go to Subroutine line

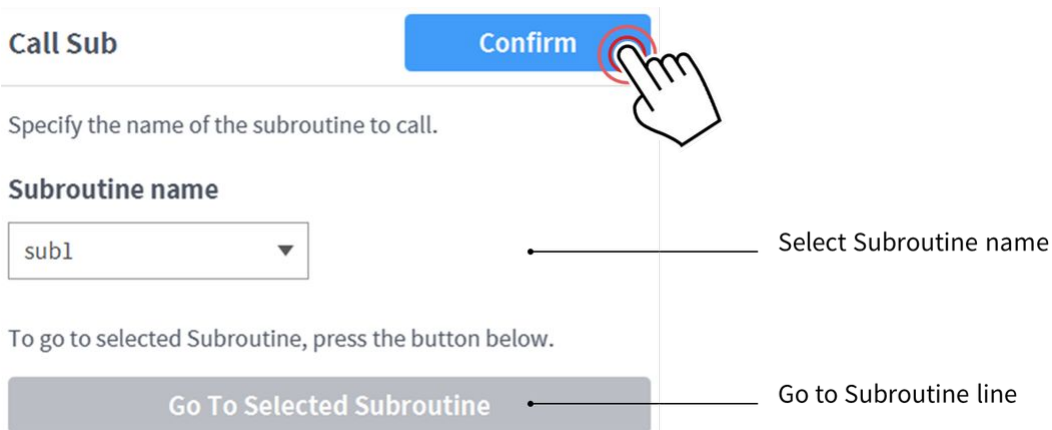

Note

If the number of lines increases in the task program, it may become difficult to find subroutines. In such case, touch the Go to selected Subroutine in the Property of CallSub command to move the focus to the corresponding Sub command line.

2.5.4 Try Compliance command samples

OPTIONAL NORMAL 20 MIN

This sample is created in the Task Writer. This sample can be tried almost the same way in the Task Builder.

Caution

Before trying the sample, make sure to read and follow [Precautions for Use\(p. 11\)](#). For more information, refer to [PART 1. Safety Manual\(p. 9\)](#).

Note

- If there is an external torque above the threshold when enabling or disabling compliance control, the robot stops the program due to the JTS (Joint Torque Sensor) error.

Threshold of JTS error (Nm)

Model	J1	J2	J3	J4	J5	J6
M1013	25	25	25	15	15	15
M0617	30	30	30	15	15	15
M0609	18	18	15	15	15	15
M1509	18	18	15	15	15	15
H2515	40	50	40	15	15	15
H2017	40	50	40	15	15	15

- Stiffness change can be executed regardless of the external torque size.
- During compliance control, joint motions, such as MoveJ command, cannot be executed.

1. Select the Task Writer from the bottom menu.
2. Enter the task name and press the OK button.
3. Select the MainSub command from the third line of the task list. A new command is added to the next line of the selected line.
4. Add Compliance Command. This command is planned to be used for enabling Compliance Control.
5. Add another compliance control. This command is planned to be used for disabling Compliance Control.

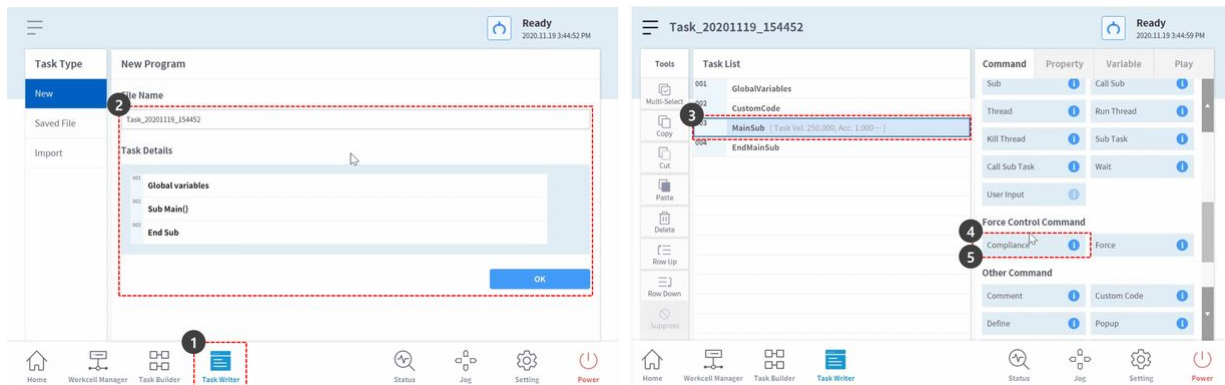

6. Select the Compliance Command on the fourth line. A new command is added to the next line of the selected line.
7. Add Wait command.
8. Select the Property tab.
9. Set the wait time as the following:
 - Wait Time: 100 sec
10. Press the Confirm button.

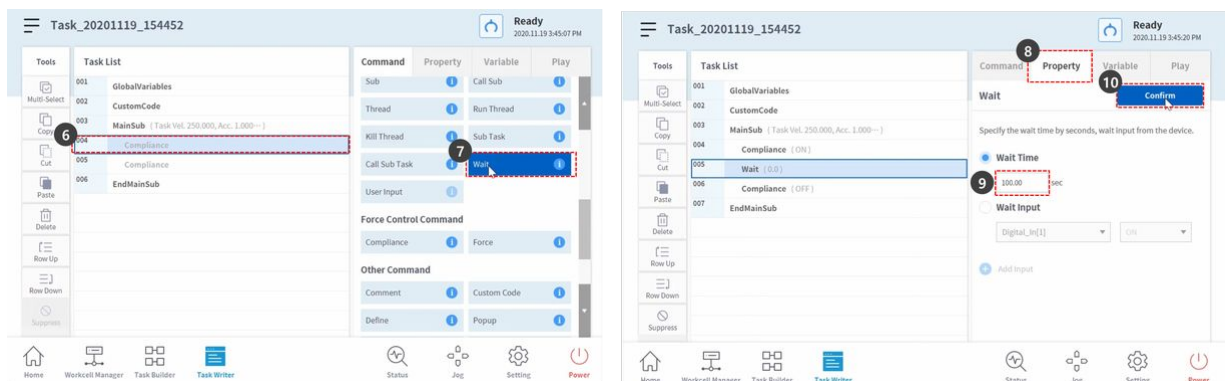

11. Select the Compliance Command on the sixth line.
12. Set the mode in the property as the following: Mode Off disables compliance control.
 - Mode: Off
13. Press the Confirm button.
14. Select the Compliance Command on the fourth line.
15. Set the Mode in the Property as the following: Mode On enables Compliance Control.
 - Mode: On
16. Set the Stiffness as the following: Lower the stiffness of X and Y direction for softer reactions in X and Y directions.
 - X: 200 N/m
 - Y: 200 N/m
 - Z: 3000 N/m (default)
 - Rx, Ry, Rz: 200 Nm/rad (default)
17. Press the Confirm button.

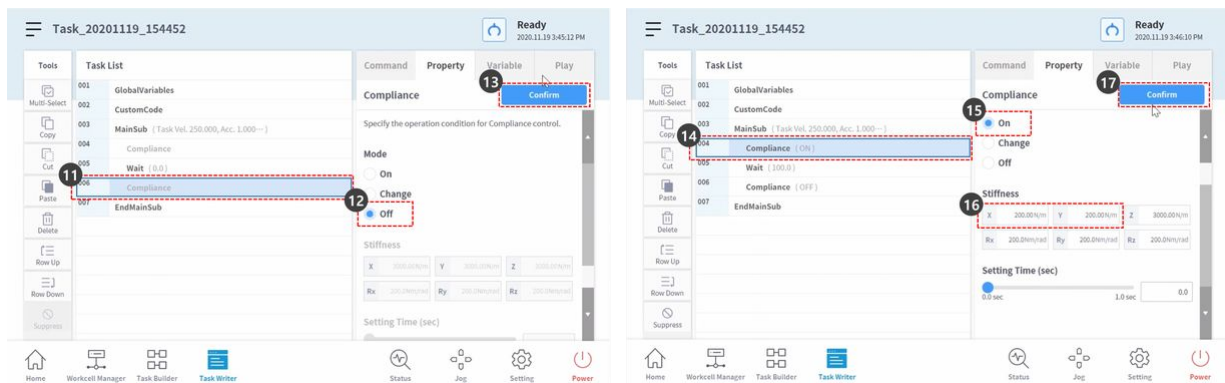

18. Select the Play tab.

19. Enable the Real Mode toggle button.

- Once the toggle button becomes enabled, the button lights up green.

20. This sample will deliberately activate the Safety Stop to explain the reason to lower Collision Sensitivity during Compliance control. The Collision Sensitivity of this sample is 95%. In cases with such high collision sensitivity, the robot reacts to collisions very sensitively.

- Upon collision, the robot is stopped by the Safety Stop.

21. Press the Play button.

22. Hold the robot end and slowly push it in the robot body direction. The robot stops due to collision error.

During Safety Stop due to collision, the robot LED lights up yellow.

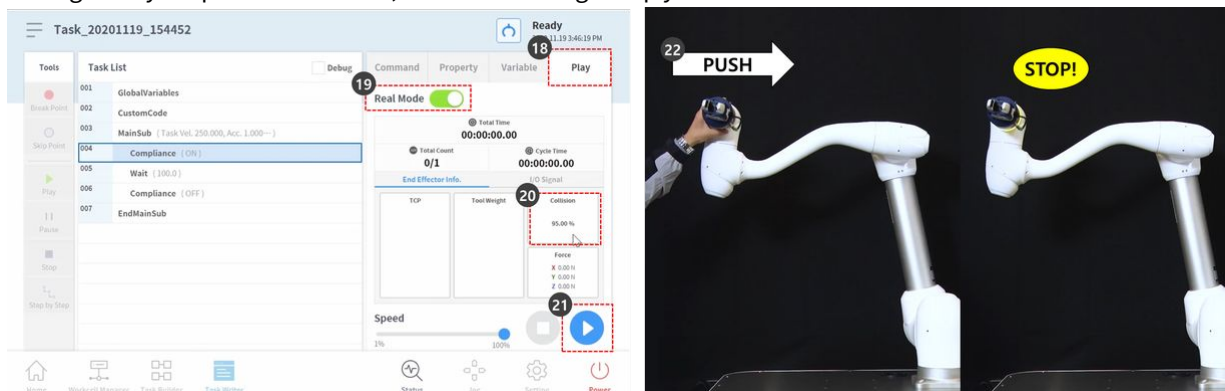

23. Press the Program Stop button in the yellow safety stop warning window on the screen. The task program in progress is stopped.

24. Select the Workcell Manager from the bottom menu.

25. Select Robot > Robot Limits.

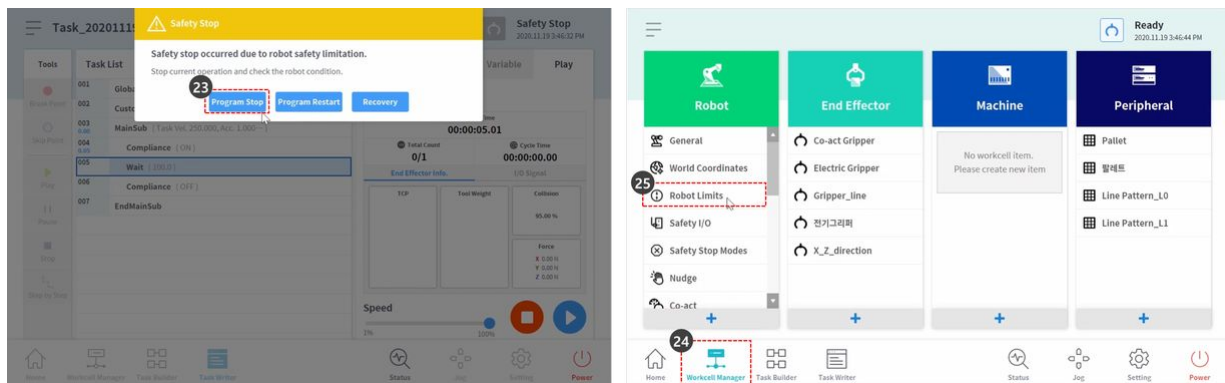

26. Select the TCP/Robot tab.
27. Press the Edit button.
28. Set the Collision Sensitivity as the following:
 - Normal mode: 50 %
29. Press the Draft button.
30. Check the Confirm draft checkbox and press the Confirm button.

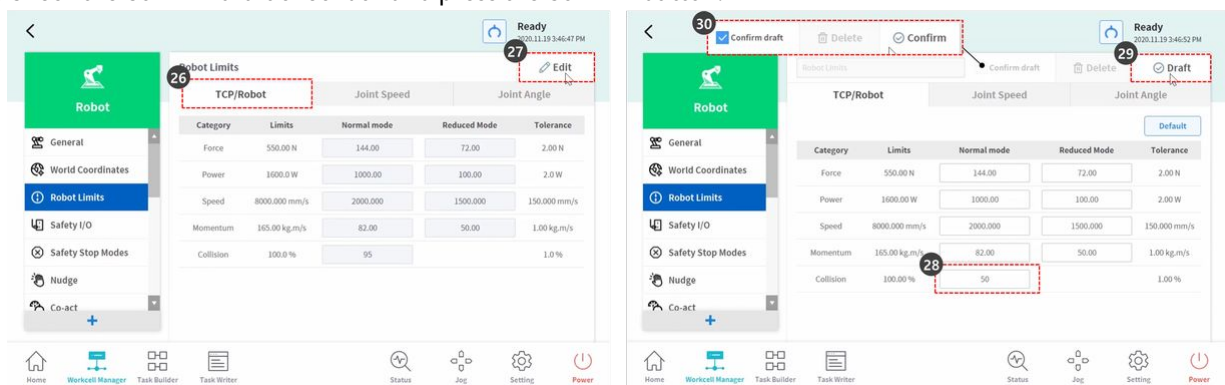

31. Select the Task Writer from the bottom menu.
32. Select the Saved file on the screen left.
33. Check whether the first task file name is the task name in Step 2 before selecting. The last saved task is located on the top of the Task Writer file list.
34. Press the Open button.
35. Select the Play tab.
36. Enable the Real Mode toggle button.
37. Press the Play button.

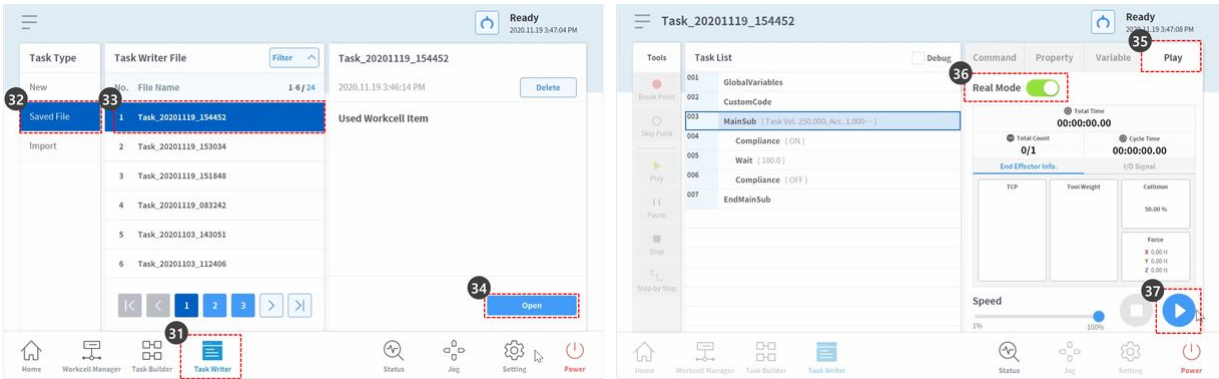

38. Hold the robot end and slowly push it in the robot body direction. The robot moves due to the pushing force and returns to its original position.

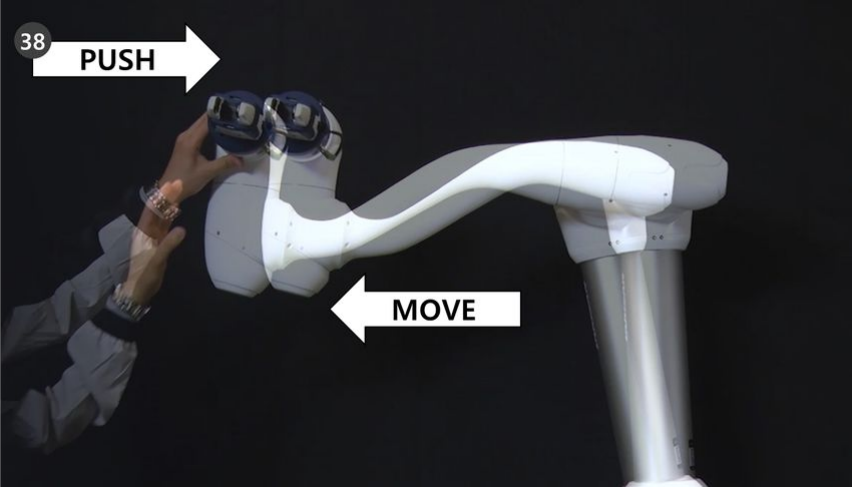

2.5.5 Understand robot motion

MANDATORY **EASY** 5 MIN

Doosan Robotics robots offer nine motions. Robot movement is controlled by standard motions, MoveJ and MoveL, and 7 motions derived from these two motions.

Types of Robot Motion

Motion	Feature
--------	---------

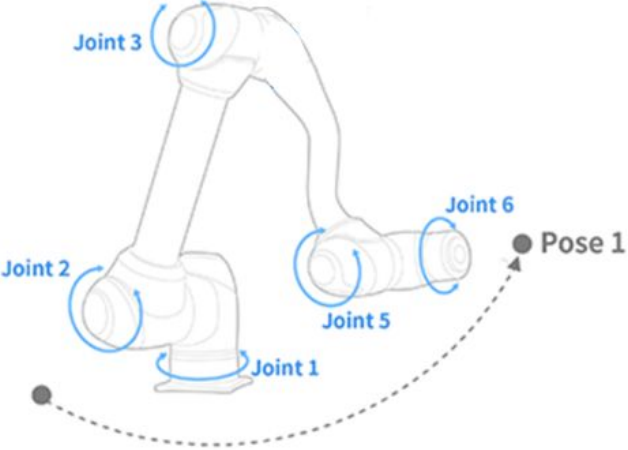
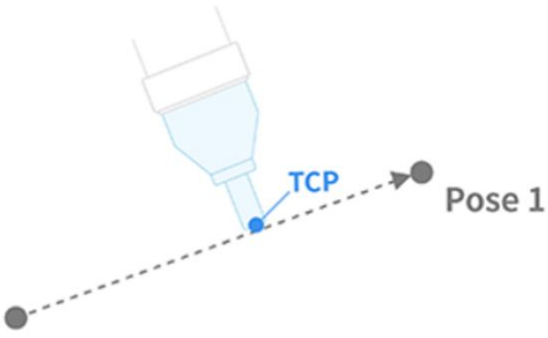
1	MoveJ	<p>Each joint of the robot moves from the current angle to the target angle and stops simultaneously</p> <ul style="list-style-type: none"> • Enter target joint angle: Joint1, Joint2, Joint3, Joint4, Joint5, Joint6 
2	MoveL	<p>Robot moves to the target point while maintaining the robot TCP straight</p> <ul style="list-style-type: none"> • Enter target position and rotation values: X, Y, Z, A, B, C 
3	MoveSJ	<p>Robot moves throughout all angles set by the robot</p> <ul style="list-style-type: none"> • Joint spline motion movement • As it is a robot joint movement, the path cannot be estimated
4	MoveSX	<p>Robot TCP moves throughout all points</p> <ul style="list-style-type: none"> • Task spline motion movement

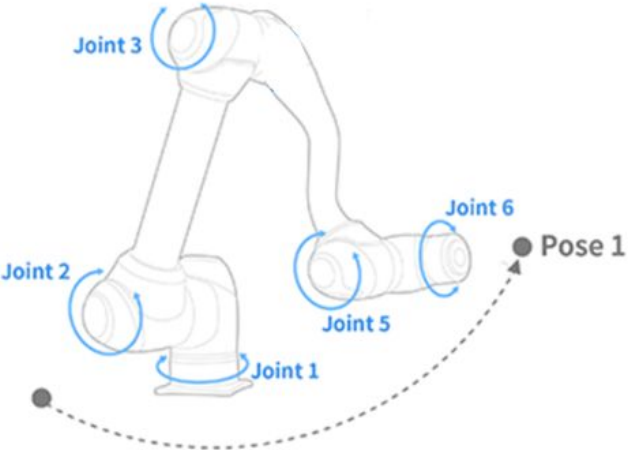
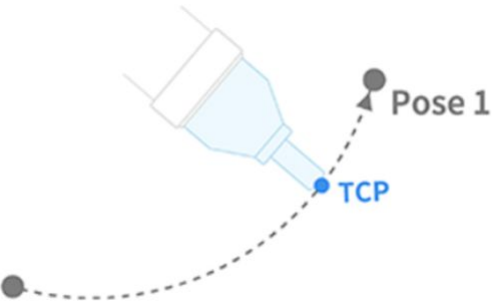
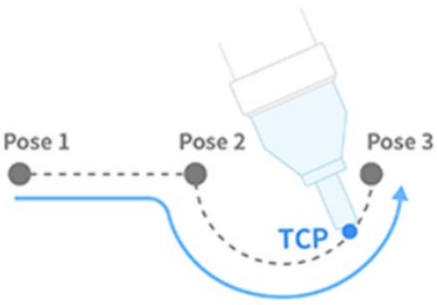
5	MoveJX	<p>The robot pose is designated as the robot TCP moves to the target point</p> <ul style="list-style-type: none"> • MoveJ motion movement to the target point (X, Y, Z, A, B, C) • As it is a robot joint movement, the path cannot be estimated 
6	MoveC	<p>Robot TCP moves to target point while maintaining an arc</p> 
7	MoveB	<p>Robot moves to the final target point through a section consisting of continuous straight lines and arcs</p> 

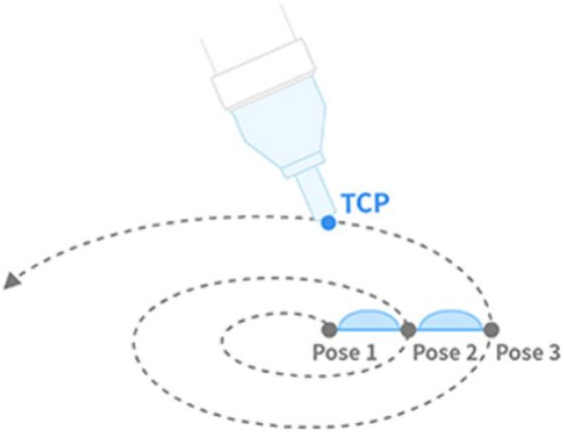
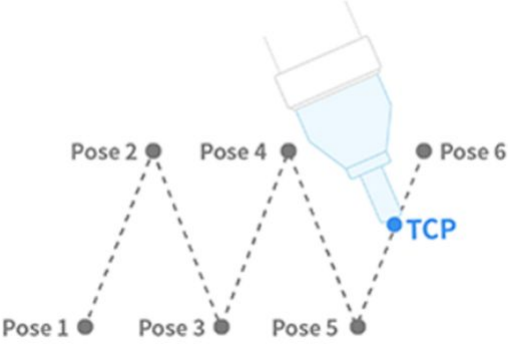
8	MoveSpiral	<p>Robot moves from the spiral center to the maximum radius</p>  <p>The diagram shows a robot arm with a blue TCP (Tool Center Point) moving along a dashed spiral path. The path starts at a center point and moves outwards in a clockwise direction. Three specific poses are marked: Pose 1, Pose 2, and Pose 3, which are located on the inner part of the spiral. The TCP is shown at the end of the spiral path.</p>
9	MovePeriodic	<p>Robot moves in a path with a constant amplitude and cycle</p>  <p>The diagram shows a robot arm with a blue TCP moving in a periodic path. The path consists of six poses connected by dashed lines, forming a zigzag pattern. The poses are labeled Pose 1 through Pose 6. Pose 1, 3, and 5 are on the bottom line, while Pose 2, 4, and 6 are on the top line. The TCP is shown at the end of the path, positioned near Pose 6.</p>

MoveJ&MoveL

Before using robot motion, it is critical to understand the standard motions MoveJ and MoveL.

- J in MoveJ refers to joints. In this motion, each joint moves to the target angle and stops simultaneously.
- L in MoveL refers to linear. In this motion, the TCP on the robot end moves to the target pose (position and angle) with linear motion.

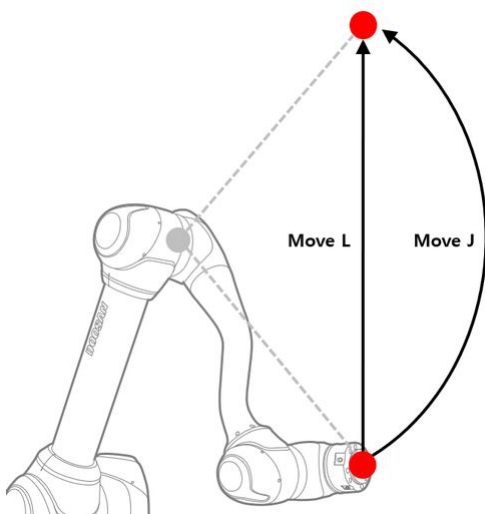

	Type	MoveJ	MoveL
1	Move Method	<ul style="list-style-type: none"> All joints of the robot move from the current angle to the target angle and stop simultaneously 	<ul style="list-style-type: none"> TCP on the robot end moves to the selected coordinates with linear motion
2	Advantage	<ul style="list-style-type: none"> Fast movement speed Not influenced by a robot singularity 	<ul style="list-style-type: none"> As TCP path maintains a straight line, the movement path of the robot can be estimated As target point is indicated using position and rotation (X, Y, Z, A, B, C), the approximate robot end point can be estimated
3	Disadvantage	<ul style="list-style-type: none"> As all axes rotate to the target angle simultaneously, movement path cannot be estimated As target angle is indicated with the angle of each axis, it is difficult to estimate the robot end point and robot pose 	<ul style="list-style-type: none"> Motion speed is relatively slower than MoveJ Influenced by a robot singularity
4	Utilization	<ul style="list-style-type: none"> As it is not influenced by a robot singularity, it is used to avoid singularities It is ideal in moving long distances 	<ul style="list-style-type: none"> It is ideal in avoiding objects and fine movement

2.5.6 Try the sample MoveJ/MoveL commands

MANDATORY **NORMAL** 20 MIN

In this sample, add MoveJ and MoveL commands in the Task Builder, execute them and compare the difference between the two motions.

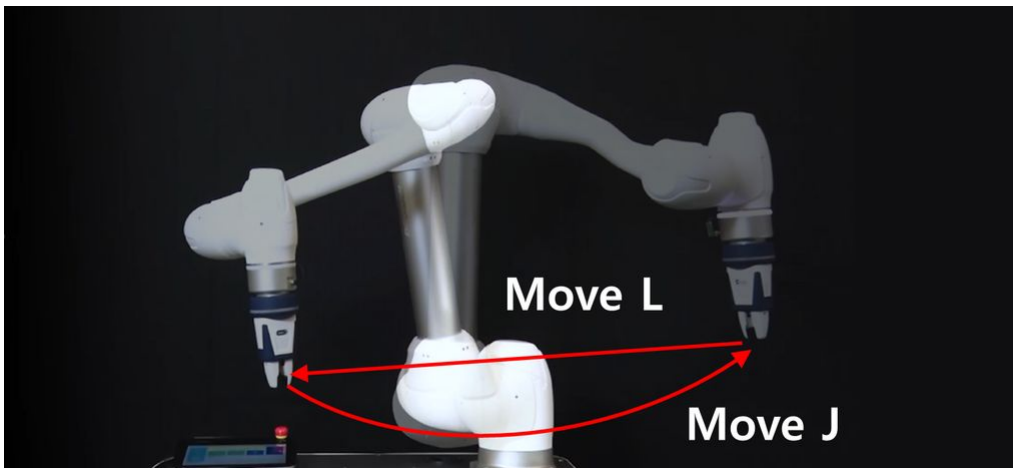

⚠ Caution

Before trying the sample, make sure to read and follow [Precautions for Use](#)(p. 11). For more information, refer to [PART 1. Safety Manual](#)(p. 9).

1. Select the Task Builder from the bar at the bottom of the screen.
 - The programming method in the Task Writer is almost identical to that of the Task Builder.
2. Press the Next button.
 - To create a program with registered Workcell Items, such as grippers, a Workcell Item must be added.
 - In this sample, press the Next button without selecting any Workcell Items and skills.
3. Enter a task name.
4. Press the Confirm button.

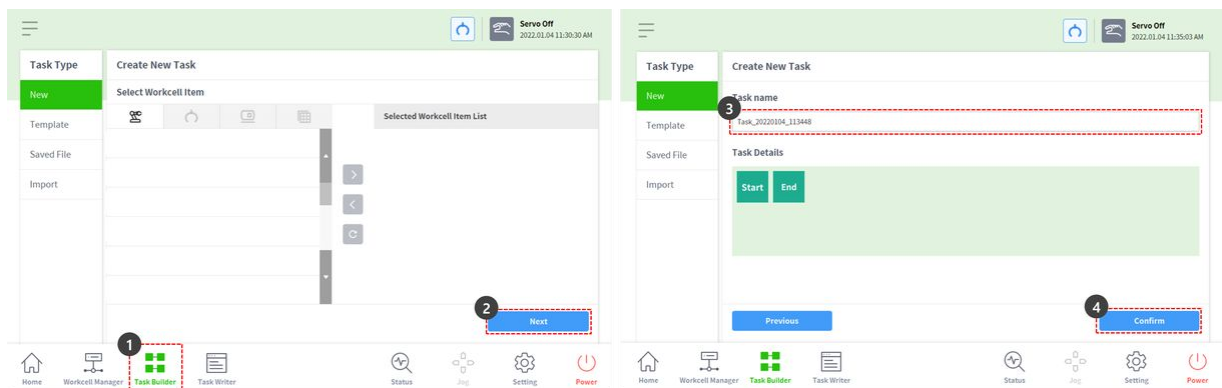

5. With MainSub on the second line selected, press MoveJ to add MoveJ command to the task list.
 - Command is added to the following line of the selected one.
6. Press MoveL to add MoveL command to the task list.
7. Select MoveJ on the third line of the task list.
8. Select the Property tab at the top right. Property values of the command can be set in the Property tab.

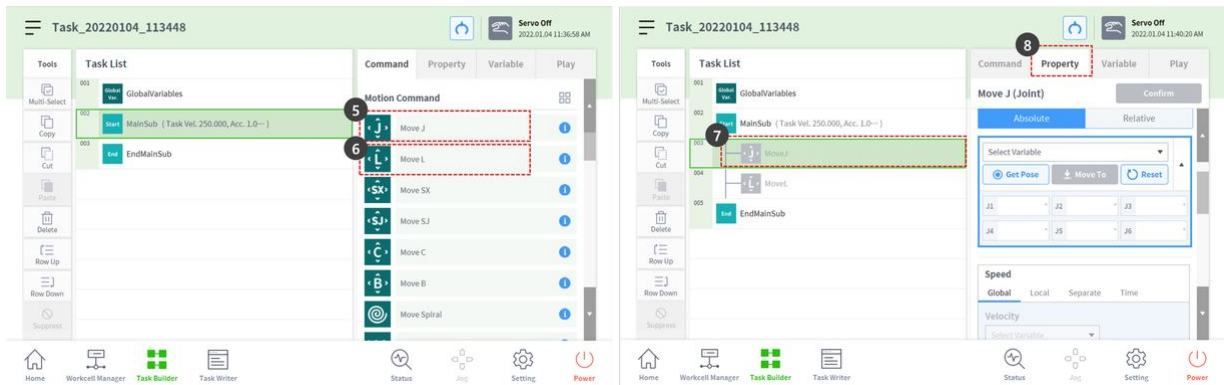

9. Use one hand to press and hold the hand guiding button, which has a hand shape, located on the cockpit at the top of the robot end. Step 9 to 11 saves the pose of MoveJ.

- In case of robots which cannot use a cockpit, check the “Note” below.

10. Use the other hand to push the robot to a safe location.

11. Release the hand guiding button and press the save pose button.

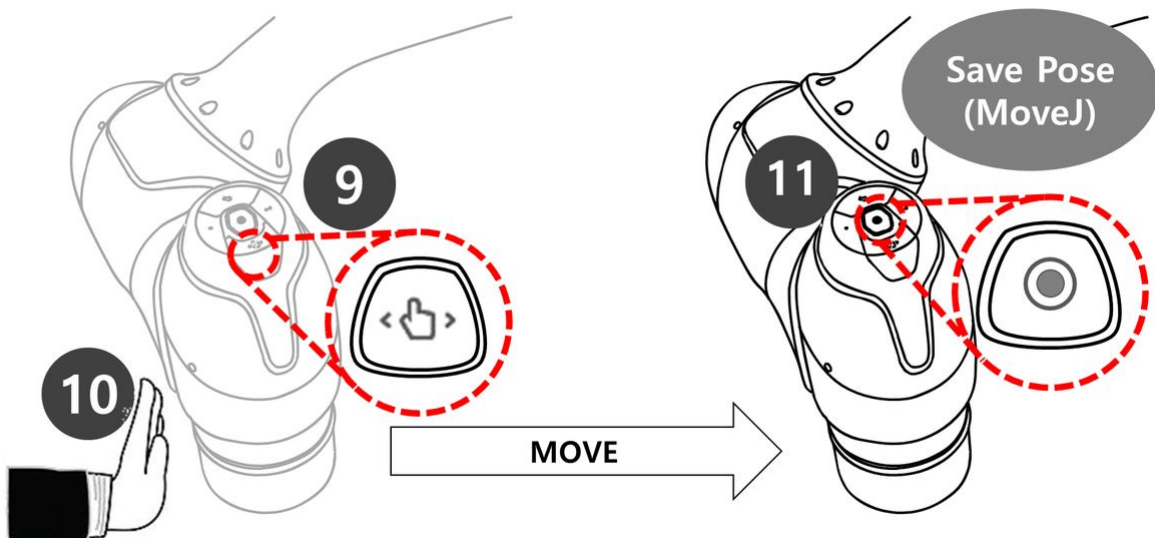

12. Use one hand to press and hold the hand guiding button, which has a hand shape, located on the cockpit at the top of the robot end. Step 12 to 14 saves the pose of MoveL.

- There is no need to select MoveL of the task list. If the save pose button is pressed, the task list automatically moves to the task line.

13. Use the other hand to push the robot to a safe location.

14. Release the hand guiding button and press the save pose button.

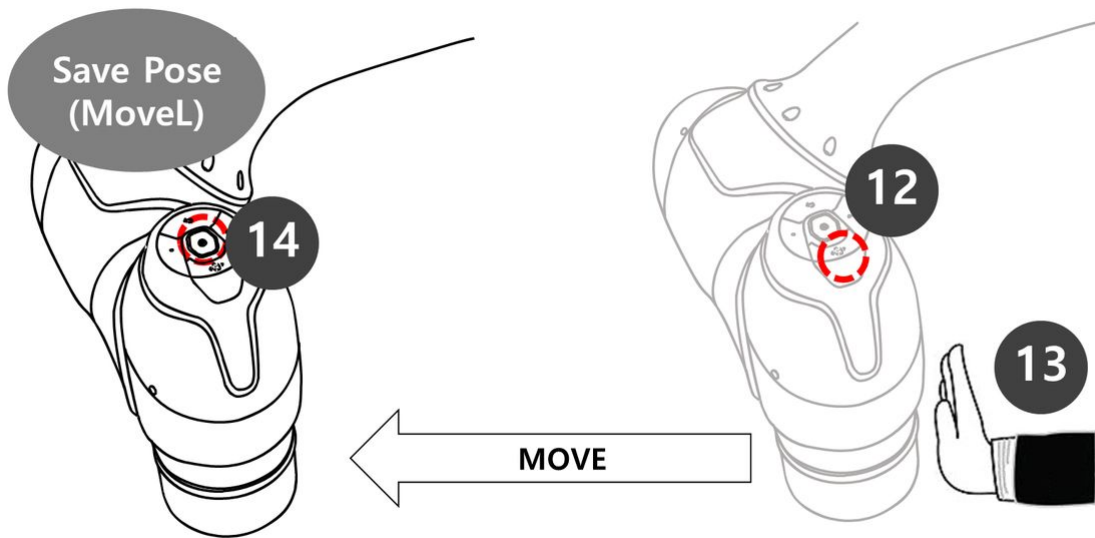

15. Press the Play tab to perform the task.
16. As the task is not saved, a popup window asking to save the task is displayed. Press Save.
17. Set the real mode toggle button to disabled status (grey).
 - a. If the real mode is disabled, the robot does not move and only the virtual robot in the screen simulator moves.
 - b. Before performing the task, it is recommended to test the task in this simulation mode.
18. Press the Play button at the bottom right.

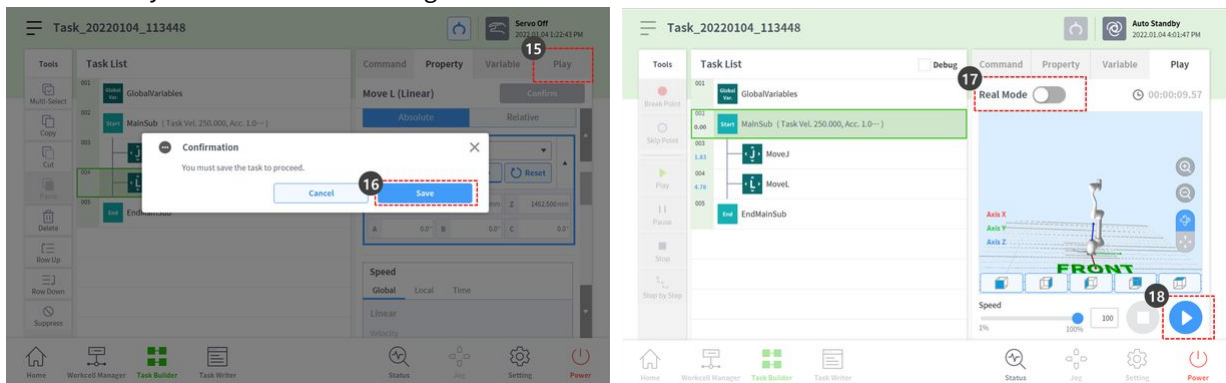

19. An error message stating the robot is not ready is displayed. Press the X button to close the popup.

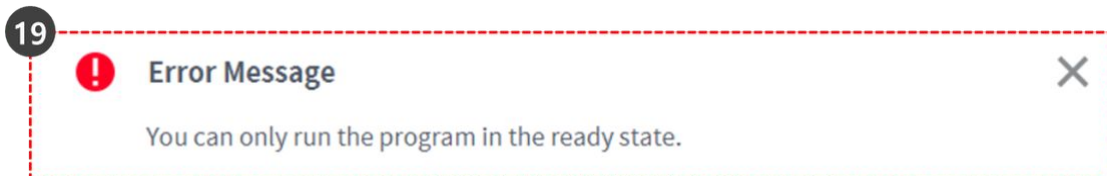

- The robot can only move in Servo On status.
- The Servo On and Servo Off of the robot can be turned on and off through **Status > Servo**.

20. To set the robot in ready status, the robot must be set to servo on. Select the Status on the bar at the bottom.
21. Press the Servo On button.
22. Press the X at the top left to close the Status window.
23. Press the Play button at the bottom right again. The robot will move successfully in the simulator.

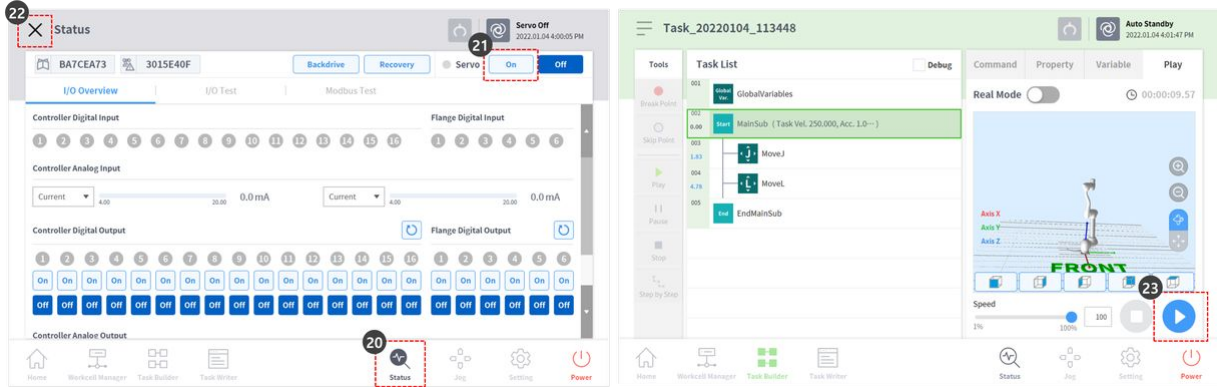

24. Set the real mode toggle button to enable status (green) to operate the actual robot.
25. Press the Play button at the bottom right. The actual robot will successfully move.

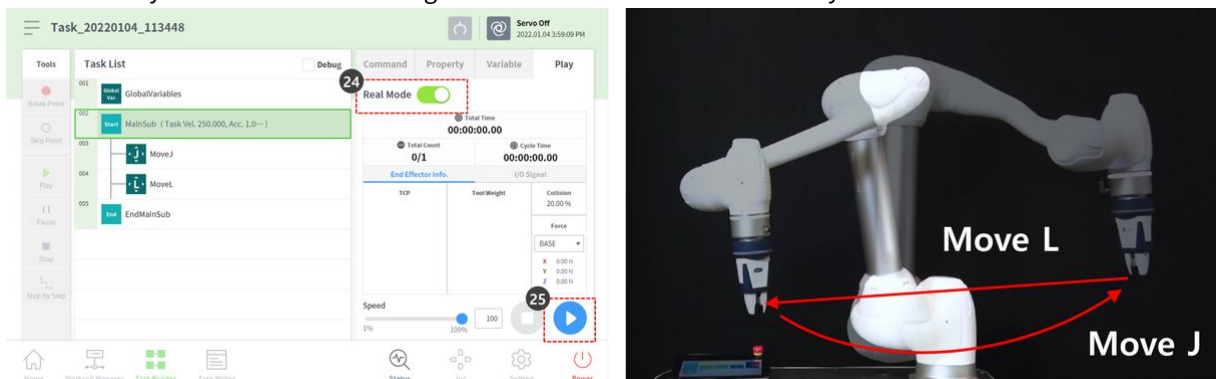

Note

The save pose button of the cockpit performs the following function in the same order on the teach pendant screen.

1. Press **Property > Get Pose** button to load the current pose information.
2. Press the **Confirm** button to save changes in the command property.
3. Select the next command.

With this, it is possible to quickly program tasks by adding multiple motion commands to the task list at once, moving the robot while pressing the hand guiding button on the cockpit, and pressing the get pose button.

2.5.7 Understand robot motion properties

MANDATORY **NORMAL** 15 MIN

It is the property screen of the standard motions, MoveJ and MoveL commands. Other motions also have similar properties.

- If motion is created with minimum settings, only the pose information (5 in the figure below) needs to be entered.

Name	Description
1	Enter annotation
2	Coordinates
3	Absolute / Relative mode
4	Select Variable
5	Get Pose / Move To / Reset buttons
6	Speed (Global / Local / Time)
7	Operating mode (Sync / Async)
8	Blending mode (Duplicate / Override)

1	Annotation	Description or annotation of the command which can be found in the task window
2	Coordinates	<ul style="list-style-type: none"> • MoveJ: None • MoveL: Calculates the entered pose information based on the coordinates (BASE/WORLD/TOOL/USER)
3	Select move type	<ol style="list-style-type: none"> 1. Absolute movement <ul style="list-style-type: none"> • MoveJ: Each joint moves to the target angle • MoveL: Performs absolute movement by the target value based on the origin of the selected coordinates 2. Relative movement <ul style="list-style-type: none"> • MoveJ: Each joint performs relative movement by the target angle from the current angle • MoveL: Performs relative movement by set value based on the current point (relative movement based on the selected coordinates)
4	Select variable	Pose information registered as variables can be selected
5	Pose information	<p>Pose information is entered</p> <ul style="list-style-type: none"> • MoveJ: Angle of each axis ([J1, J2, J3, J4, J5, J6]) • MoveL: Position and rotation from coordinates ([X, Y, Z, A, B, C])
6	Speed setting	<ol style="list-style-type: none"> 1. Global: Uses the speed designated as global in the property of MainSub 2. Local: Each speed is designated 3. Separate: <ul style="list-style-type: none"> • MoveJ: Each joint speed is designated separately • MoveL: None 4. Time: Movement speed of the motion is set as time
7	Operation mode	<ol style="list-style-type: none"> 1. Sync: The motion command in progress is done and the next command is executed 2. Async: The next command is done simultaneously when the motion command begins 3. Radius: The async function is activated in the radius section before the motion command reaches its target point
8	Blending mode	The option used to determine whether to ignore or overwrite the preceding motion according to the blending mode of the following motion when the radius is set as an option of the preceding motion

Operating mode

Sync

You can move to the next command with Sync when the command in progress is completed. It is set as default, and used in general situations.

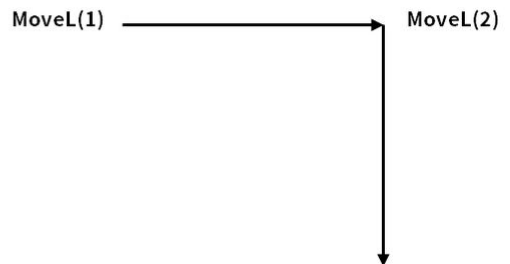
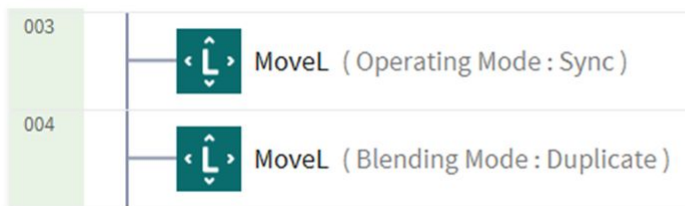

Async

Async starts the next command simultaneously when the motion command begins. It is used to smoothly connect different motions, and it is also used when signal output is turned on/off simultaneously when the motion begins.

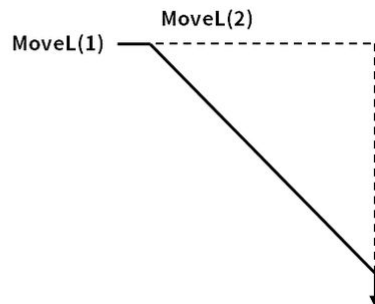
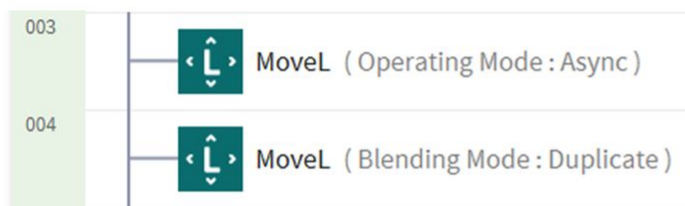

Radius

Radius option activates the async function in the radius section before the motion command reaches its target point. With this option, it is possible to smoothly connect to the next motion command without stopping the current motion command. The radius is set to 0 mm as default.

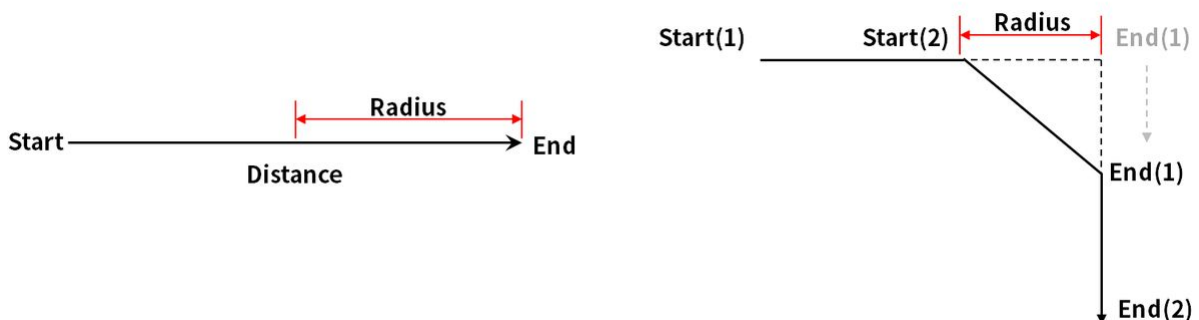

⚠ Caution

Radius option has following characteristics and limits:

- Radius function can only be used in sync mode.
- Conditions and calculations can be performed in the async section within the radius.
- Radius cannot exceed 1/2 of the total distance between the current and target location before the motion is executed.
 - ex. If the movement distance is 100 mm, the maximum radius available is 50 mm.
- Motion commands which cannot apply Blending between motions are as follows: Blending is already applied in these commands, so applying radius to these commands and executing them causes errors. Utilizing commands, such as WaitMotion and StopMotion, can help avoid errors.
 - MoveSX, MoveSJ, MovePeriodic, MoveSpiral, MoveB

Blending mode

It is the option used to determine whether to ignore or overwrite the preceding motion according to the blending mode of the following motion when the radius is set as an option of the preceding motion.

Duplicate

Duplicate is a mode that maintains the preceding motion to allow the following motion to overlap with the preceding motion.

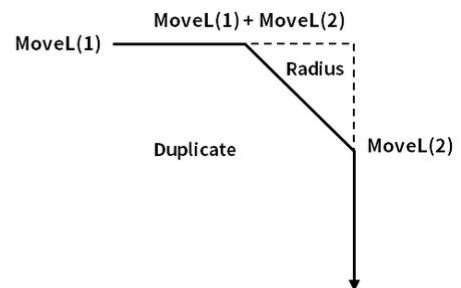
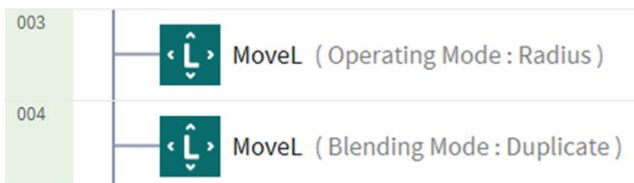
**Override**

Override ignores and overwrites the preceding motion to execute the following motion.

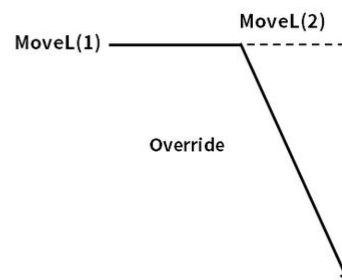
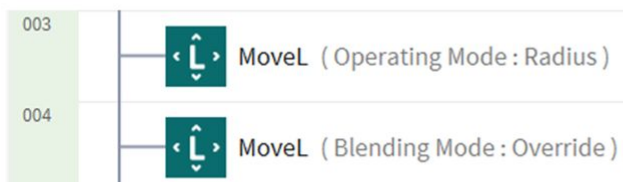

2.5.8 Skill - Try Pick & Place samples

OPTIONAL **NORMAL** 20 MIN

This sample is created in the Task Builder. The Task Writer does not support the skill function.

⚠ Caution

Before trying the sample, make sure to read and follow [Precautions for Use\(p. 11\)](#). For more information, refer to [PART 1. Safety Manual\(p. 9\)](#).

1. Select the Task Builder from the bottom menu.
2. Select the Select Workcell Item > Gripper icon.
3. Select the gripper registered as a Workcell Item. This sample cannot be tried if there is no gripper registered as a Workcell Item.
4. Press the > button to register the Workcell Item as the selected Workcell Item.
5. Press the Next button.
6. Enter the task name.
7. Press Confirm.

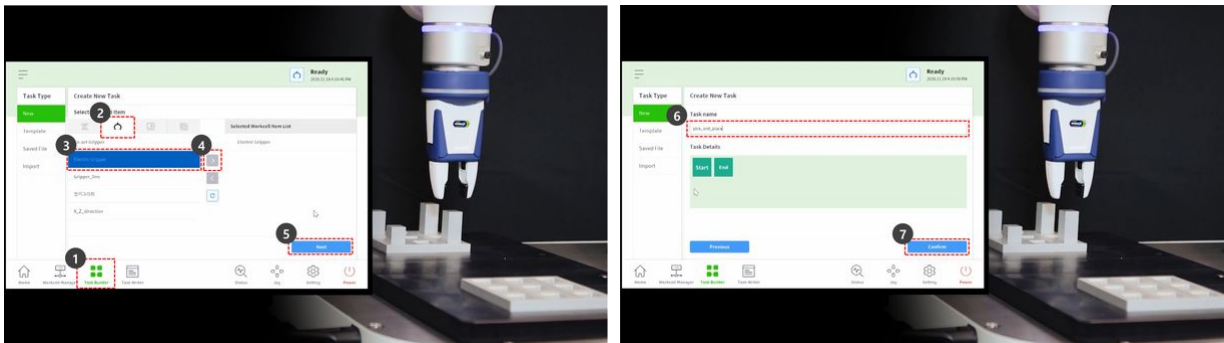

8. Select the MainSub command from the second line of the task list. A new command is added to the next line of the selected line.
9. Add the Pick skill command.
10. Add the Place skill command.
11. Select the Pick command from the third line of the task list.
12. Select the Property tab.
13. Press the Workcell Item Action to expand the menu. If the gripper Workcell Item is selected, gripper action can be tested during Workcell Item action.

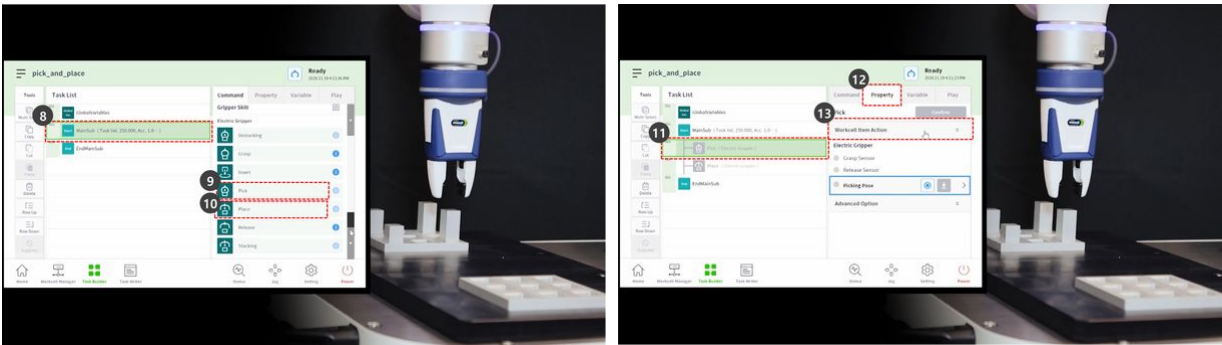

- 14. To test the gripper, press the Grasp button and perform grasp motion.
- 15. To test the gripper, press the Release button and perform release motion.

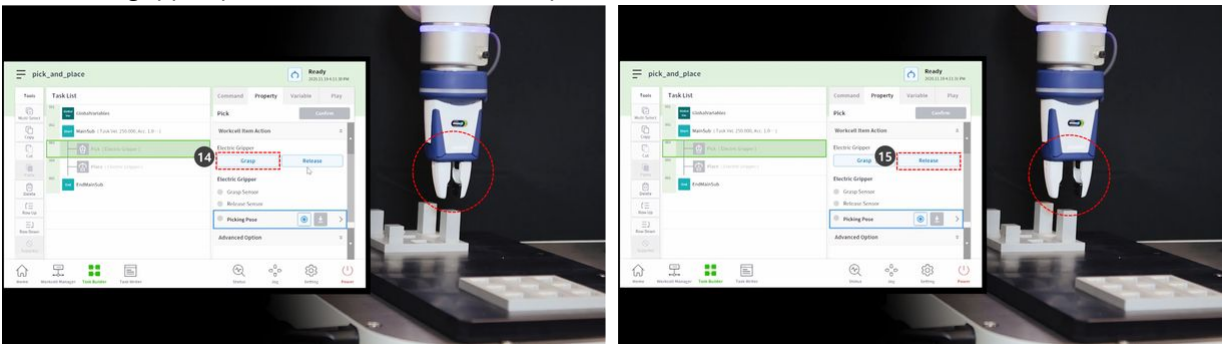

- 16. In case of light workpieces, place the workpiece in the gripper and press the Grasp button to make the robot hold the workpiece. Performing teaching while the gripper is holding a workpiece can help establish an accurate position.
 - However, having the robot hold a workpiece during teaching is not mandatory but an example.
 - In the case of heavy workpieces, dangerous situations can occur as the gripper can lose the workpiece.
 - In the case of heavy workpieces, the Tool Weight of the Tool Settings must include the tool weight and the workpiece weight.
- 17. Use direct teaching to move the robot to the point where Pick will be performed.
 - Press and hold the hand guiding button in the cockpit to move the robot.
- 18. Press the Get Pose button of the Picking Pose.
- 19. Press the Confirm button.

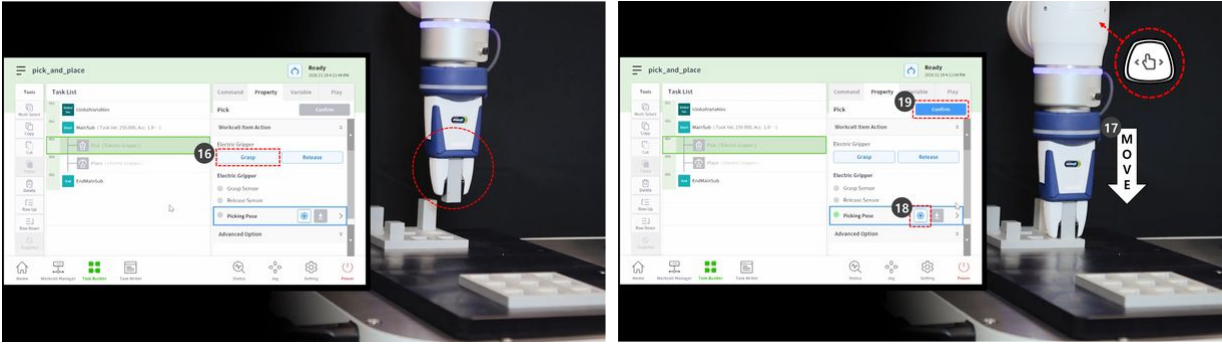

20. Use direct teaching to move the robot to the point where Place will be performed.
21. Press the Get Pose button of the Placing Pose.
22. To release the workpiece from the gripper, press the Release button.
23. Press the Confirm button.

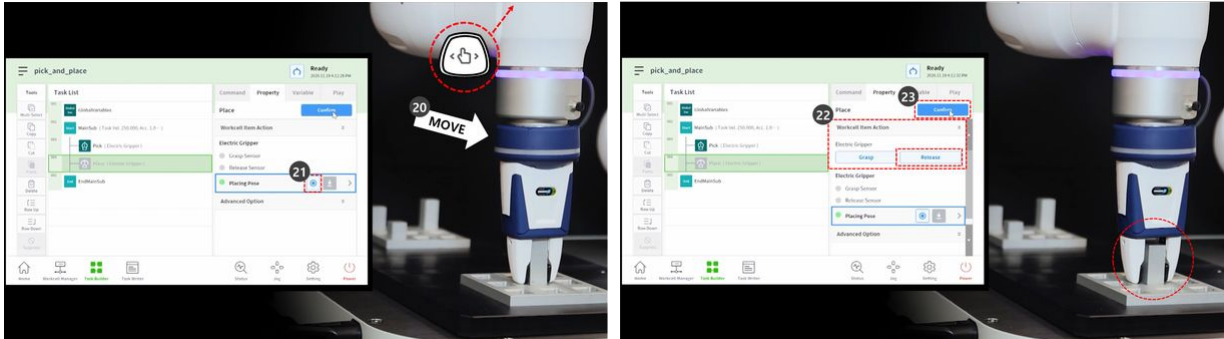

24. To set detailed settings of Pick and Place skill commands, select the Pick command in the third line of the task list.
25. Press the Advanced Option to expand the menu and set as following: Use default values for items not described below.
 - a. Entry Direction: Z-axis
 - It sets the direction for entering the Pick position.
 - b. Approach Distance: 100 mm
 - It sets the distance right before the robot approaches the Pick position. It secures sufficient approach distance.
 - c. Retract Distance: 100 mm
 - It sets the distance after the robot retracts in the set direction from the Pick position. It secures sufficient retract distance.
 - d. Approach Speed: 100 mm/s
 - It sets the approach speed lower than the default value when the robot approaches an object.
 - e. Compliance Control: Enabled (green)
 - f. Sensing Contact: Enabled (green)
 - It enables Compliance Control and contact detection functions.
 - Contact Force: 10N
 - Contact Tolerance: 10 mm
 - Force: 15N
 - Scratch Offset: 2mm
 - g. Release Gripper Before Picking: Enabled (green)
 - It sets the gripper in the Release state before approaching the pick location.
 - h. Tool Weight: None
 - If the workpiece is not light, the workpiece weight and tool weight must be summed, be added as a Tool Weight Workcell Item, and be selected.
26. Press the Confirm button.
27. Select the Place command from the fourth line of the task list.

28. Press the Advanced Option to expand the menu and set as following: Use default values for items not described below.

- a. Entry Direction: Z-axis
- b. Approach Distance: 100 mm
- c. Retract Distance: 100 mm
- d. Approach Speed: 100 mm/s
- e. Compliance Control: Enabled (green)
- f. Sensing Contact: Enabled (green)
 - It enables Compliance Control and contact detection functions.
 - Contact Force: 10N
 - Contact Tolerance: 10 mm
 - Force: 15N
- g. Tool Weight: None

29. Press the Confirm button.

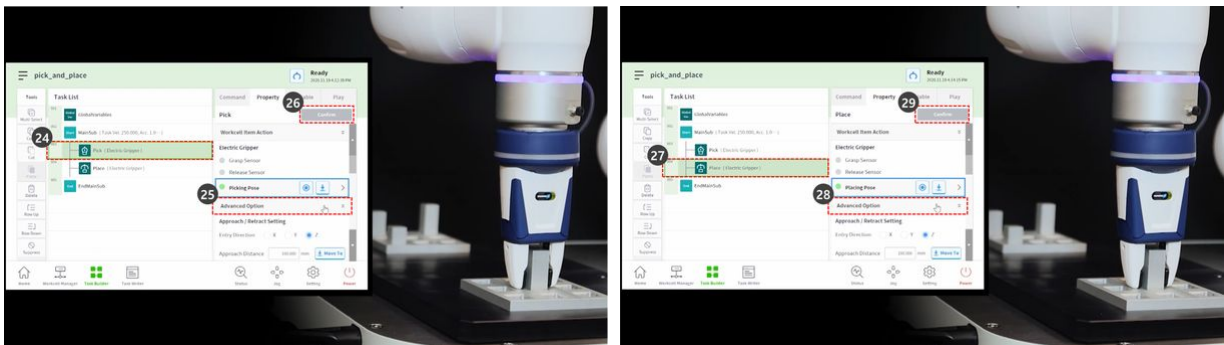

30. Use direct teaching to move the robot to the point where Pick&Place will start.

31. Move a workpiece to the Pick location.

32. Select the Play tab.

33. Enable the Real Mode toggle button.

34. Adjust the speed slide bar to 10-30%.

- This speed slide bar adjusts the set speed of all commands to the selected %.
- When a task is executed for the first time after its creation, executing it at a low speed may prevent unexpected risks.

35. Press the Play button.

36. If the task is completed without issues, adjust the speed back to the default, 100%, and test again.

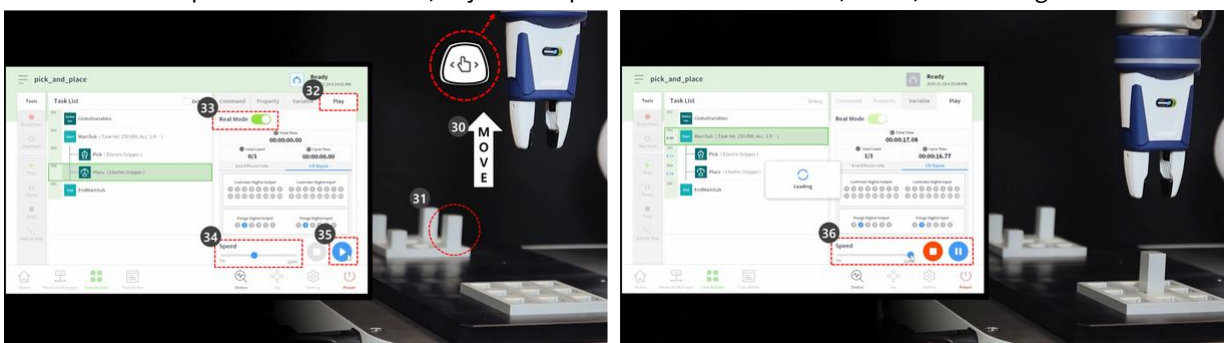

2.5.9 Utilize Step Run

The teach pendant offers the Step Run function, which allows users to execute a task program from a specified command step within Task Builder/Writer.

This function can be utilized with debugging function for effective program creation.

This description explains the Step Run function and its usage based on Task Builder, but the same procedure can be used in Task Writer.

Note

- In order to execute the task using step run function, the robot must be in Servo On state. Press the **Status > Servo On** button to set the robot to Servo On.
- Step Run feature is not available for these following commands:
 - *GlobalVariables*
 - *Custom Code above Mainsub*
 - *Break*
 - *Exit*
 - *Continue*
 - *Segments of Move SX, Move SJ, Move B*
 - *Child commands within Vision / Conveyor / Watch Smart Pendant*
 - *Thread and the child commands within the Thread*
 - *Custom Code using Script file*

The usage scenario is as follows:

1. Enter the Play tab within Task Builder/Writer.
2. Select the Step Run checkbox. (1)

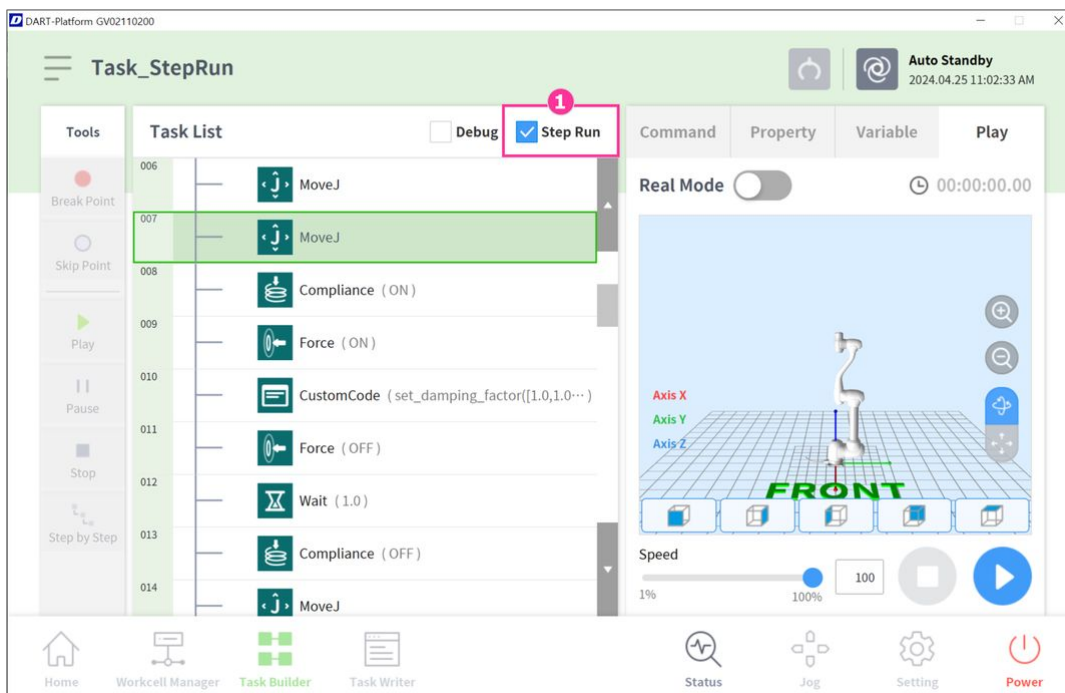

3. Select the program execution mode. (Real mode/Virtual mode)

4. Select the command to start from in the Task List (2), then press the Play button.(3)

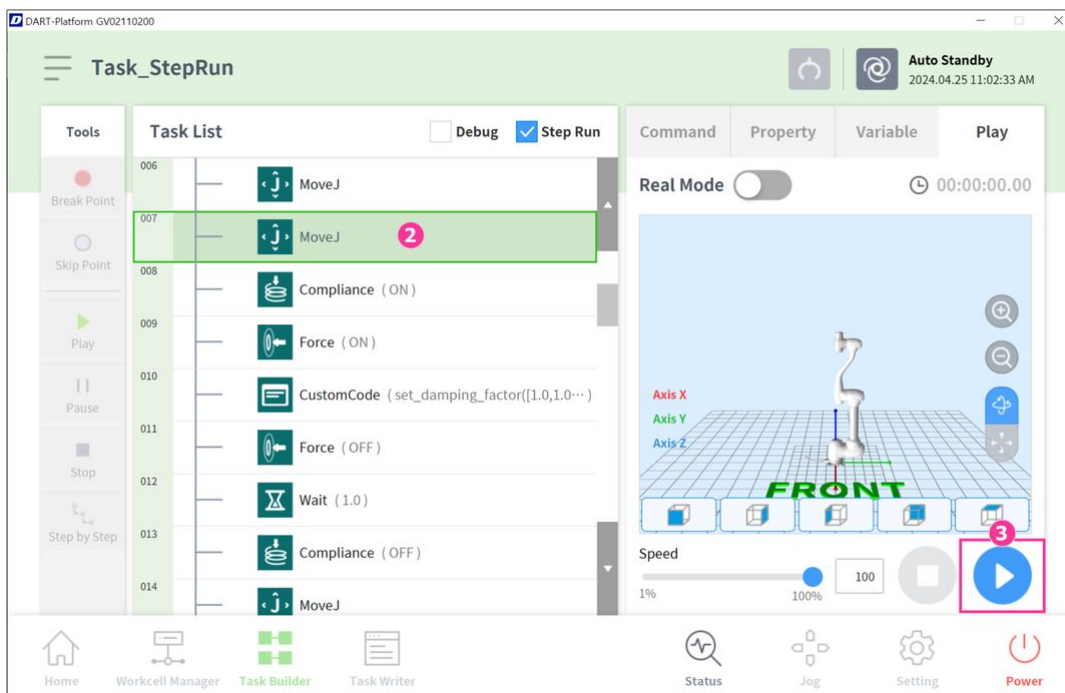

5. In the Step Run Mode popup, select the (4) button to start from the specified command.

You can also run the program from the beginning by pressing the (5) button.

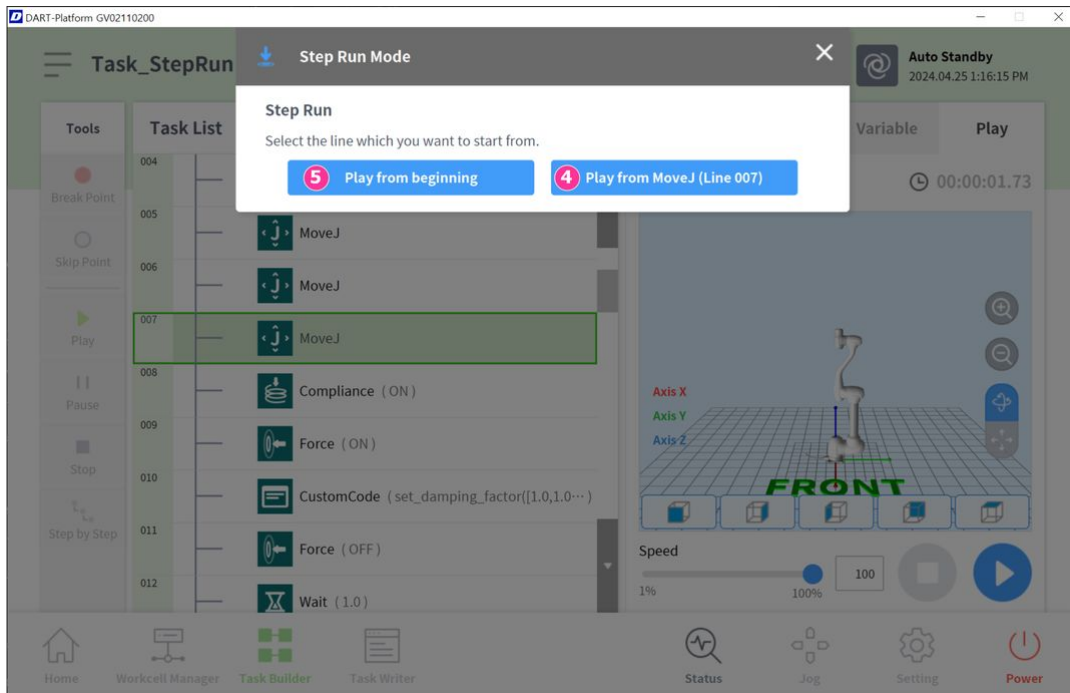

6. Check the program run after selecting to start from specified line.(6)

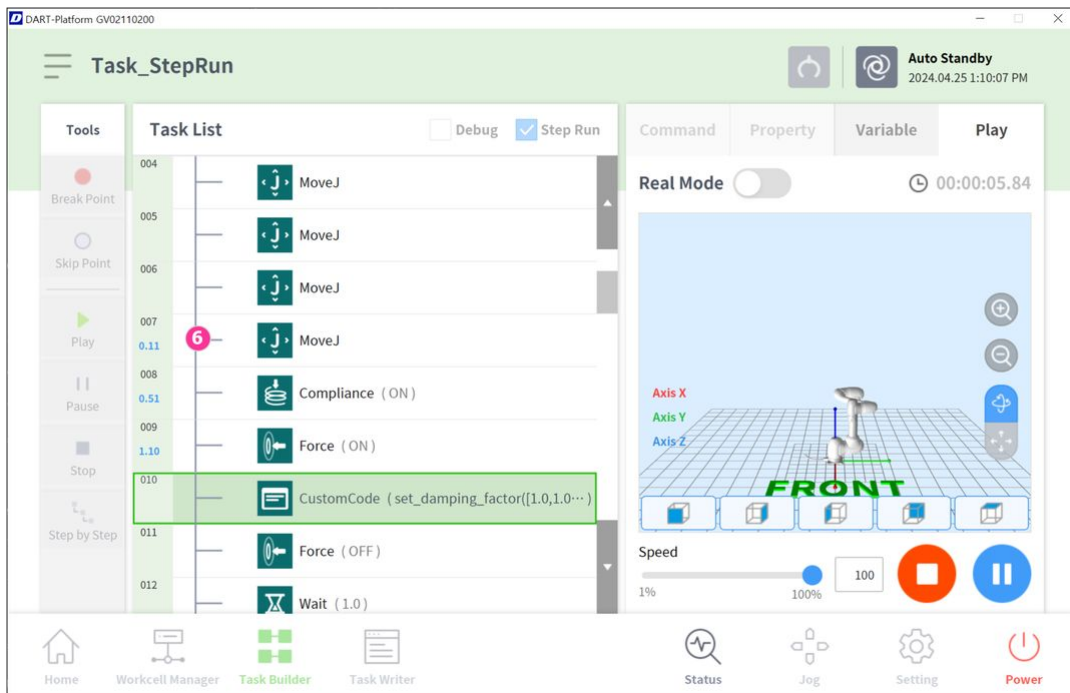

2.5.10 Try force command samples

OPTIONAL **NORMAL** 20 MIN



Sorry, the widget is not supported in this export.
But you can reach it using the following URL:
<https://www.youtube.com/watch?v=yza47Fvj0xo>

This sample is created in the Task Writer. This sample can be tried almost the same way in the Task Builder.

⚠ Caution

Before trying the sample, make sure to read and follow [Precautions for Use](#)(p. 11). For more information, refer to [PART 1. Safety Manual](#)(p. 9).

i This sample requires the Task Writer file created in [Try Compliance command samples](#)(p. 131).

1. [Try Compliance command samples](#)(p. 131) Open the created Task Writer file and select the compliance command on the fourth line of the task list.
2. Select the Property tab.
3. Set the mode as the following: Mode On enables compliance control. Force command is available only when compliance control is enabled.
 - Mode: On
4. Set the default stiffness value as the following:
 - a. X, Y, Z: 3000 N/m (default)
 - b. Rx, Ry, Rz: 200 Nm/rad (default)
5. Press the Confirm button.
6. Select the Command tab.
7. Add a force command. This command is planned to be used for enabling force control.

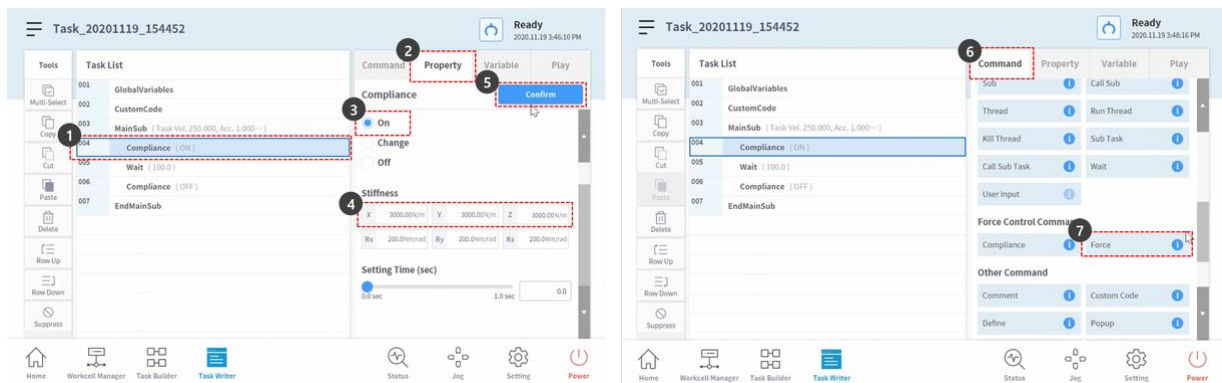

8. Select the sixth line of the task list.
9. Add a force command. This command is planned to be used for disabling force control.
10. Select the force command from the fifth line of the task list.
11. Select the Property tab.
12. Set the mode as the following: Mode On enables Force Control.
 - Mode: On
13. Set the Desired Force as the following:
 - a. X: 0 N (default)
 - b. Y: 0 N (default)
 - c. Z: -10 N
 - d. Rx, Ry, Rz: 200 Nm/rad (default)
14. Only check Z-axis in the Target Direction.
15. Press the Confirm button.

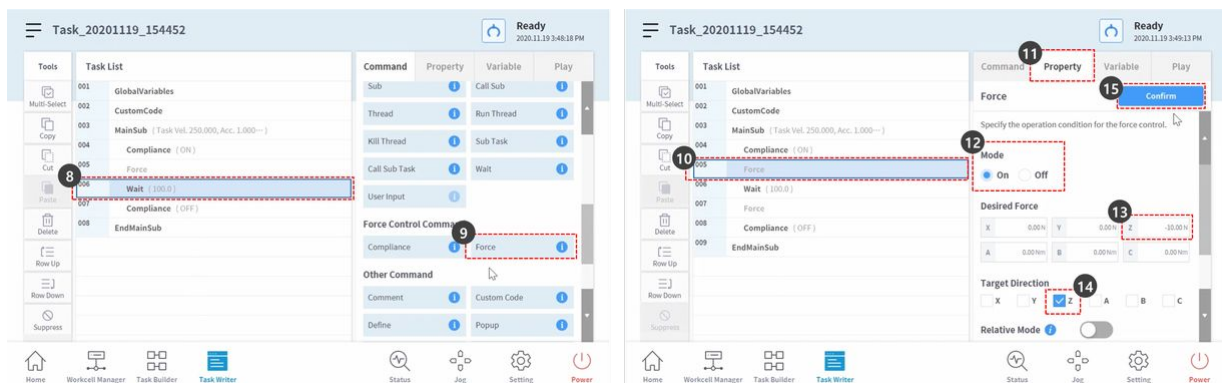

16. Select the Force command from the seventh line of the task list.
17. Set the mode as the following: Mode Off disables Force Control.
 - Mode: Off
18. Press the Confirm button.
19. Select the Play tab.
20. Enable the Real Mode toggle button.
 - a. Once the toggle button becomes enabled, the button lights up green.

21. Check if the TCP force of each axis is 0. This force value is the size of external force currently applied on the robot end TCP.
22. Press the Play button.

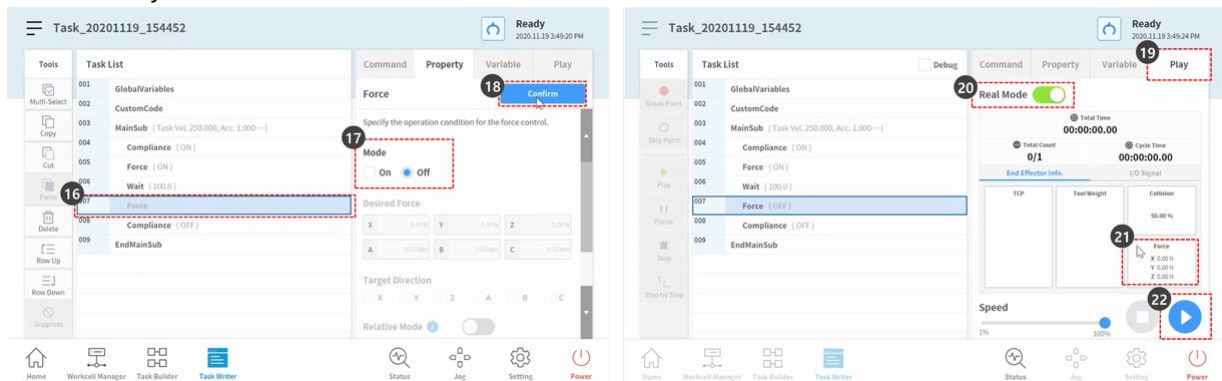

23. -10N of force is applied on the robot end TCP causing the robot to slowly move in the Z-axis direction.
24. The robot end repels the robot movement in +Z-axis direction, the opposite of the robot movement direction. When the force moving the robot and the force repelling robot movement reach a balance, the robot will maintain its position as if it stopped.
25. If a force greater than +10N is applied on the robot, the robot will comply with the force applied on the robot and move in the force direction.

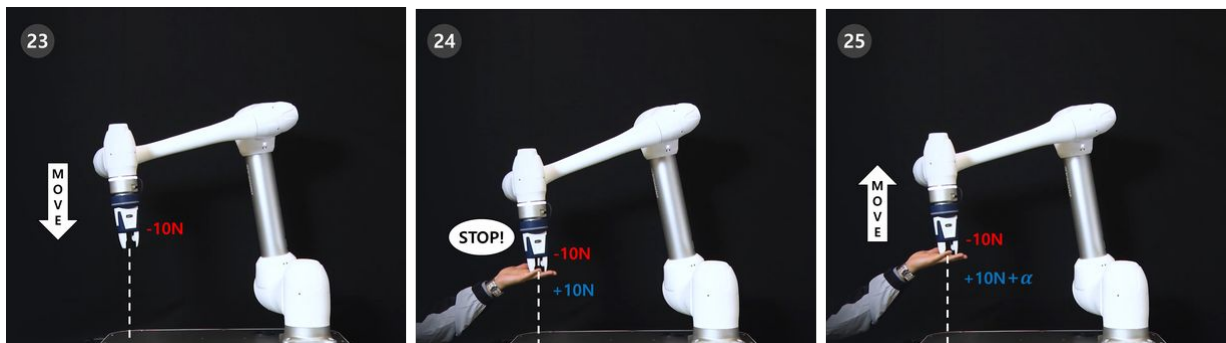

2.5.11 Register and manage variables

In Task Builder/Writer, variable, array and pose variables can be registered for use during program creation. There are three types of variables are supported which is System Variable, Global Variable and Define variable.

The variable types and their respective registration screens are as follows.

Variable type	Registration Screen	Reference screen image
System Variable	<ul style="list-style-type: none"> • Workcell Manager → System Variable tab • Task Builder/Writer → Variable tab → System Variable → Edit & Add 	
Global Variables	<ul style="list-style-type: none"> • Task Builder/Writer → GlobalVariables command → Property tab → Edit & Add 	
Define	<ul style="list-style-type: none"> • Task Builder/Writer → Add Define command → Property tab → Edit & Add 	

Depending on the use case, different variable types can be registered, and registration screens for each variable type provide the same functionality.

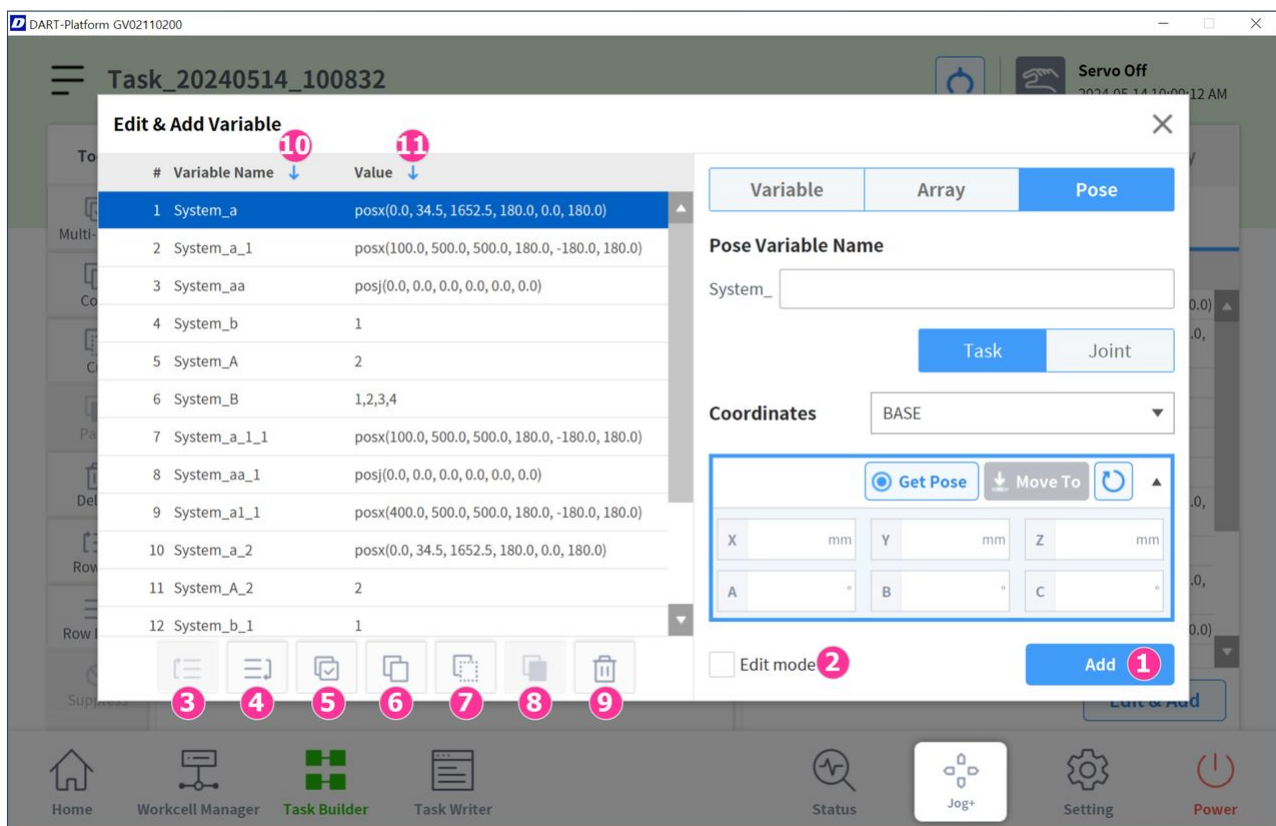

1. **Add new variable:** Select the variable option (Variable, Array, Pose) to register, enter the variable name and value, and click the "Add" button to register a new variable. The newly registered variable will be added to the end of the current list.
2. **Edit:** Select a registered variable and activate the Edit mode check box to modify the variable name and value. After making the changes, click the "Apply" button to apply the modifications. The edited variable will move to the end of the list after applying the changes.
3. **Row Up:** Move the selected variable's single row up by one line.
4. **Row Down:** Move the selected variable's single row down by one line.
5. **Multi-Select:** Select multiple variables at once and use them in conjunction with the copy, cut, and delete functions.
6. **Copy:** Copy the selected variables and temporarily save to the clipboard.
7. **Cut:** Cut the selected variables and temporarily save to the clipboard.
8. **Paste:** Paste the variables saved in the clipboard below the currently selected variable. In Task Builder/Writer, copying or cutting variables actions are allowed between different variable types.
9. **Delete:** Select the variables to delete from the variable list and click the Delete button to delete them.
10. **Sort by variable name:** Ascending order / Descending order / Clear sorting
 - An example of sorting in ascending order:

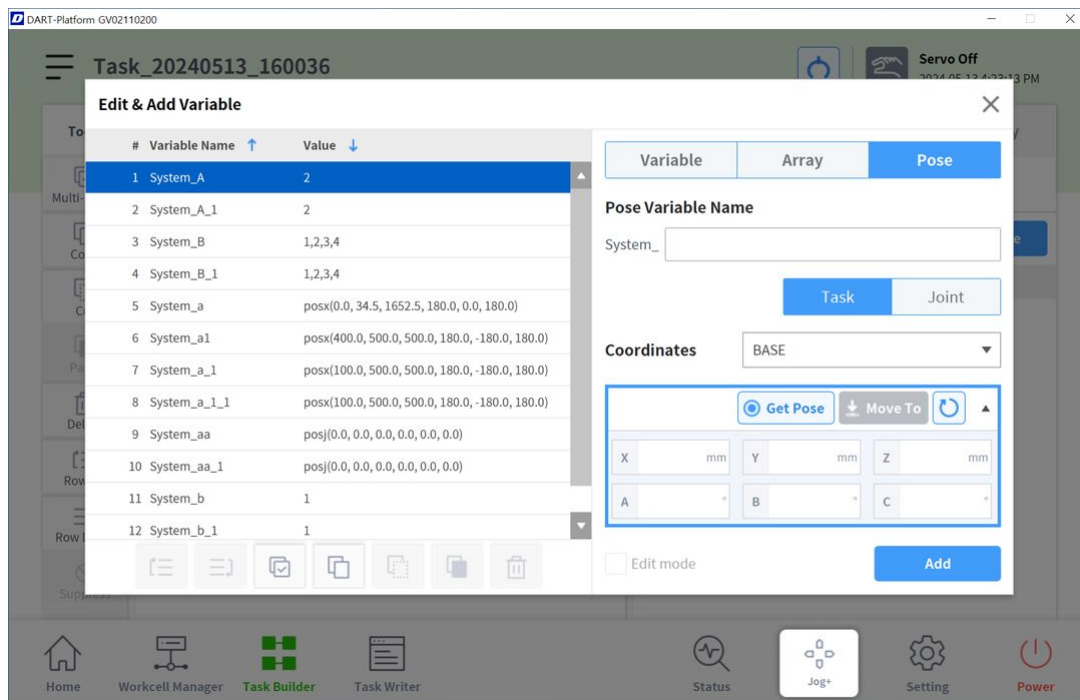

11. Sort by variable value: Variable value will be sorted by Type in Ascending order / Descending order / Clear sorting

- When sorted by variable value in ascending order, the order of variable types will be Variable → Array → Joint Pose → Task Pose.
- When sorted by variable value in descending order, the order of variable types will be Task Pose → Joint Pose → Array → Variable
- An example of sorting in descending order by variable value:

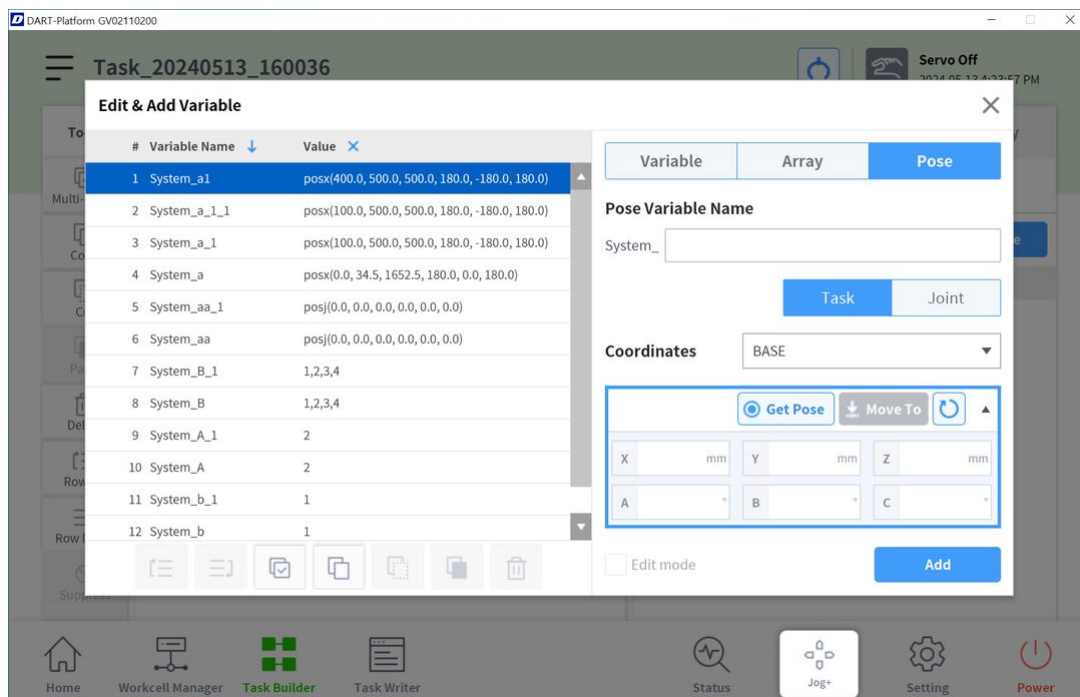

2.5.12 Utilize debugging

OPTIONAL **NORMAL** 5 MIN

The teach pendant offers debugging functions for task programs created using the Task Builder and Task Writer.

- Debugging refers to the process of removing bugs in the created code.
- The debugging function is a mandatory tool in finding and fixing bugs within an app.

This section describes the debugging screen, function and method of the Task Builder, but the same procedure can be used in the Task Writer.

Note

To execute the task and to perform debugging, the robot must be in Servo On state. Press the **Status > Servo On** button to set the robot to Servo On.

1. Open the task program to debug in the Task Builder.
2. Check whether the task list has the task to debug.
3. Select the Play tab on the screen right.
4. Select the Debug checkbox.

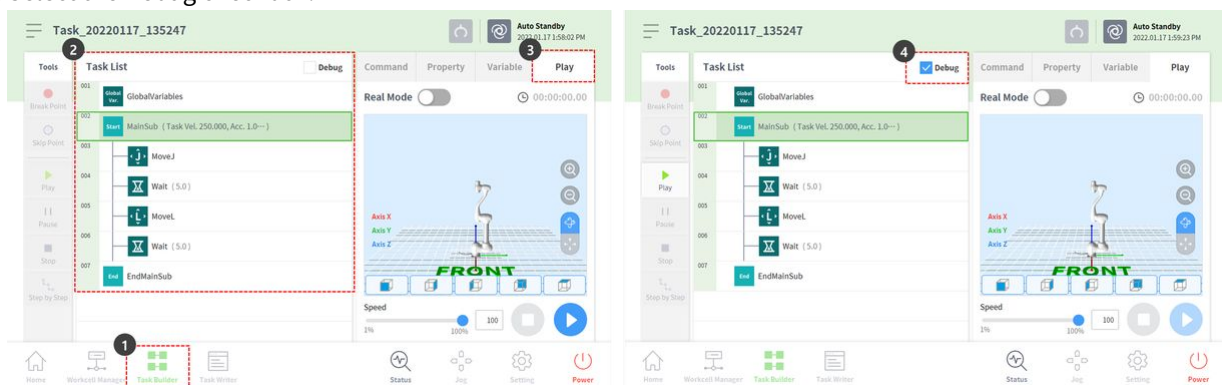

5. The Tools menu on the left offers the following debugging functions.
 - Break Point: It refers to the point where the program is deliberately stopped. The program will temporarily be stopped before executing the command in the selected command line.
 - Skip Point: It refers to the point where the program is deliberately skipped. The command of the selected line is not executed and the command in the next line is executed.
 - Play: It is the button that executes debugging, and it has the same function as the button executing programs. The difference is that executing debugging will activate break points and skip points.
6. Select the command line to debug and press the Break Point button to add a break point.
7. The break point will stop before executing the command in the corresponding point when debugging is executed by pressing the Tools > Play button. During pause, the Tools menu on the left offers the following debugging functions.
 - Resume: Continues the execution of the paused command from the corresponding command line.
 - Stop: Ends the program debugging.

- Step by Step: Executes the single line of the paused command. The command is paused again in the next command line.
8. Once debugging is complete, modify command or property tab items requiring fixes, and execute debugging again.



2.5.13 Function of Operator Intervention

If a problem occurs while the robot is operating or a user issues a command, the robot stops operating and displays a pop-up message allowing the operator to intervene and resolve the situation. After the user resolves the problem, the task continues on the program line where the problem occurred.

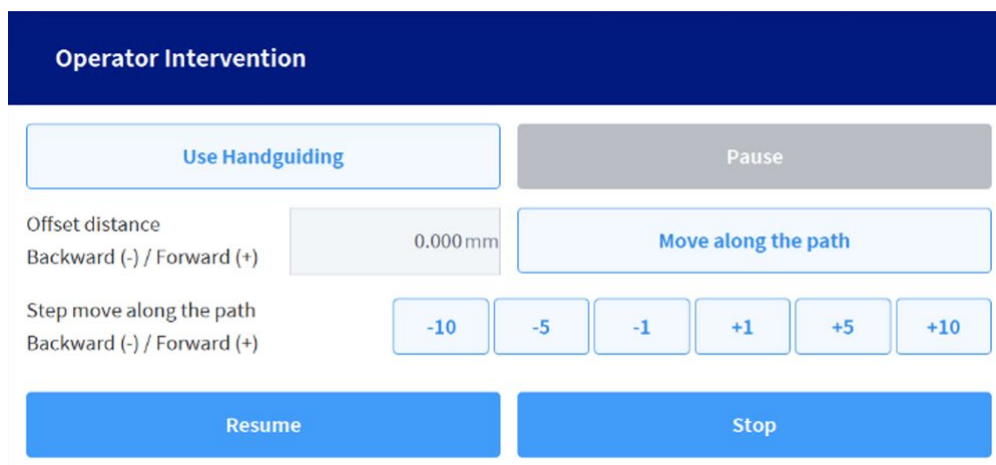

Note

- To use the worker intervention feature, you must complete one of the settings below.
 - Workcell Manager - Normal I/O - Input - Request Intervention (F)

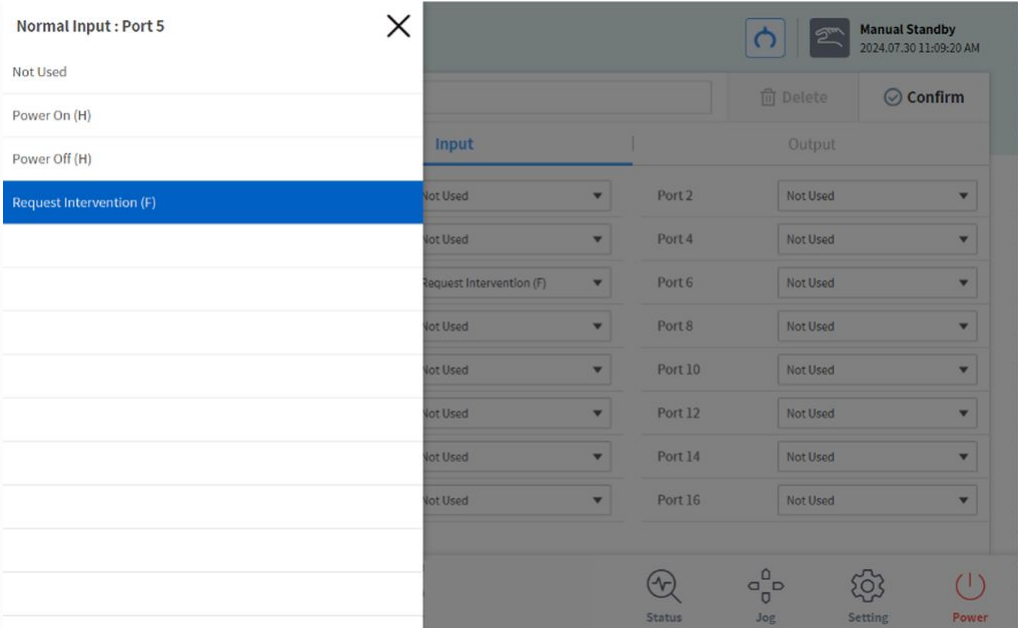

- Workcell Manager - Peripheral - Analog Welding Machine - Welding Input Signal (For detailed settings, refer to the Welding Technical Note.)

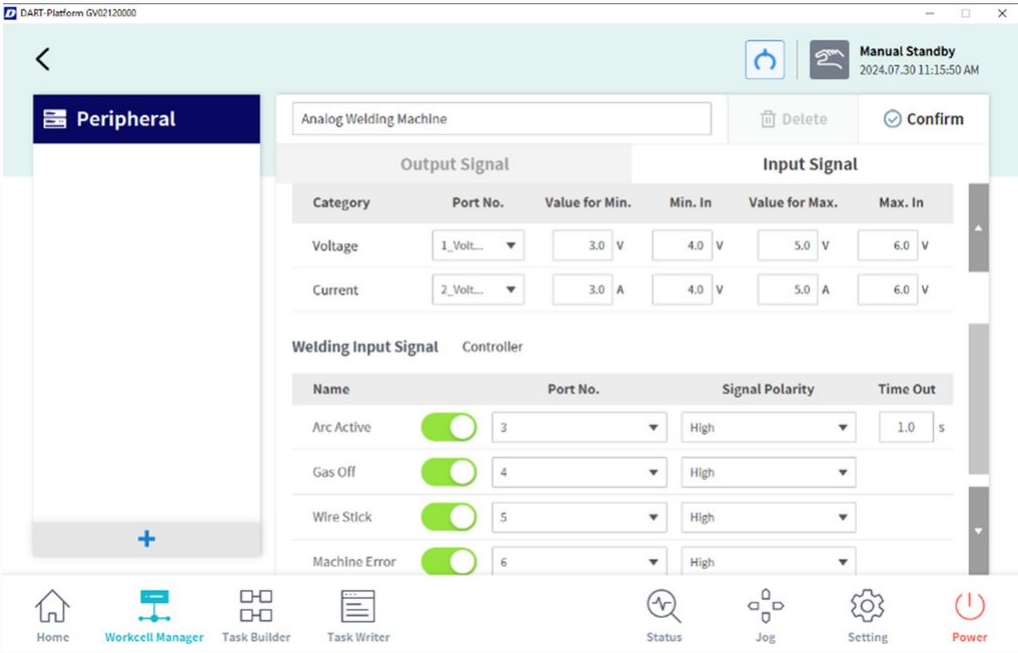

- The “Move along the path button” and the “Step Move button (-10,-5,-1,+1,+5,+10)” perform the same action. However, the former moves forward or backward from the reference position by a manually entered Offset, while the latter targets a point forward or backward by a preset Step Offset. After completing an action using the above buttons, pressing an additional button will move the current position by the Offset.

- The **“Use Handguiding button”** is activated only when a Collaborative Zone is set, and the robot state changes to the Handguiding state, which allows direct teaching within the Zone. After that, you can activate direct teaching by pressing the button on the back of the cockpit or the Teaching pendant.
- In handguiding mode, the **“Use Handguiding button”** changes to the **“End Handguiding button”**.
- When you press the **“End Handguiding button”**, the handguiding state ends. At this time, for safety reasons, the current robot position, angle, and the values of the stop point (the time when the first pop-up occurs) are compared to generate a pop-up. If a pop-up with the following contents occurs, you must teach again directly to correct the robot’s position and posture and try again.
 - If the straight-line distance between the current TCP position and the TCP at the stop position differs by more than 20 cm
 - If the difference between the current Joint Angle and the Joint Angle at the stop point differs by more than 1~3 axes (10 degrees) / 4~5 axes (30 degrees) / 6 axes (60 degrees)
- This feature is supported only during **MoveL / MoveC / MoveB** operations.
- You can use the Normal Output function to signal that a popup has occurred. The signal will remain active while the popup is occurring, and will be deactivated when the popup ends.
 - Workcell Manager - Normal I/O - Output - Operator Intervention (L)

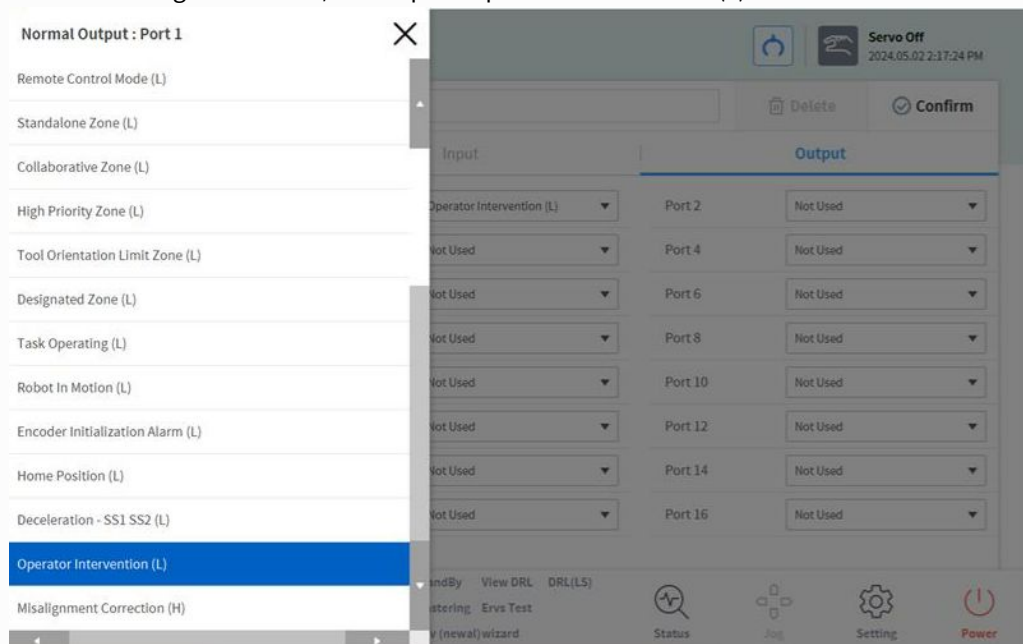

Here is the usage scenario:

1. Receive a digital input signal from the user or a connected device while the program is running.
2. The robot pauses and an operator intervention pop-up appears.

3. (If using direct teaching) Press the Use Handguiding button, then press the button on the back of the cockpit or teaching pendant to activate direct teaching. After the direct teaching operation is complete, press the End Handguiding button.
4. Press the Move along the path button to move the robot along the path.
5. After moving the robot as much as desired, press the Resume button to resume the robot's task and close the pop-up.

3 PART 3. Installation Manual

The installation manual describes how to install the robot and controller, as well as their specifications.

3.1 Product Introduction

3.1.1 Component Check

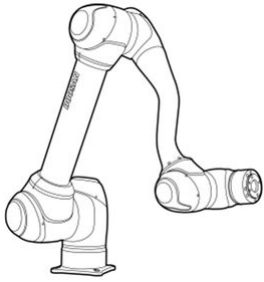
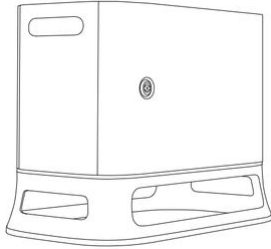
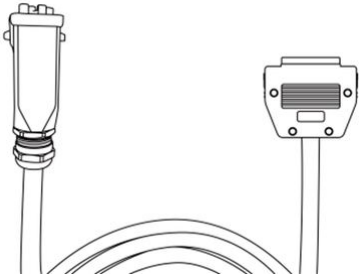
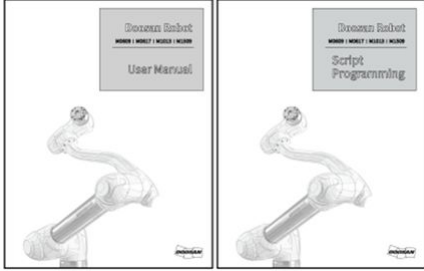
	
<p>Manipulator</p>	<p>Controller (Option : Refer to Appendix)</p>
	
<p>Teach pendant</p>	<p>Controller power supply cable</p>
	
<p>Manipulator connection cable</p>	<p>User manual / Quick guide</p>
<p>Note</p> <ul style="list-style-type: none"> • Components may vary depending on the robot model. 	

- Robots manufactured after 2025.01.01 must use software (version v2.12 or later) that reflects some changes to the mechanical part.

3.1.2 Names and functions of each part

Manipulator

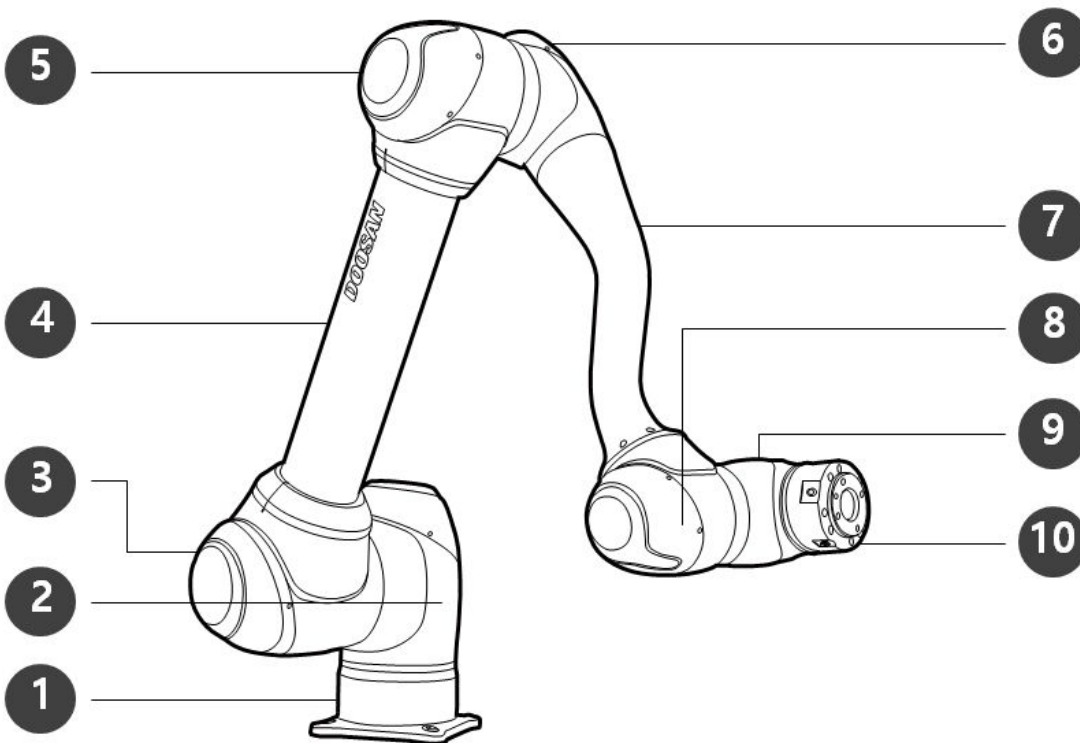

Names of Parts

No.	Name	No.	Name
1	Base	6	J4
2	J1	7	Link2
3	J2	8	J5
4	Link1	9	J6
5	J3	10	Tool Flange

Key Features

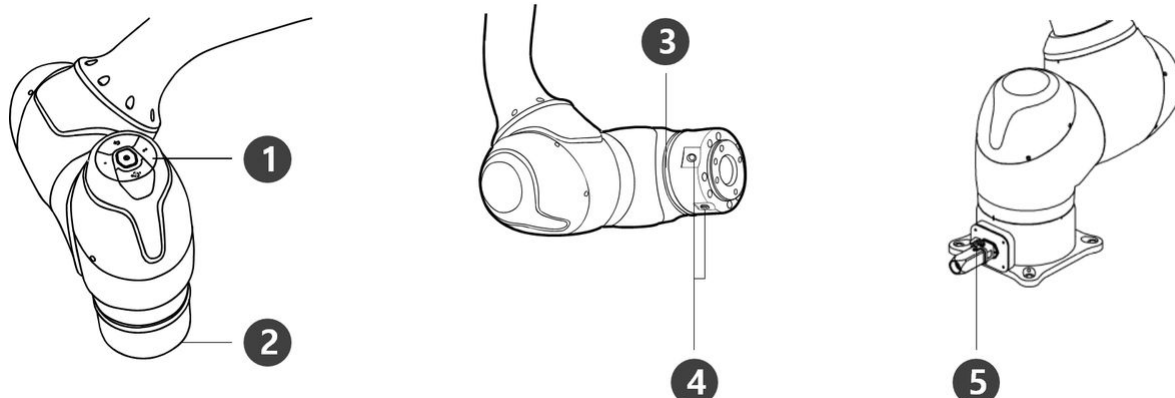

No.	Item	Description
1	Cockpit	[Option] Controller used for direct teaching and operation.
2	Tool Flange	Area to install tools.
3	Flange LED	Displays the robot state with different colors. For more information about robot state, refer to Status and Flange LED Color for Each Mode (p. 16). <div style="border: 1px solid black; padding: 5px; margin-top: 10px;"> <p>i Version : H Series For H-Series, an additional LED is installed on the 1 axis to indicate the same status and color.</p> </div>
4	Flange I/O	I/O port for tool control. (Digital input 3ch, output 3ch)
5	Connector	Used for supplying power to and communication of the robot.

Controller

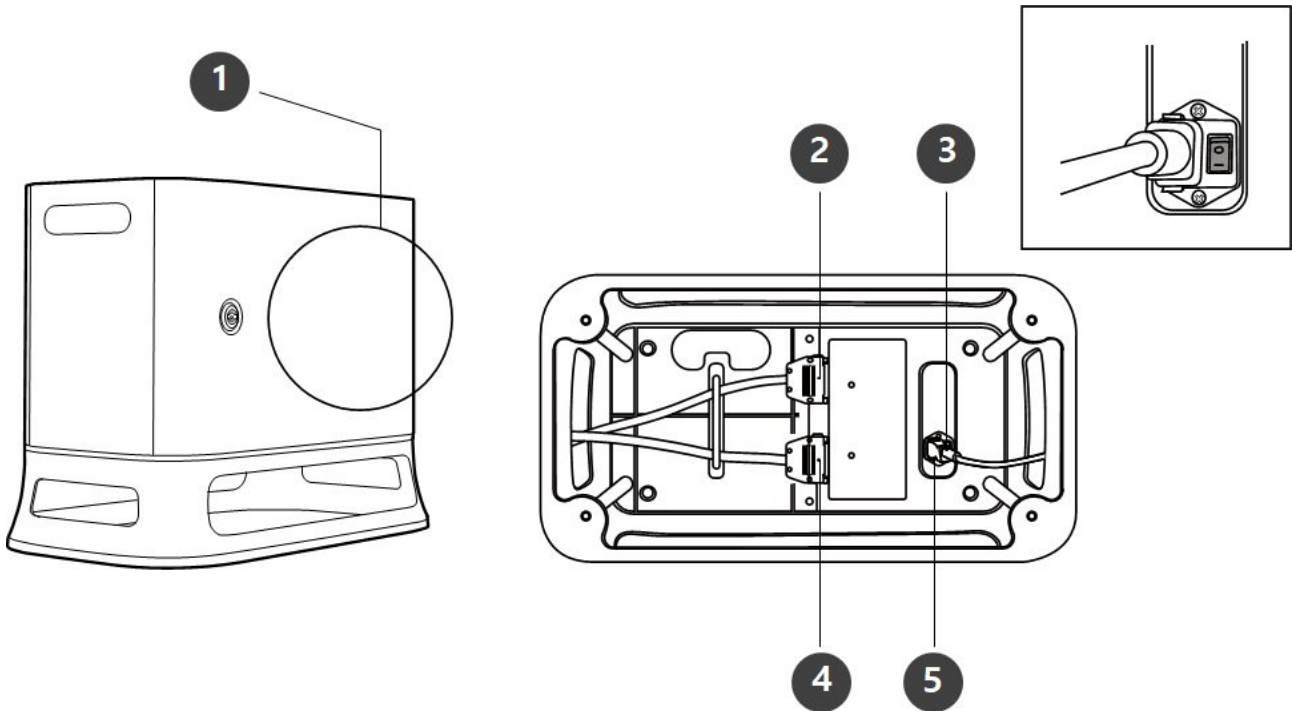

No.	Item	Description
1	I/O connection terminal (internal)	Used to connect the controller or peripherals.
2	Teach pendant cable connection terminal	Used to connect the teach pendant cable with the controller.
3	Power switch	Used to turn ON/OFF the main power of the controller.
4	Manipulator cable connection terminal	Used to connect the manipulator cable to the controller.
5	Power connection terminal	Used to connect the controller power supply.



Note

If you selected an optional controller, check the instructions in the appendix to connect cables.

Teach pendant



A Series

Teach Pendant must be purchased separately as an optional product rather than as a basic component

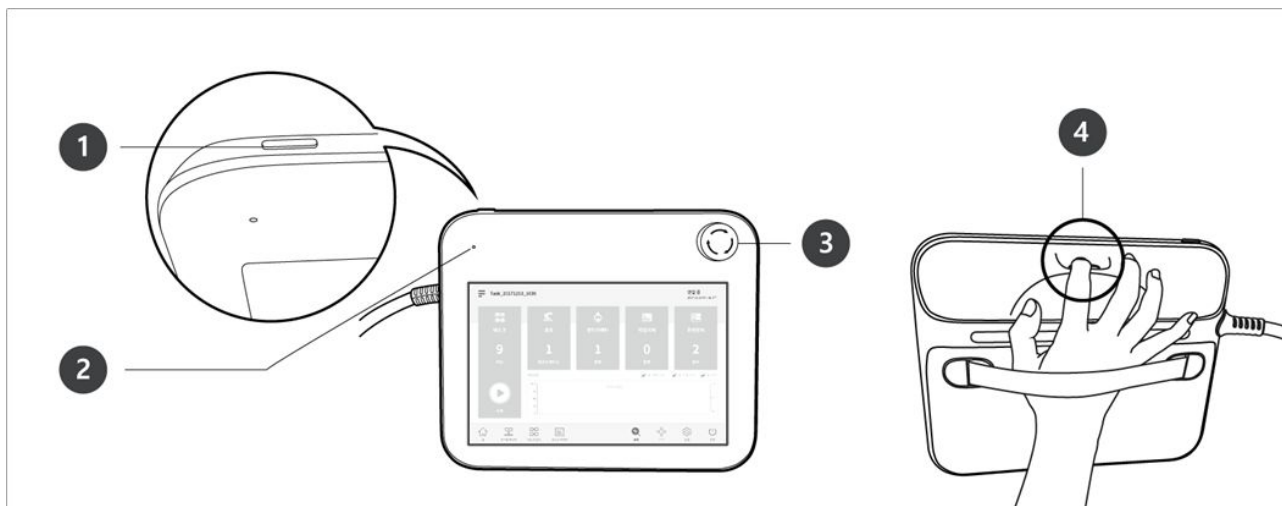

No.	Item	Description
1	Power button	Used to turn ON/OFF the main power of the teach pendant. For detailed product features, please refer to System Power On/Off(p. 223) .
2	Power LED	Turns ON when power is supplied.
3	Emergency stop button	Press the button to stop robot operation in case of an emergency.
4	Hand guiding button	Press and hold the button to move the robot freely into a desired pose.

Note

If you need to protect and hold the Teach Pendant during work, you can use it more safely and easily with a soft cover supplied by Doosan Robotics.

3.1.3 System Configuration

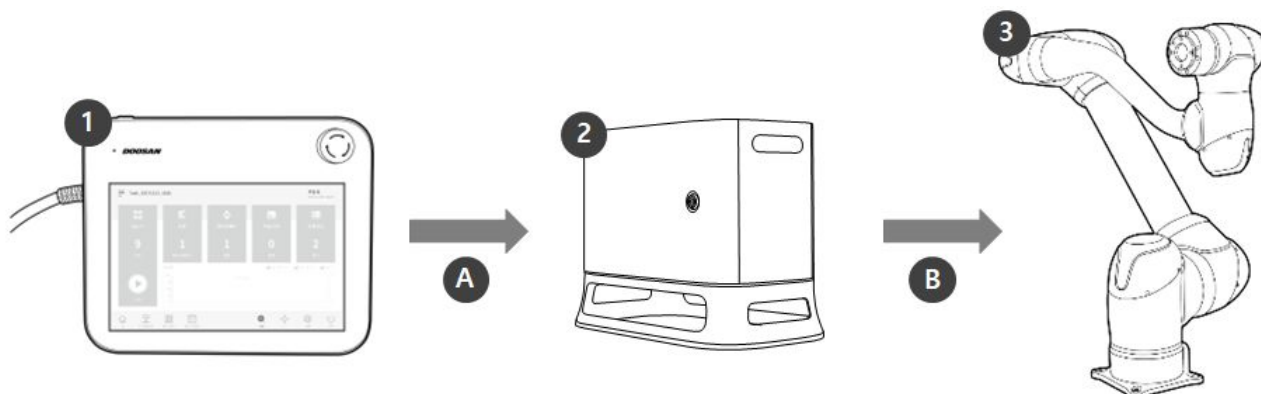

No.	Name	Description
1	Teach pendant	It is a device that manages the overall system, and it is capable of teaching the robot specific poses and setting manipulator and controller related settings.
2	Controller	It controls the robot's movement according to the pose or movement set by the teach pendant. It features various I/O ports that allow the connection and use of various equipment and devices.
3	Manipulator	It is an industrial collaborative robot that can perform transport or assembly tasks with various tools.
A	Command/ Monitoring	
B	Power Supply/ Network	

Note

- Refer to the robot system configurations of the M Series and H Series below.

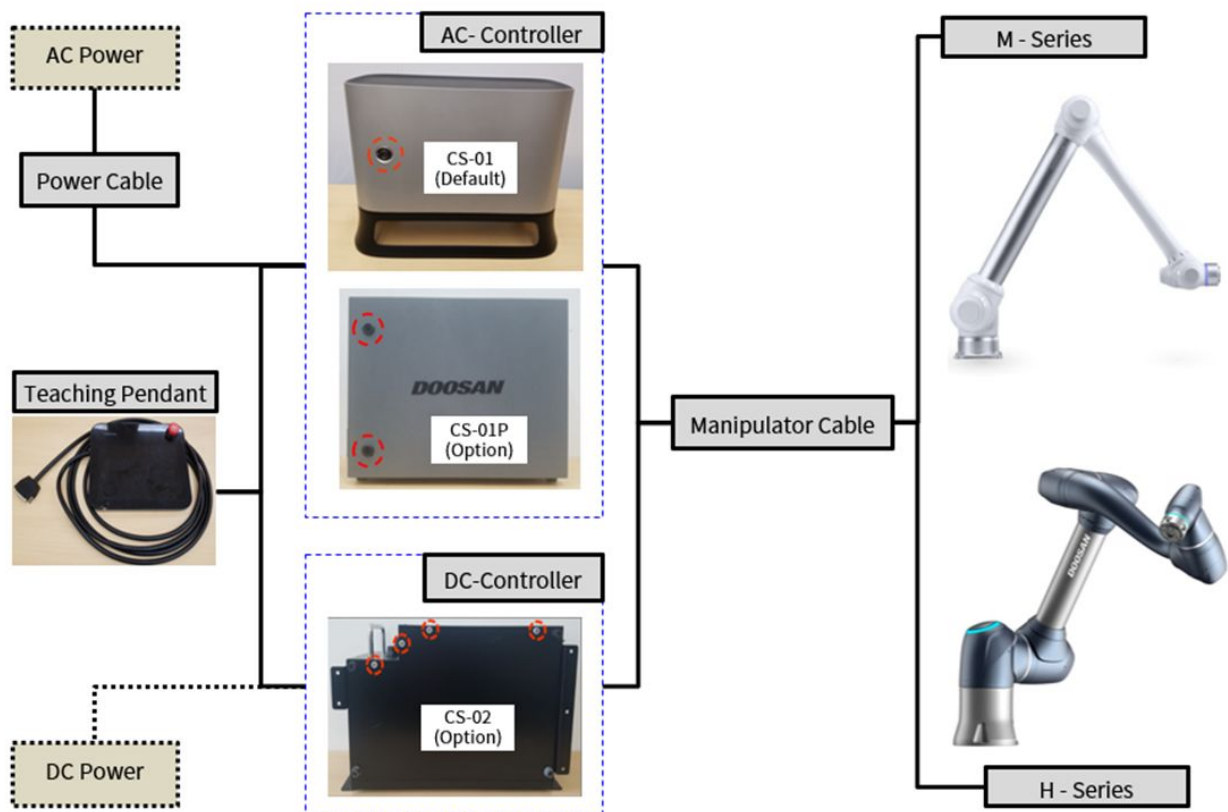

3.1.4 Product Specifications, General

M Series	Technical Data
M0609	Refer to M0609 (p. 375).
M0617	Refer to M0617 (p. 378).
M1013	Refer to M1013 (p. 377).
M1509	Refer to M1509 (p. 376).
H Series	Technical Data
H2017	Refer to H2017 (p. 380).
H2515	Refer to H2515 (p. 381).

3.1.5 Robot Specifications

Axis Specification

Model Name	M0609	M0617	M1013	M1509	H2017	H2515
Operating Angle						
J1	±360° (TP: ±360°)	±360° (TP: ±360°)	±360° (TP: ±360°)	±360° (TP: ±360°)	±360° (TP: ±360°)	±360° (TP: ±360°)
J2	±360° (TP: ±95°)	±360° (TP: ±95°)	±360° (TP: ±95°)	±360° (TP: ±95°)	±125° (TP: ±95°)	±125° (TP: ±95°)
J3	±150° (TP: ±125°)	±165° (TP: ±145°)	±160° (TP: ±135°)	±150° (TP: ±125°)	±160° (TP: ±135°)	±160° (TP: ±135°)
J4	±360° (TP: ±360°)	±360° (TP: ±360°)	±360° (TP: ±360°)	±360° (TP: ±360°)	±360° (TP: ±360°)	±360° (TP: ±360°)
J5	±360° (TP: ±135°)	±360° (TP: ±135°)	±360° (TP: ±135°)	±360° (TP: ±135°)	±360° (TP: ±135°)	±360° (TP: ±135°)

Model Name	M0609	M0617	M1013	M1509	H2017	H2515
J6	±360° (TP: ±360°)	±360° (TP: ±360°)	±360° (TP: ±360°)	±360° (TP: ±360°)	±360° (TP: ±360°)	±360° (TP: ±360°)
Max. Speed per Axis (rated payload operation)						
J1	150 °/s	100 °/s	120 °/s	150 °/s	100 °/s	100 °/s
J2	150 °/s	100 °/s	120 °/s	150 °/s	80 °/s	80 °/s
J3	180 °/s	150 °/s	180 °/s	180 °/s	100 °/s	100 °/s
J4	225 °/s	225 °/s	225 °/s	225 °/s	180 °/s	180 °/s
J5	225 °/s	225 °/s	225 °/s	225 °/s	180 °/s	180 °/s
J6	225 °/s	225 °/s	225 °/s	225 °/s	180 °/s	180 °/s

Robot operating space

M0609

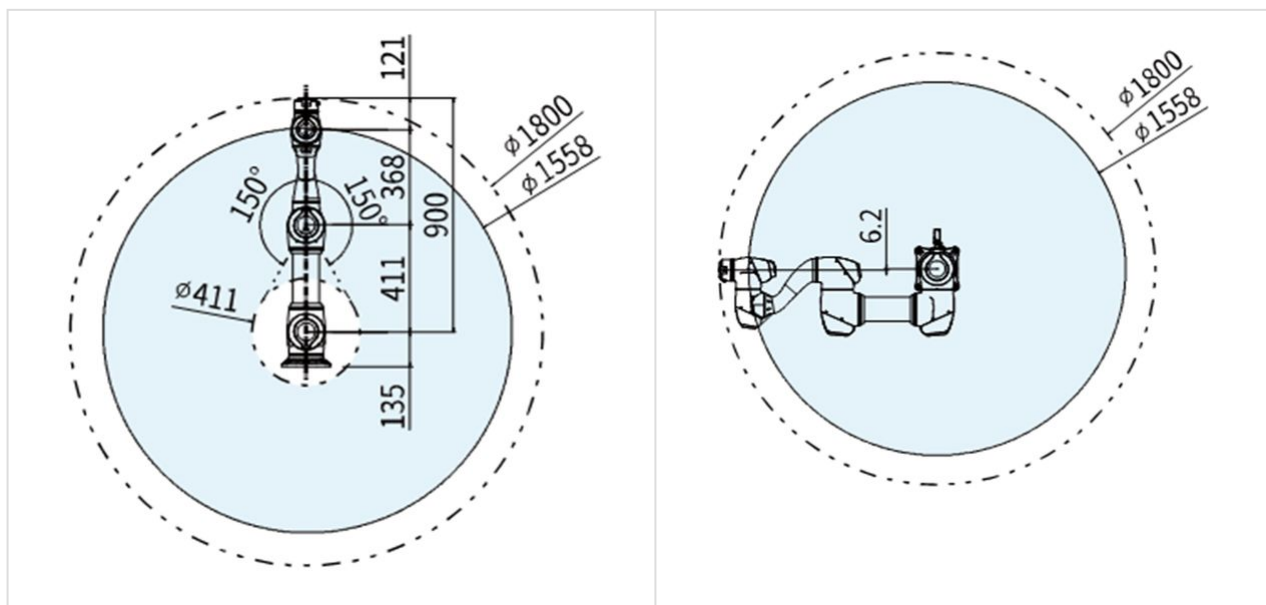

M0617

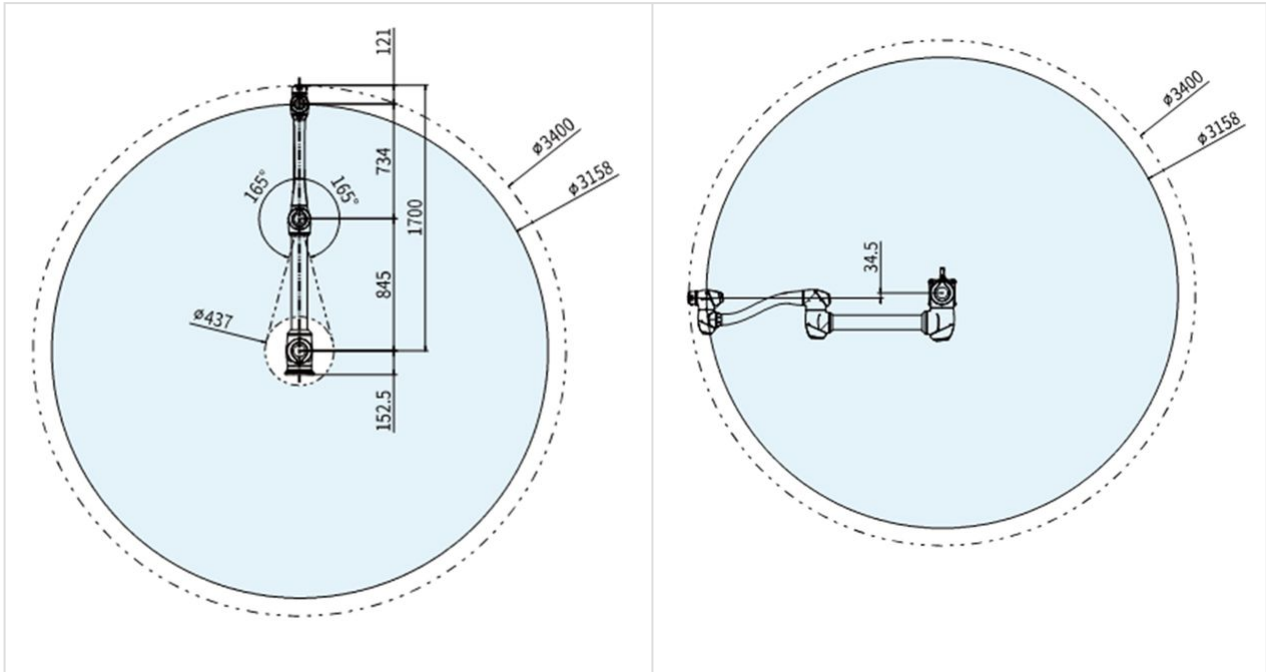

M1013

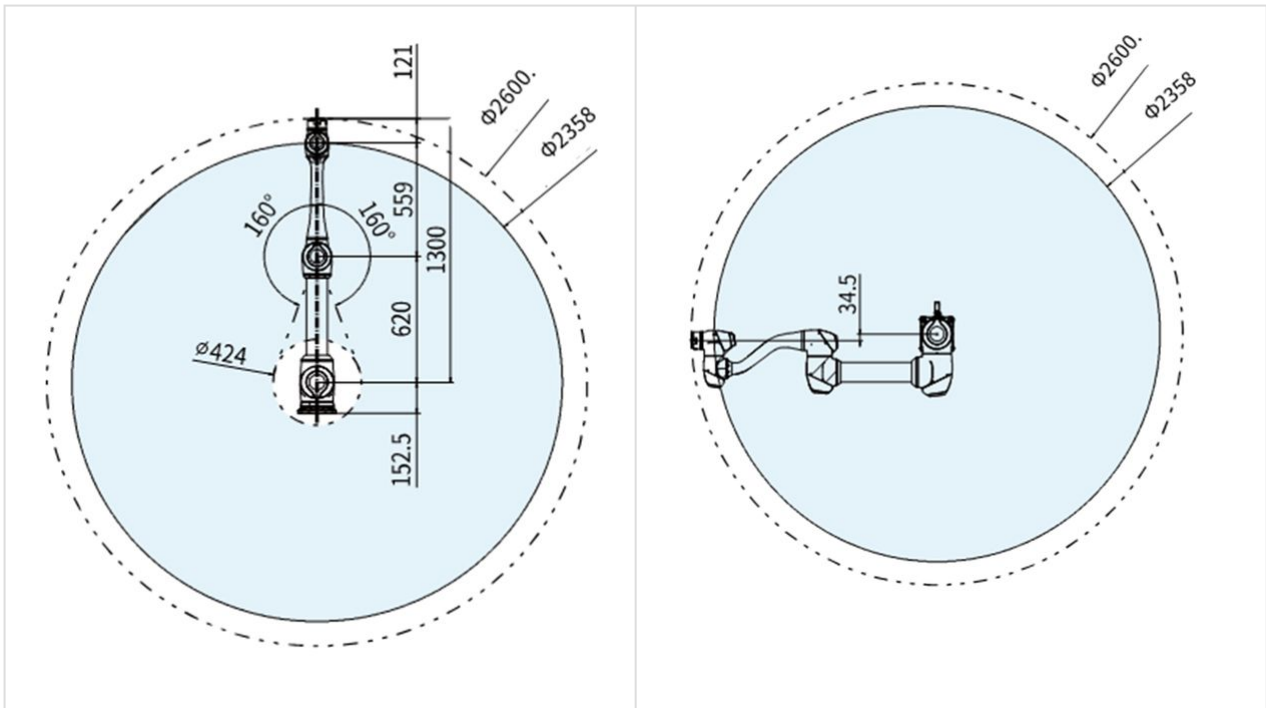

M1509

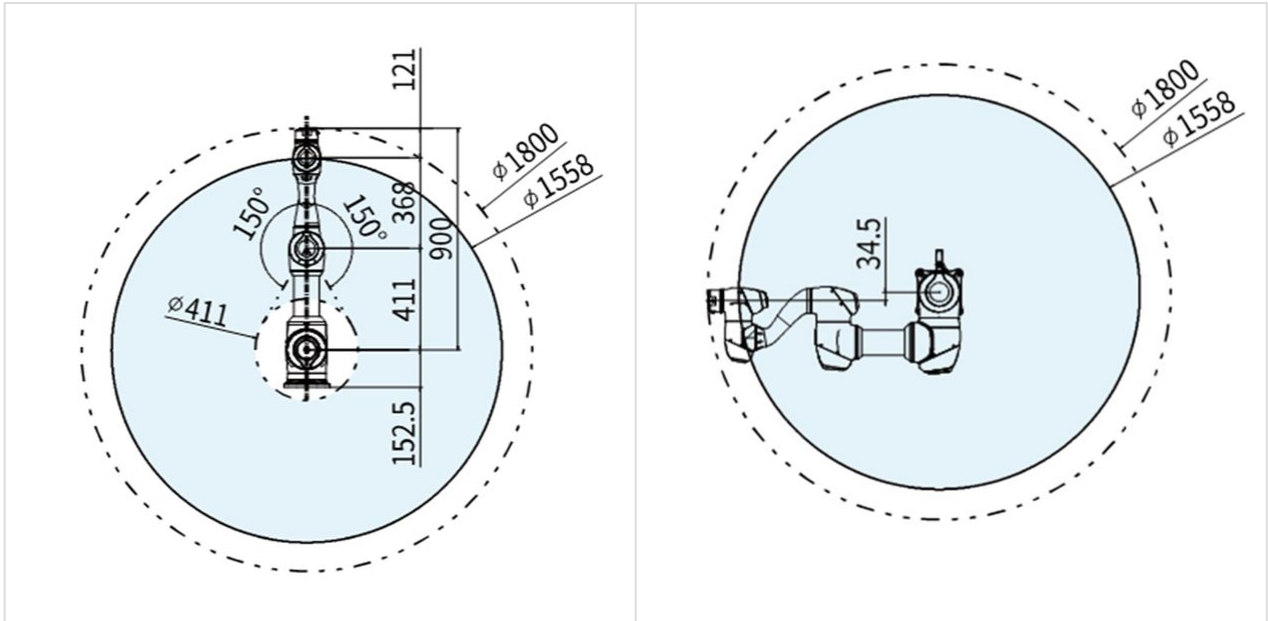

H2017

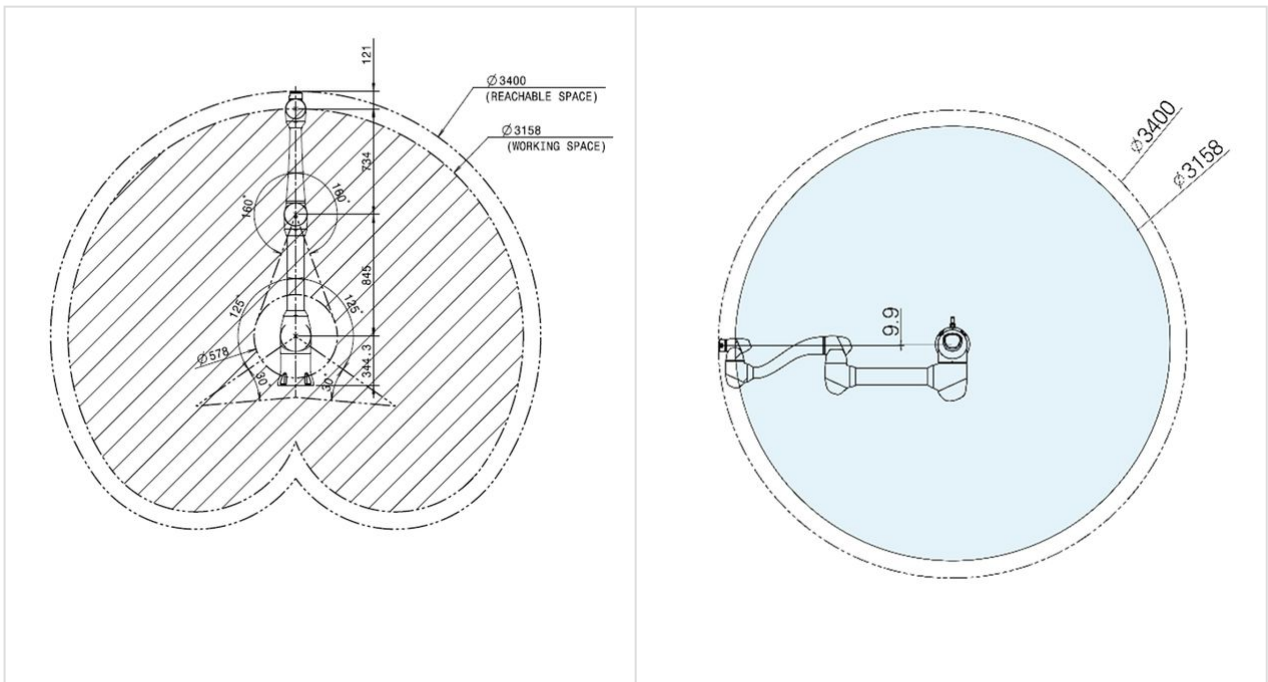

H2515

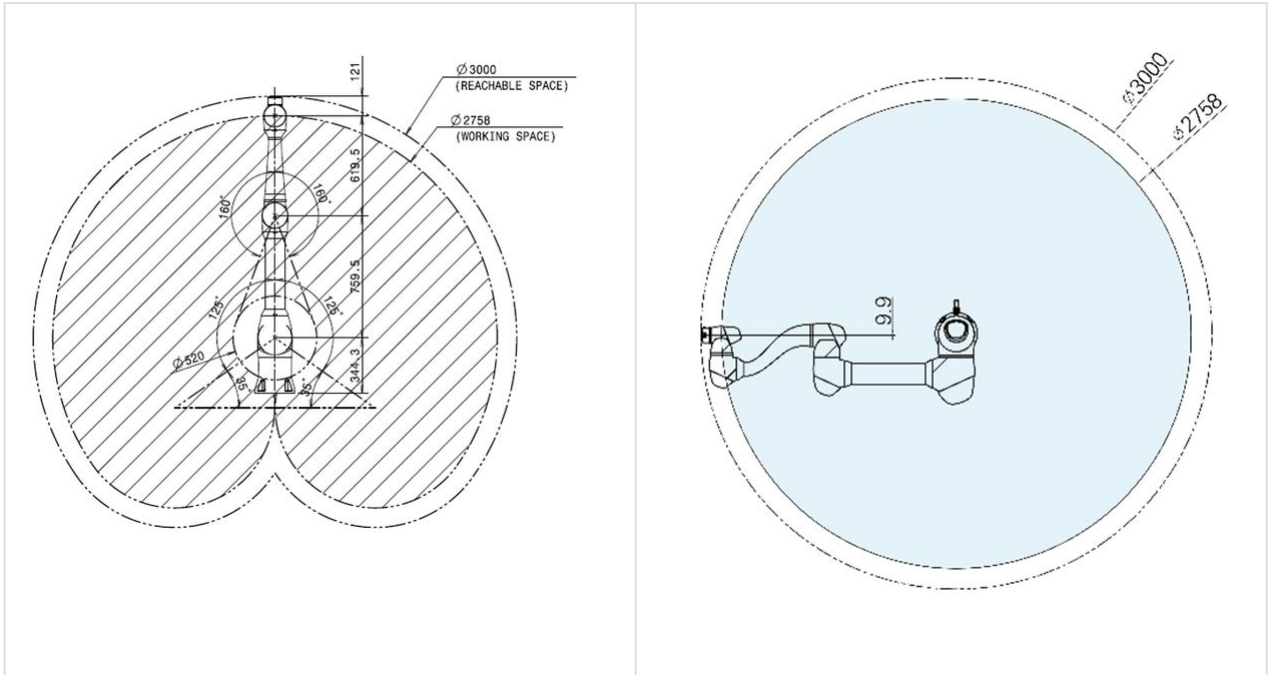

Max. Payload within operating space

The maximum payload of the robot within its operating space changes according to the distance from the center of gravity. Payload per distance is as follows:

Note

This load diagram assumes a small tool load volume. Tools with a larger volume will have greater limitations in payload above the tool's center of gravity compared to a tool with an equal weight but smaller volume, and in such cases, vibration may occur.

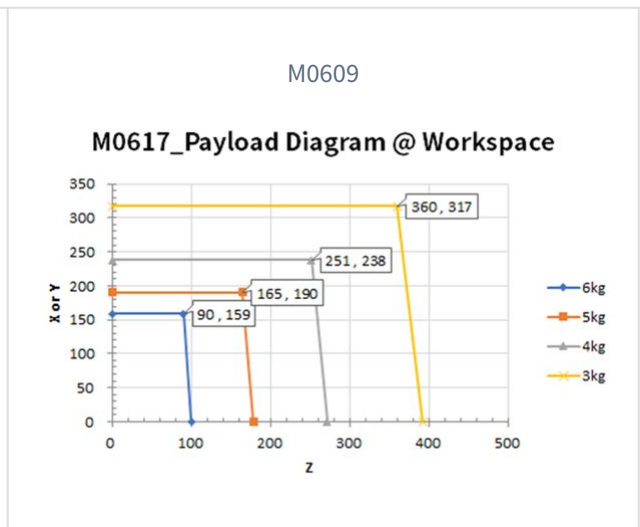
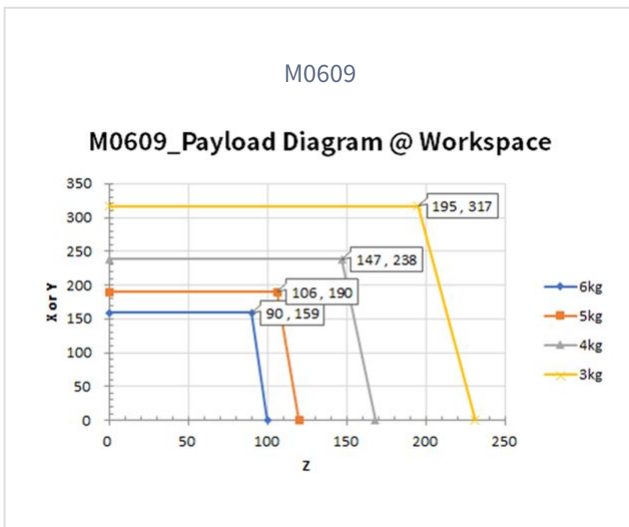

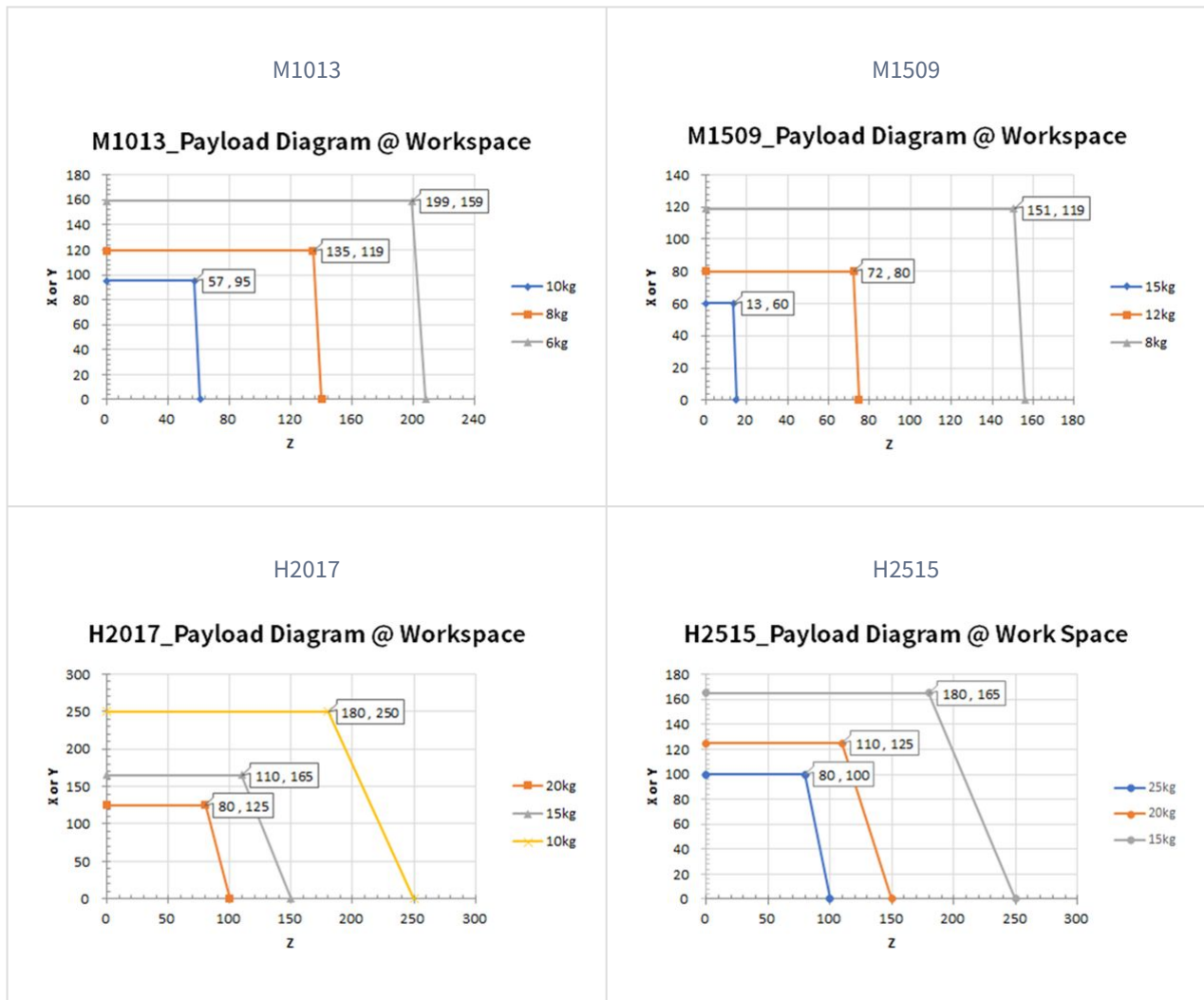

Allowed Moment and Inertia

The allowed moment and inertia for the J4-J6 robot are as follows:

Model Name	J4		J5		J6	
	Allowed Moment	Inertia	Allowed Moment	Inertia	Allowed Moment	Inertia
M0609	36 Nm	1.6 kgm ²	36 Nm	1.6 kgm ²	36 Nm	1.6 kgm ²
M0617						
M1013						
M1509						

Model Name	J4		J5		J6	
	Allowed Moment	Inertia	Allowed Moment	Inertia	Allowed Moment	Inertia
H2017	145 Nm	8.0 kgm ²	81Nm	4.5 kgm ²	36 Nm	2.0 kgm ²
H2515						

Tool Center Point (TCP)

Refer to the figure below for TCP.

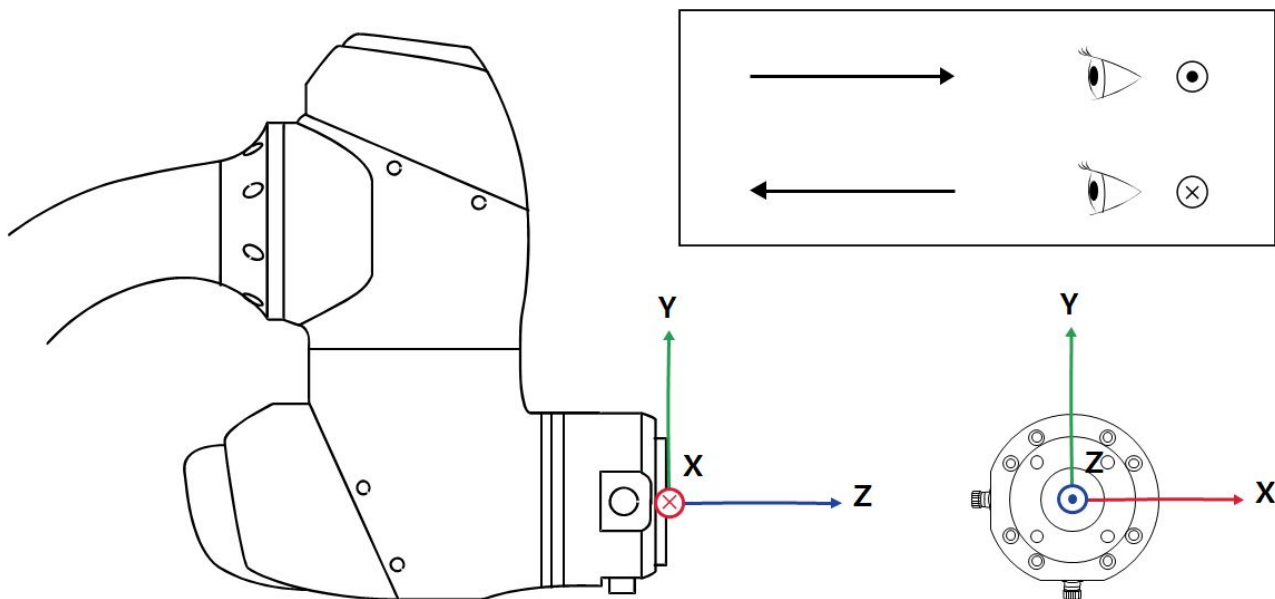

Basic specifications

Model Name	M0609	M0617	M1013	M1509	H2017	H2515
Weight	27 kg	34 kg	33 kg	32 kg	79 kg	77 kg
Payload within Work Radius	6 kg	6 kg	10 kg	15 kg	20 kg	25 kg
Max. Work Radius	900 mm	1700 mm	1300 mm	900 mm	1700mm	1500mm
Number of Axes	6					
Max. TCP Speed	1 m/s					

Model Name	M0609	M0617	M1013	M1509	H2017	H2515
Position Repeatability (ISO 9283)	±0.03 mm	±0.1 mm	±0.05 mm	±0.03 mm	±0.1 mm	
Protection Rating	IP 54					
Noise	< 65 dB					
Installation Direction	Any Orientation				Floor Only	
Controller and Teaching Pendant	Doosan Controller & Teach Pendant					
Vibration and Acceleration	10≤f<57Hz - 0.075mm amplitude 57≤f≤150Hz - 1G					
Impact	Max Amplitude : 50m/s ² (5G) * Time :30ms , Pluse : 3 of 3 (X,Y,Z)					
Operating Temperature	0 °C ~45 °C (273K to 318K)					
Storage Temperature	-5 °C ~50 °C (268K to 323K)					
Humidity	20%~80%					



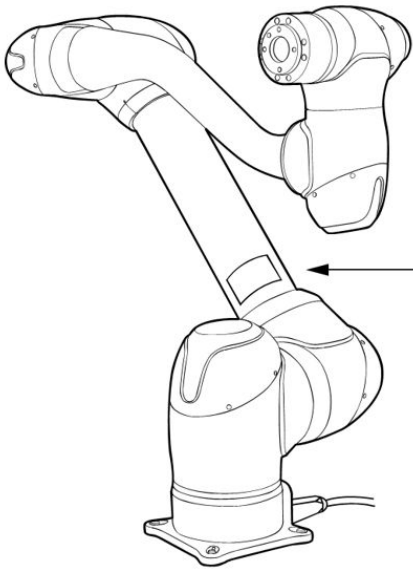

3.1.6 Nameplate and Label

Be careful not to remove or damage labels attached to the robot and controller.



DOOSAN

Doosan Robotics
 79, Saneop-ro 156beon-gil, Gwonseon-gu, Suwon-si, Gyeonggi-do, 16648, Republic of Korea
 www.doosanrobotics.com



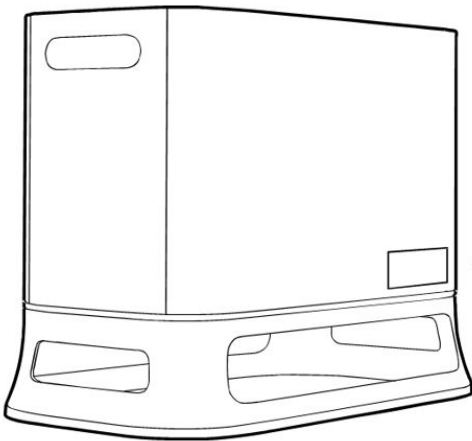

<p>Designation : Model No. : Serial No. : Reach : Weight : Input Voltage : Max. Payload : Mfg. Date :</p>	   
--	--

For lifting points for transport and installation, please refer to the **Quick Guide** or **User Manual**.



DOOSAN

Doosan Robotics
 79, Saneop-ro 156beon-gil, Gwonseon-gu, Suwon-si, Gyeonggi-do, 16648, Republic of Korea
 www.doosanrobotics.com

<p>Designation : Model No. : Drawing No. : Serial No. : Rated Voltage : Rated Current : Rated Frequency : S.C.C.R. : Weight : Mfg. Year & Month : Type :</p>	   
--	--

Note
 If you have selected an optional controller, please check the appendix as the label attachment location may vary.

3.2 Installation

3.2.1 Cautions during Installation

Warning



- Do not touch the power plug and power cable with wet hands when connect them to a power source. This can cause electrocution or injury. The maximum payload of the robot within its operating space changes according to the distance from the center of gravity. Refer to the tool center information provided in the manual.
- Secure sufficient space for installation before installing the robot. If not enough space is secured, the robot may be damaged or the user may be injured.
- Safety devices to be connected to the controller must be connected to a safety contact input terminal or a configurable digital I/O set to Safety I/O using dual signals. If safety devices are connected a regular I/O or are connected using single signals, the devices cannot satisfy the required safety level.
- partial equipment of supply disconnecting device changes according to the wiring location of plug and the installation environment of robot, so considering this, it must be installed so that it can be easily approached.
- For H-series, the robot can only be installed on the floor. To prevent safety accidents, consider the weight of the robot and refer to Handling Guide provided in this manual.
- For H-series, please install it in a location where the floor has a slope of 0.5 degrees or less.

Lifting points for transport and installation

- In order to prevent accidents, **be sure to check the local or national weight standards during material handling** and carry them in accordance with the guidelines.
- Please be careful of the accidents caused by falling while carrying the robot.

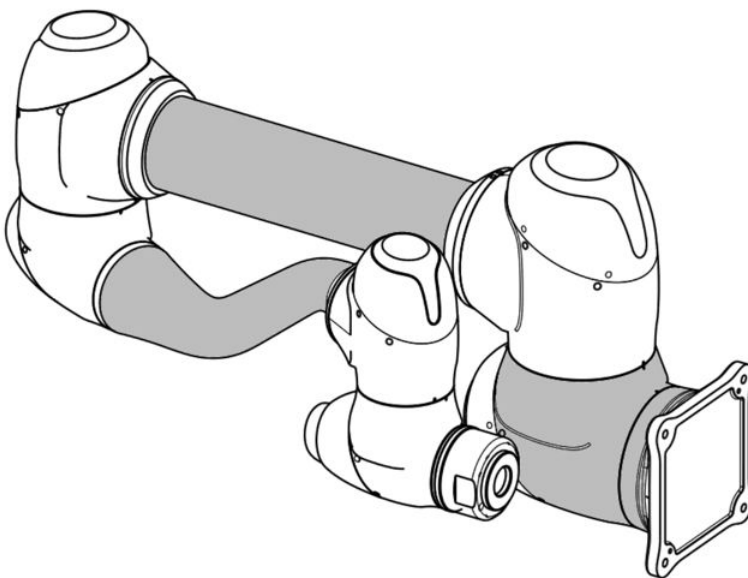

3.2.2 Installation Environment

Secure sufficient space to allow the robot to move freely. Check the operating space of the robot to ensure that the robot does not collide with external elements.

Installation Location Check

Before installing the robot, secure sufficient space and consider the following:

- Install the robot on a firm, even surface.
- Install the robot in a location with no water leakage and constant temperature and humidity.
- Check whether there are flammable and explosive materials near the installation location.

Caution



Installing the robot in locations other than the recommended locations may result in reduced robot performance and product life.

Robot Work Area Check

Secure installation space considering the operating space of the robot. The operating space varies according to the robot model.

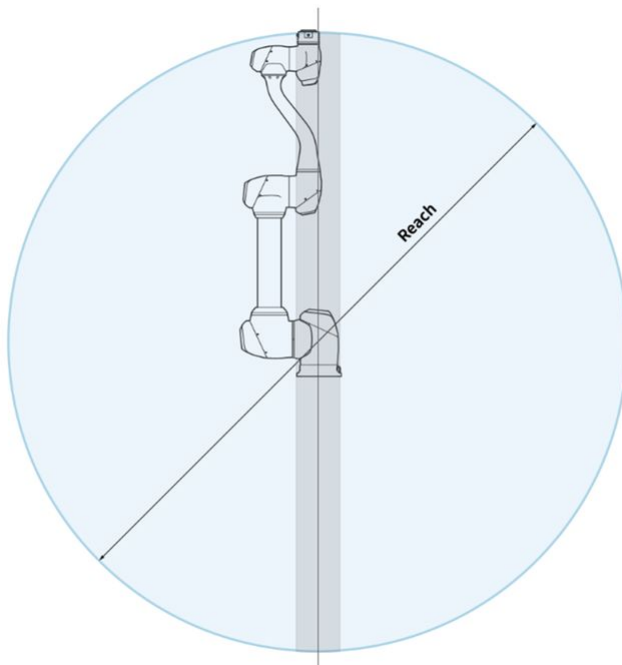

Warning

The grayed areas in the figure are areas where the robot has difficulty performing work. Within this area, the speed of tools is low but the speed of joints is high, so it becomes difficult to perform risk assessment in this area because the robot operates inefficiently. Therefore, it is not recommended to operate the tool passing through the cylindrical section on the top and bottom of the base.

3.2.3 Hardware Installation

Install the robot, controller and teach pendant, the key components of the system in the work area, and supply power to them before operating the robot. The installation of each component is as follows:

Securing the Robot

Use M8 bolts in the four 9.0 mm holes on the manipulator base to secure the robot.

- It is recommended to use tightening torque of 20 Nm to tighten the bolts.
And use a washer(plain or spring) to prevent loosening of the tension caused by vibration.
- Use a $\Phi 5$ place marker pin to accurately install the manipulator in a fixed location.

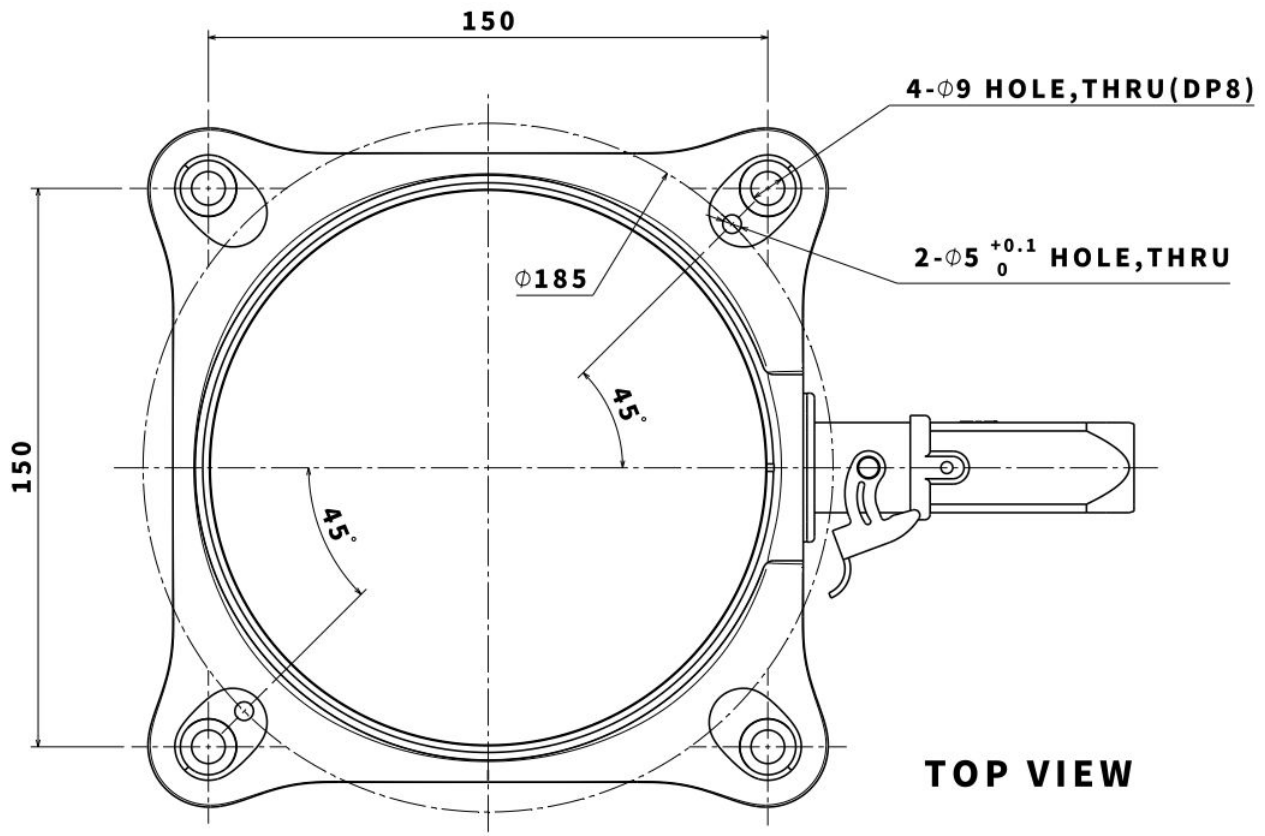

The manipulator base drawing and four M8 bolts are used (M series). Unit [mm]

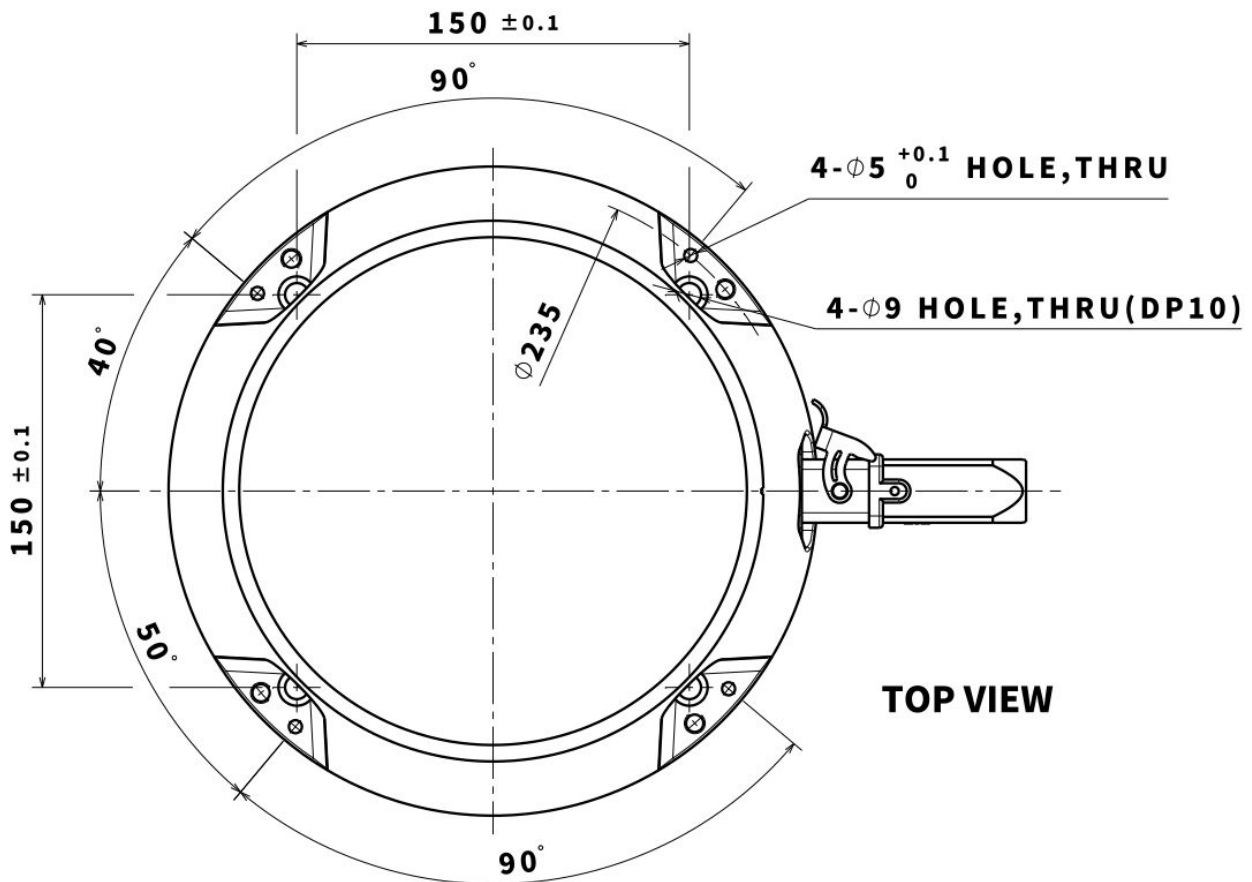

The manipulator base drawing and four M8 bolts are used (H series). Unit [mm]

⚠ Warning

- Tighten the bolts all the way to prevent loosening during manipulator operation.
- Install the manipulator base on a solid surface that can withstand the load generated during operation (10 times the maximum torque and five times the weight of the robot).
- The robot will interpret manipulator base vibration as a collision and engage the emergency stop. Therefore, for installation locations that automatically shift position, do not install the robot base in a location with high movement acceleration.
- Mount the manipulator arm in a specific location using appropriate methods. The mounting surface must be solid.
- The manipulator will be damaged if it comes in contact with water for an extended period of time. Do not operate the robot in conditions where it can get wet or under water.

Connecting the Manipulator and Controller

1

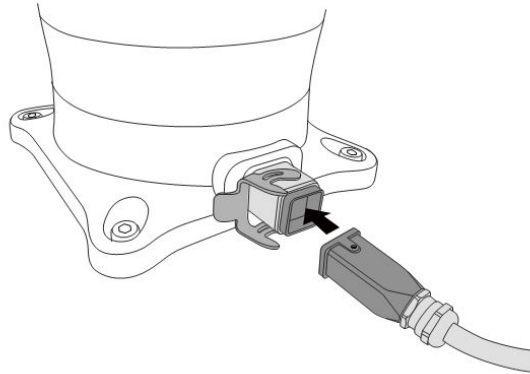

2

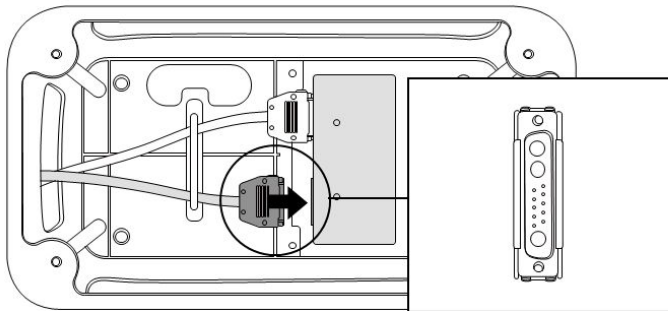

Description

- 1 Connect the Manipulator cable to the controller, place a securing ring
 - Connect the manipulator cable to the corresponding controller connector and place a securing ring on it to prevent the cable from becoming loose.
- 2 Connect the Manipulator cable's opposite end to the controller connector
 - Push the manipulator cable's opposite end into the corresponding controller connector until a click is heard to prevent the cable from becoming loose.

⚠ Caution

- Do not disconnect the manipulator cable while the robot is turned on. This can cause damage to the robot.
- Do not modify or extend the manipulator cable.
- When installing the controller on the floor, secure at least 50 mm of space on each side of the controller to enable ventilation.
- Make sure that connectors are properly connected before turning on the controller.

Note

- When configuring the system, it is recommended that a noise reducer be installed to prevent noise effects and malfunction of the system.
- If the controller is influenced by noise generated by electromagnetic waves, it is recommended to install a ferrite core on each side of manipulator cable to ensure normal operation. The installation location is as follows:

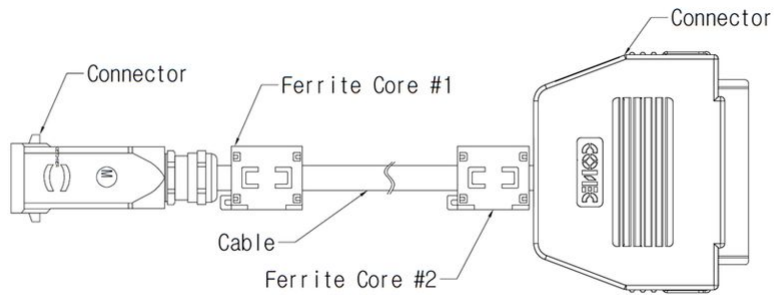

Connecting the Controller and Teach Pendant

Push the teach pendant cable into the corresponding controller connector until a click is heard to prevent the cable from becoming loose.

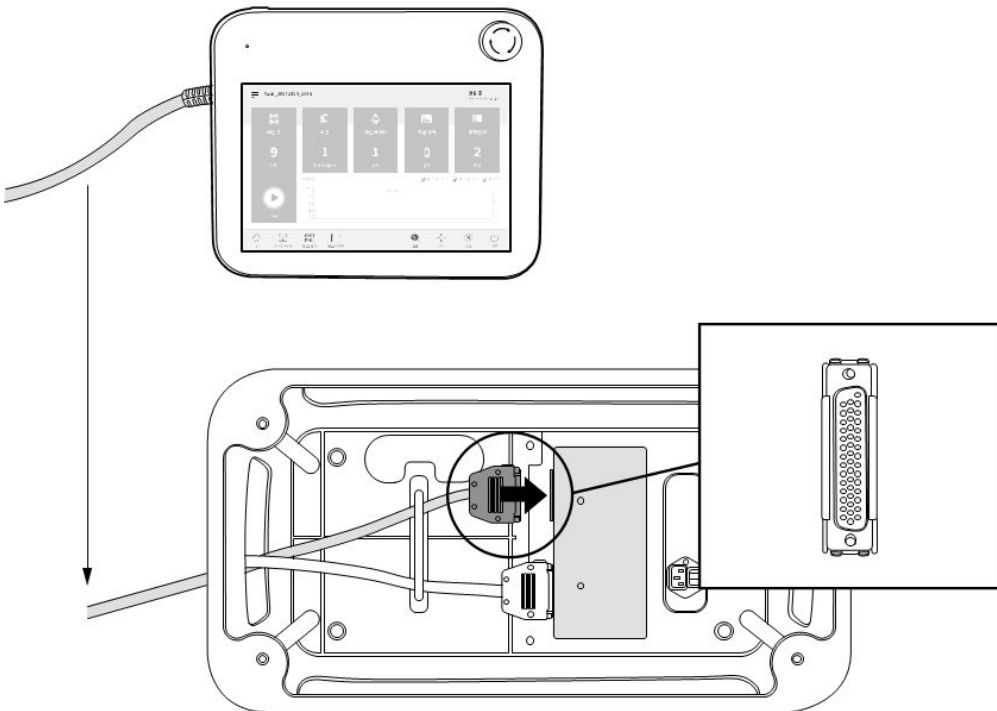

⚠ Caution

- Make sure that the pins of the cable end are not damaged or bent before connecting the cable.
- If the teach pendant is used by hanging on a wall or on the controller, be careful not to trip on the connecting cables.
- Be careful not to allow the controller, teach pendant and cable come in contact with water.
- Do not install the controller and teach pendant a in a dusty or wet environment.
- The controller and teach pendant must not be exposed to a dusty environment that exceeds IP20 ratings. Be especially careful in environments with conductive dust.

ℹ Note

- When configuring the system, it is recommended that a noise reducer be installed to prevent noise effects and malfunction of the system.
- If the teach pendant is influenced by noise generated by electromagnetic waves, it is recommended to install a ferrite core on the Teach Pendant connection side to ensure normal operation. The installation location is as follows:

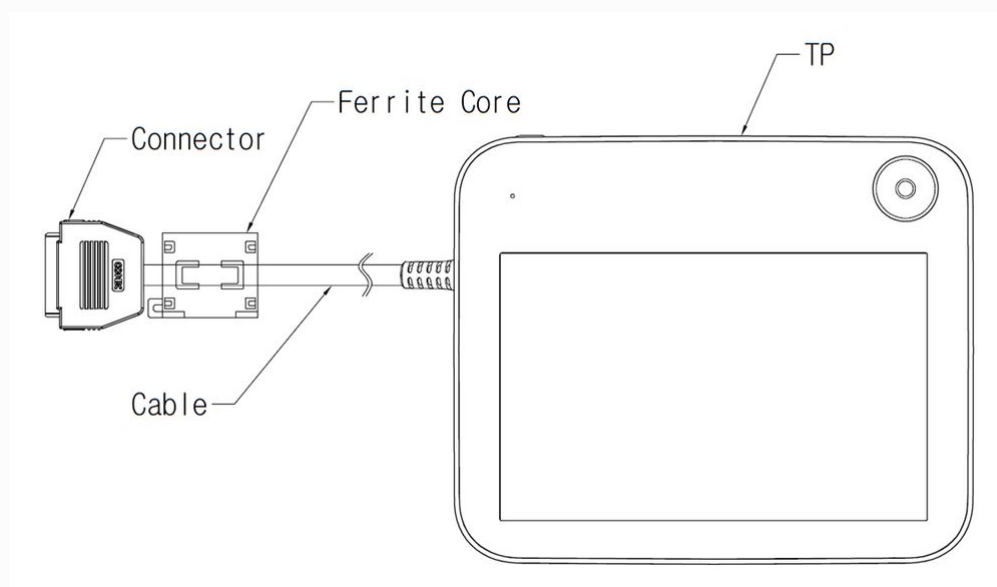

Routing of Manipulator Cable and Teach Pendant Cable

Ensure that the cable curvatures are greater than the minimum curvature radius. The minimum curvature radius of each cable is as follows:

Cable	Minimum curvature radius (R)
Teach pendant cable	120 mm
Robot cable	120 mm

Cable	Minimum curvature radius (R)
Smart pendant cable	100 mm
Emergency stop button cable	100 mm

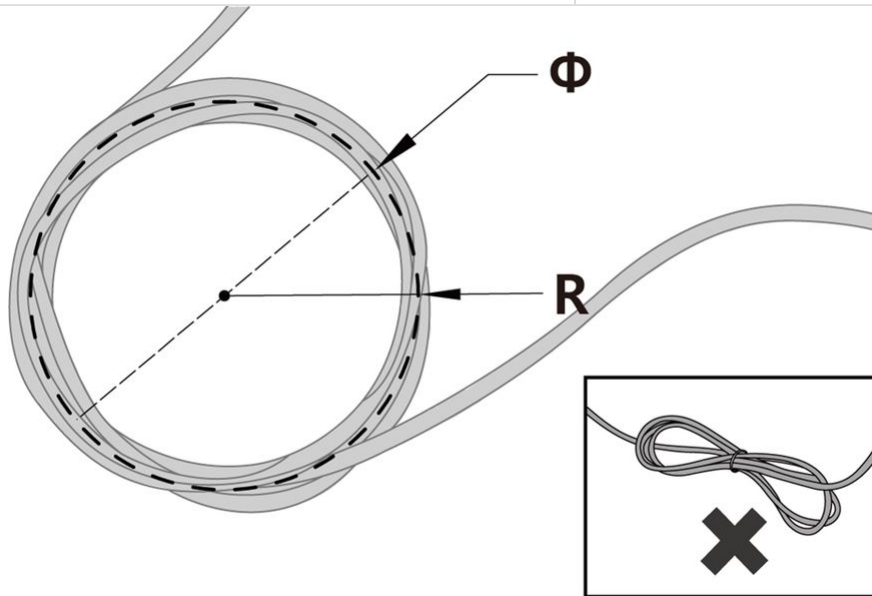

⚠ Caution

- Ensure that the curvature radius between the teach pendant cable and teach pendant connector is greater than the minimum curvature radius.
- If the curvature radius is smaller than the minimum curvature radius, cable disconnection or product damage may occur.
- In environments where electromagnetic noise can occur, proper cable installation must be taken to prevent malfunctions.

Supplying Power to the Controller

To supply power to the controller, connect the power cable of the controller to a standard IEC power outlet.

- Use a cable with a standard power plug that matches the outlet of the country of use.
- Push the plug completely into the corresponding controller connector to prevent the cable from becoming loose. Connect a standard IEC C14 plug and corresponding IEC C13 cord (refer to below) to the controller.

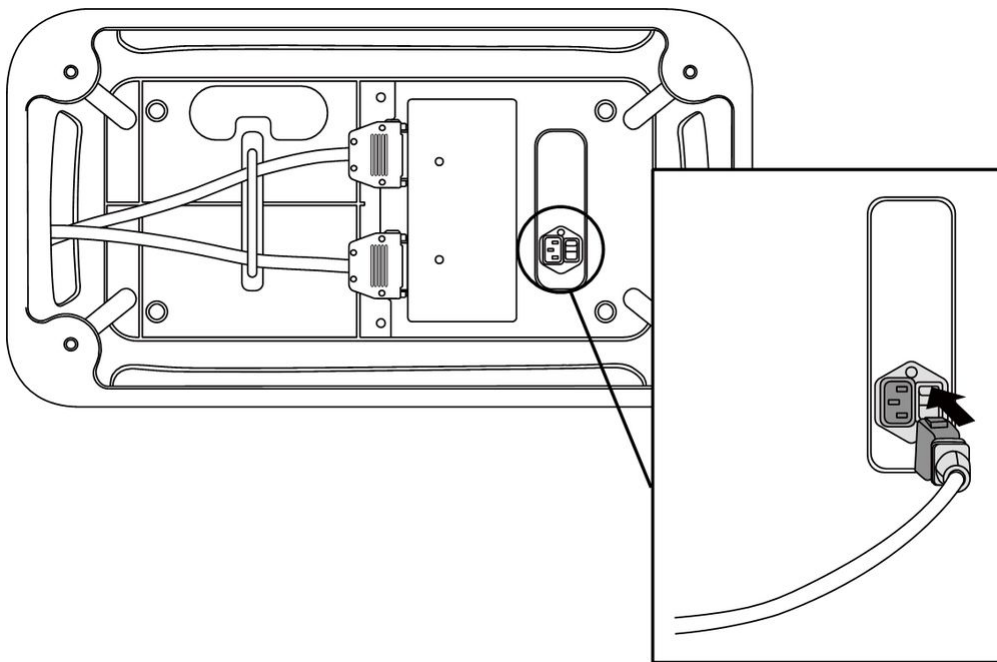

Warning

- After connecting the power cable, make sure that the robot has established a proper ground (electronic ground connection). Establish a common ground for all equipment in the system with an unused bolt related to the ground symbol inside the controller. The ground conductor must satisfy the maximum current rating of the system.
- Protect the input power of the controller using a circuit breaker.
- Do not modify or extend the power cable. It can cause fire or controller breakdown.
- Make sure that all cables are properly connected before supplying power to the controller. Always use the original cable included in the product package.

Note

- When configuring the system, it is recommended to install a power switch that can turn off power to all devices in the system at once.
- The power supply must satisfy minimum requirements such as ground and circuit breakers. The electrical specifications are as follows: (If you selected an optional controller, check the instructions in the appendix)
- If the input voltage is less than 195V, the robot's movement may be limited according to the load and motion.

Parameter	Specification
Input Voltage	100 – 240 VAC

Parameter	Specification
Input Power Fuse (@100-240V)	15 A
Input Frequency	47 - 63 Hz

Connecting the Robot and Tool

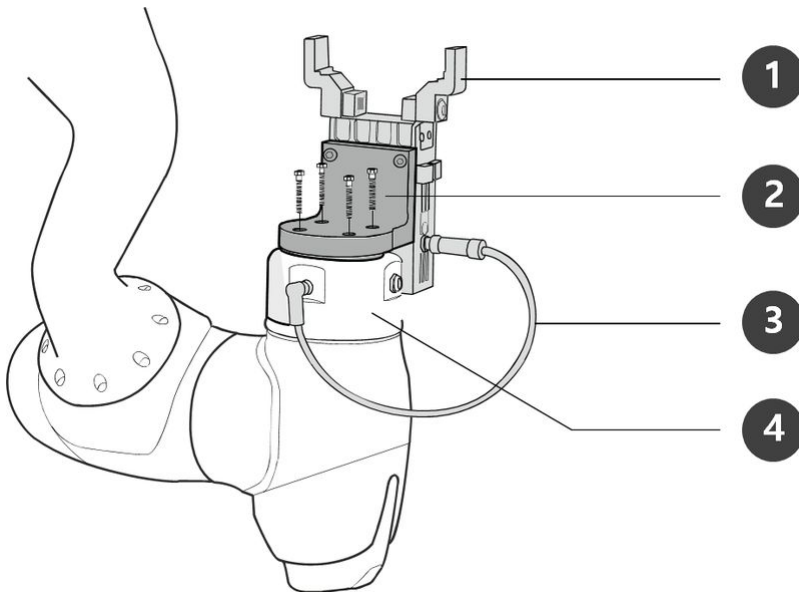

No.	Item
1	Tool
2	Bracket
3	Cable
4	Tool flange

- Use four M6 bolts to secure the tool on the tool flange.
 - It is recommended to use tightening torque of 9 Nm to tighten the bolts.
 - Use a $\Phi 6$ place marker pin to accurately install the robot in a fixed location.
- Connect the necessary cables to the flange I/O connectors after the tool is secured.

**Note**

Methods of securing the tool may vary according to the tool. For more information about tool installation, refer to the manual provided by the tool manufacturer.

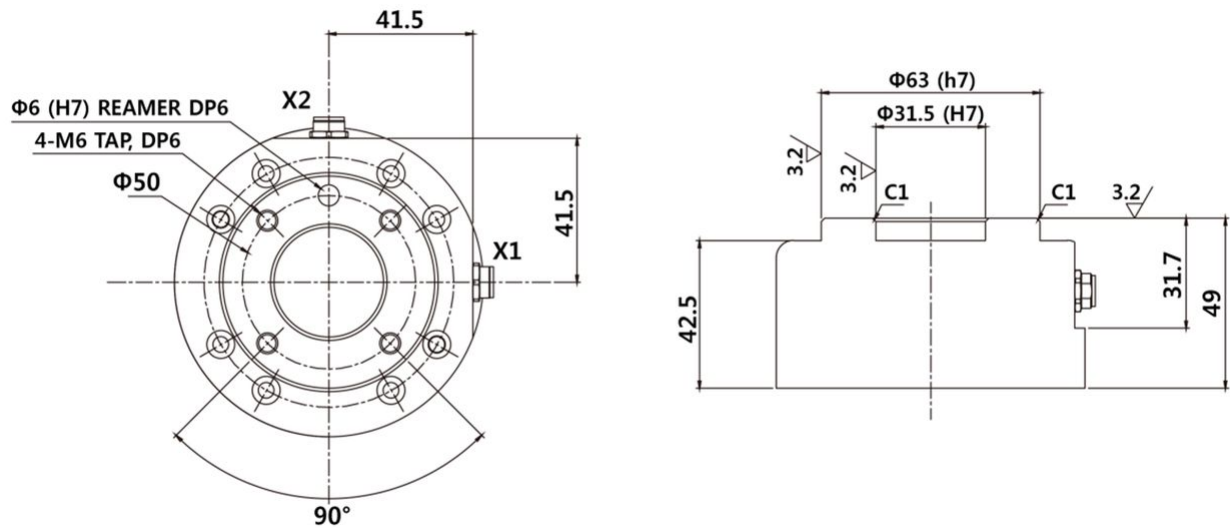
Tool output flange, ISO 9409-1-50-4-M6

3.2.4 Power On/Off Controller Switch

Turn system power on

A power switch is installed on the bottom of the controller to cut off system power. Press the power button on the bottom of the controller.

- The power for systems such as the robot, controller, teach pendant and smart pendant is turned on.

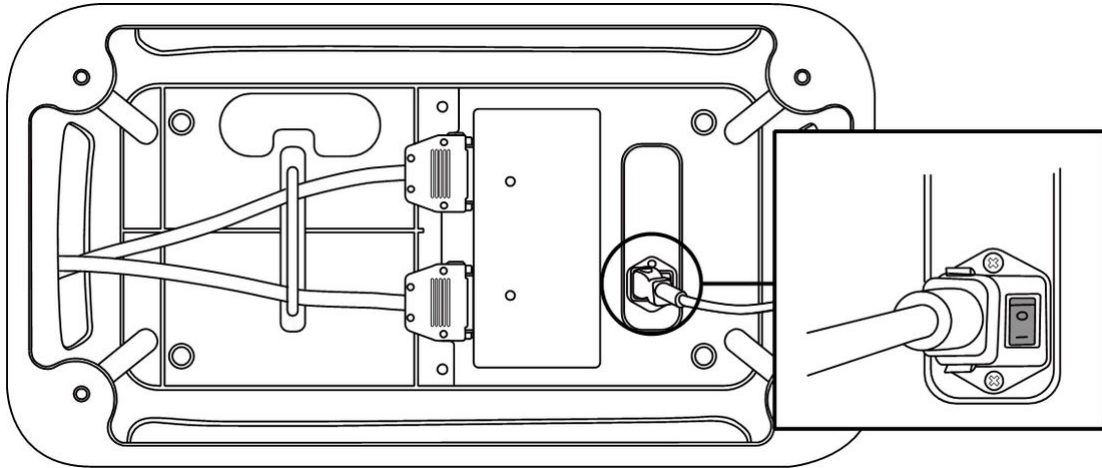

Turn system power off

Before cleaning or servicing the robot or controller, or before disassembling the system, cut off system power using the power switch.

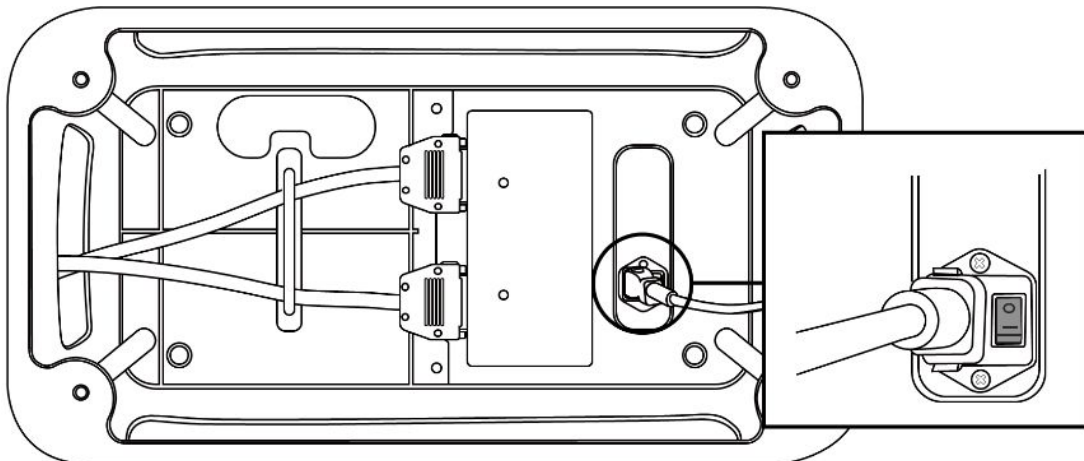

3.3 Interface

3.3.1 Flange I/O

The end flange cover of the robot has two M8 spec 8-pin connectors, and refer to the figure below for the location and shape.

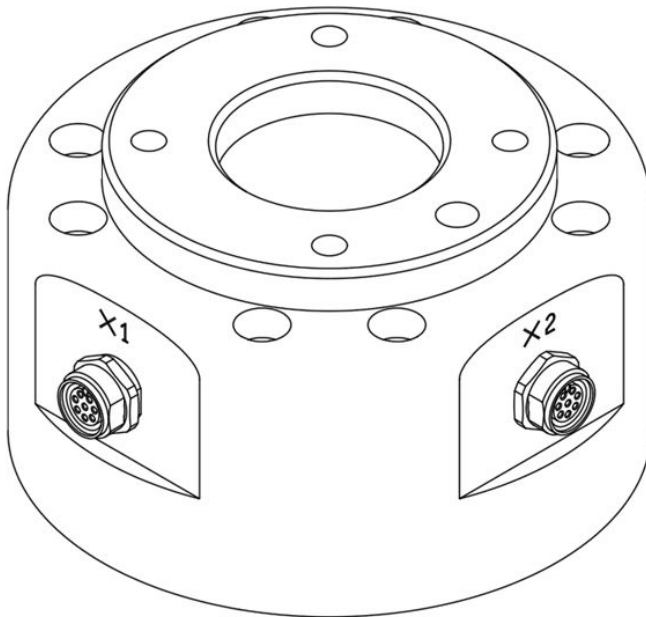

The connector supplies power and control signals necessary to operate the gripper or sensors embedded within specific robot tools. The following are sample industrial cables (equivalent cables can be used)

- Phoenix contact 1404178, male (Straight)
- Phoenix contact 1404182, male (Right Angle)

Schematic Diagram

The pin map of each connector is as follows:

Products manufactured from August 2022, the connector orientation has been changed as shown in the figure below.

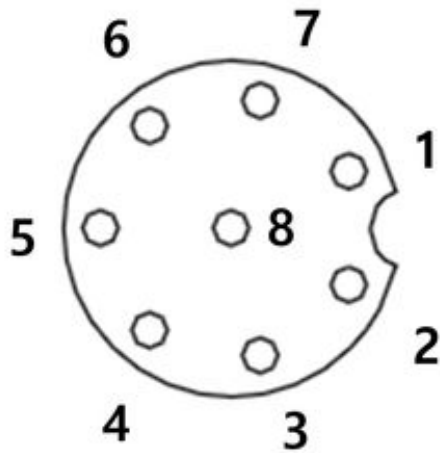

Products manufactured before August 2022 are shown below.

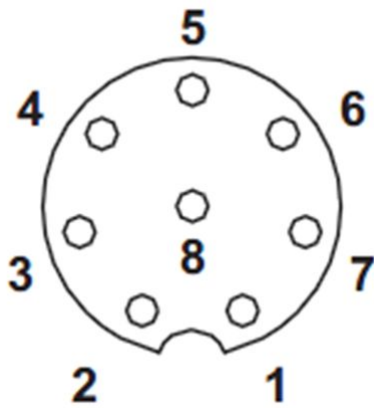

I/O functions provided through X1 and X2 connectors are different from each other, and refer to the table below for detailed I/O settings.

It has been changed as follows since 03.22.2024 onwards.

X1 Setting

No	Signal type	Description
1	Digital Input 1	PNP (Source Type, default)
2	Digital Output 1	set to either PNP (Source Type, default) or NPN (Sink Type)
3	Digital Output 2	set to either PNP (Source Type, default) or NPN (Sink Type)

No	Signal type	Description
4	Analog Input 1 / RS-485 +	set to either Voltage (0-10V) or Current (4-20mA, default) /
5	Power	Set the internal power supply to +24V (default), +12V or 0V
6	Analog Input 2 / RS-485 -	set to either Voltage (0-10V) or Current (4-20mA, default) /
7	Digital Input 2	PNP (Source Type, default)
8	GND	

X2 Setting

No	Signal type	Description
1	Digital Input 3	PNP (Source Type, default)
2	Digital Output 3	set to either PNP (Source Type, default) or NPN (Sink Type)
3	Digital Output 4	set to either PNP (Source Type, default) or NPN (Sink Type)
4	Analog Input 3 / RS-485 +	set to either Voltage (0-10V) or Current (4-20mA, default) / Max 1M baud rate
5	Power	Set the internal power supply to +24V (default), +12V or 0V
6	Analog Input 4 / RS-485 -	set to either Voltage (0-10V) or Current (4-20mA, default) / Max 1M baud rate
7	Digital Input 4	PNP (Source Type, default)
8	GND	

The flange input/output (I/O) initial power is set to 0V and can be set to 12V or 24V.

Refer to the table below for detailed power specifications during I/O connection.

Parameter	Min	Type	Max	Unit
Supply voltage (12V mode)	11.4	12	12.6	V
Supply voltage (24V mode)	22.8	24	25.2	V
Supply current	-	-	3	A

I/O configurations prior to 03.22.2024 are as follows.

X1 Setting (Digital IN/OUTPUT)

No	Signal type	Description
1	Digital Input 1	PNP (Source Type, default)
2	Digital Output 1	set to either PNP (Source Type, default) or NPN (Sink Type)
3	Digital Output 2	set to either PNP (Source Type, default) or NPN (Sink Type)
4	Digital Output 3	set to either PNP (Source Type, default) or NPN (Sink Type)
5	Power	+24V
6	Digital Input 3	PNP (Source Type, default)
7	Digital Input 2	PNP (Source Type, default)
8	GND	

X2 Setting (Digital IN/OUTPUT)

No	Signal type	Description
1	Digital Input 4	PNP (Source Type, default)
2	Digital Output 4	set to either PNP (Source Type, default) or NPN (Sink Type)

No	Signal type	Description
3	Digital Output 5	set to either PNP (Source Type, default) or NPN (Sink Type)
4	Digital Output 6	set to either PNP (Source Type, default) or NPN (Sink Type)
5	Power	+24V
6	Digital Input 6	PNP (Source Type, default)
7	Digital Input 5	PNP (Source Type, default)
8	GND	

Internal power of flange I/O is set to 24V, and refer to the table below for detailed power specifications during I/O connection.

Parameter	Min	Type	Max	Unit
Supply voltage	-	24	-	V
Supply current	-	-	3	A
Digital output	-	6	-	EA
Digital input	-	6	-	EA

Warning

- Set up the tool and gripper so that they do not cause any hazards when power is cut off. (e.g., workpiece falling from the tool)
- The No. 5 terminal of each connector outputs 24V at all times while power is supplied to the robot, so make sure to cut the power supply to the robot when setting up the tool and gripper.

Flange Digital Output Specifications

Flange digital output is a PNP specification, and photo coupler output is set up in the output.

The corresponding output channel becomes +24V when digital output is activated. The corresponding output channel becomes open (floating) when digital output is deactivated.

The electrical specifications of the digital output are as follows:

Parameter	Min	Type	Max	Unit
Voltage when driving 10mA	23	-	-	V
Voltage when driving 50mA	22.8	-	23.7	V
Current when driving	0	-	50	mA

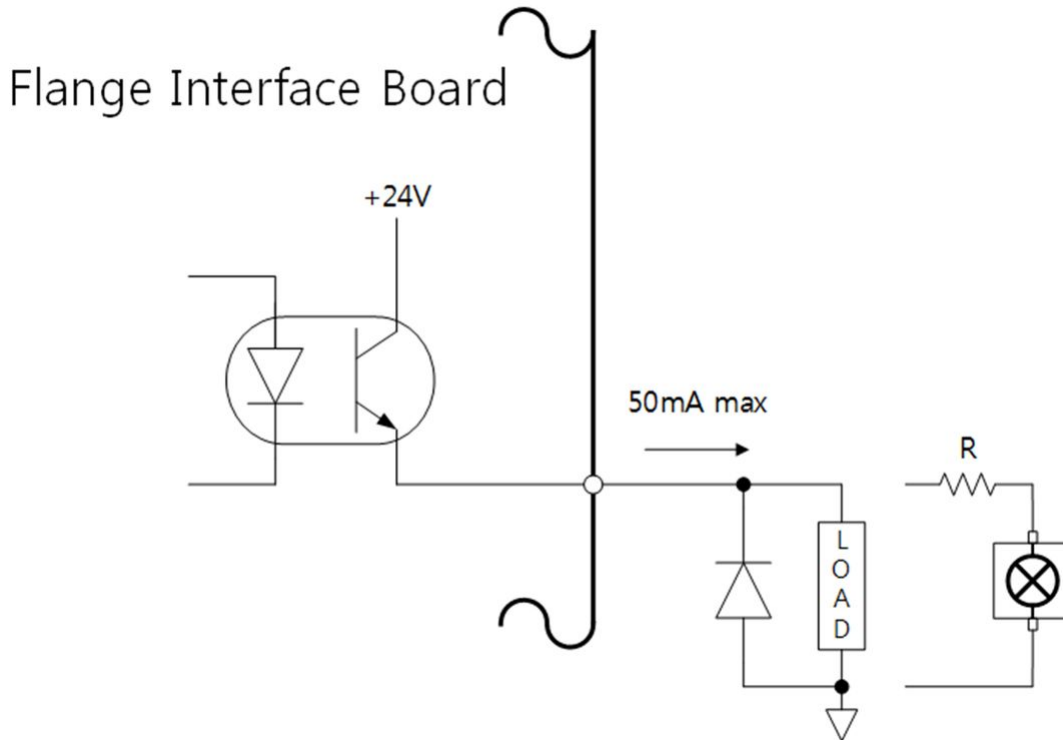

The setting has been changed as follows since April 11, 2024

Digital Outputs support two different modes:

Mode	Active	Inactive
PNP (Source Type, default)	High	Open
NPN (Sink Type)	Low	Open

Digital Outputs initial power is set to 0V, and can be set to 12V or 24V.

When digital output is disabled, the state of the corresponding output channel is open (floating).

The electrical specifications are shown below:

Parameter	Min	Type	Max	Unit
Voltage when driving 12V mode	11.4	12	12.6	V
Voltage when driving 24V mode	22.8	24	25.2	V
Current when driving	0	-	50	mA

⚠ Caution

- Digital output is not subject to current limitation. Ignoring the specifications presented above during operation may cause permanent damage to the product.
- The figure below is an example of a digital output setup, so refer to it while connecting the tool and gripper.
- Make sure to disconnect the power from the robot when setting up the circuit.

Flange Digital Input Specifications

Flange digital input features a photo coupler input.

The current based on 24V input is limited to 5mA by internal resistance.

The electrical specifications of the digital input are as follows:

Parameter	Min	Type	Max	Unit
Input voltage	0	-	26	V
Logical high	4.4	-	-	V
Logical low	0	-	0.7	V
Input resistance	-	4.4k	-	Ω

⚠ Caution

- The figure below is an example of a digital input setup, so refer to it while connecting an input device.
- Make sure to disconnect the power from the robot when setting up the circuit.

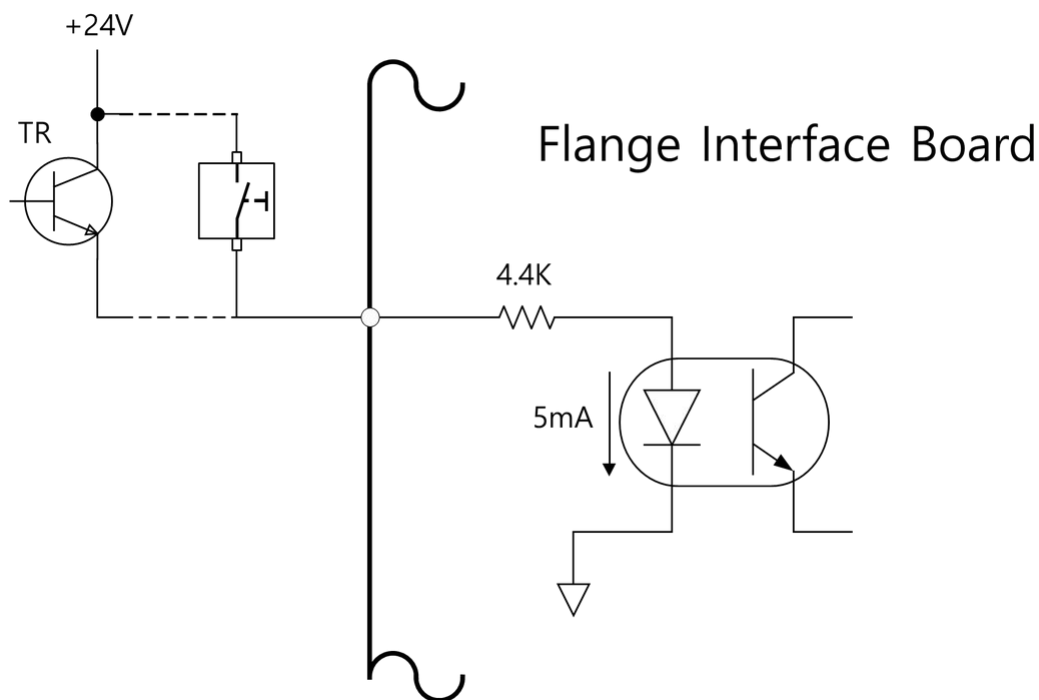

Flange Analog Input Specifications

Receives voltage or current signals from external devices.

Analog Input can be set to voltage (0-10V) or current (4-20mA).

The electrical specifications are shown below.

Parameter	Min	Type	Max	Unit
Input voltage in voltage mode	0	-	10	V
Input current in current mode	4	-	20	mA
Resolution	-	12	-	bit

3.3.2 Connecting Controller I/O

In addition to the manipulator and teach pendant, various external equipment can be connected to the controller through the controller I/O terminal. Various peripherals such as safety devices, including emergency stop switch, light curtain and safety mats, and devices required during robot work cell setup including pneumatic solenoid valves, relays, PLCs and conveyor belt encoders can be connected.

The controller I/O consists of the following six units:

- Terminal Block for Safety Contact Input (TBSFT): Used to connect devices required for emergency stopping and protective stopping
- Terminal Block for Digital I/O Power (TBPWR)
- Configurable Digital IO Block (TBCI1- 4, TBCO1– 4): Used to connect peripherals required for robot operation
- Terminal Block for Analog I/O (TBAIO)
- Terminal Block for Encoder Input (TBEN1, TBEN2)
- Terminal Block for Safety Contact Output (TBSTO): It is connected to the power supply line of the robot peripheral device. When the robot changes to STO state, it is also used for stopping by cutting off the supply power to peripheral devices.

The figure below depicts the electric interface layout of the controller interior.

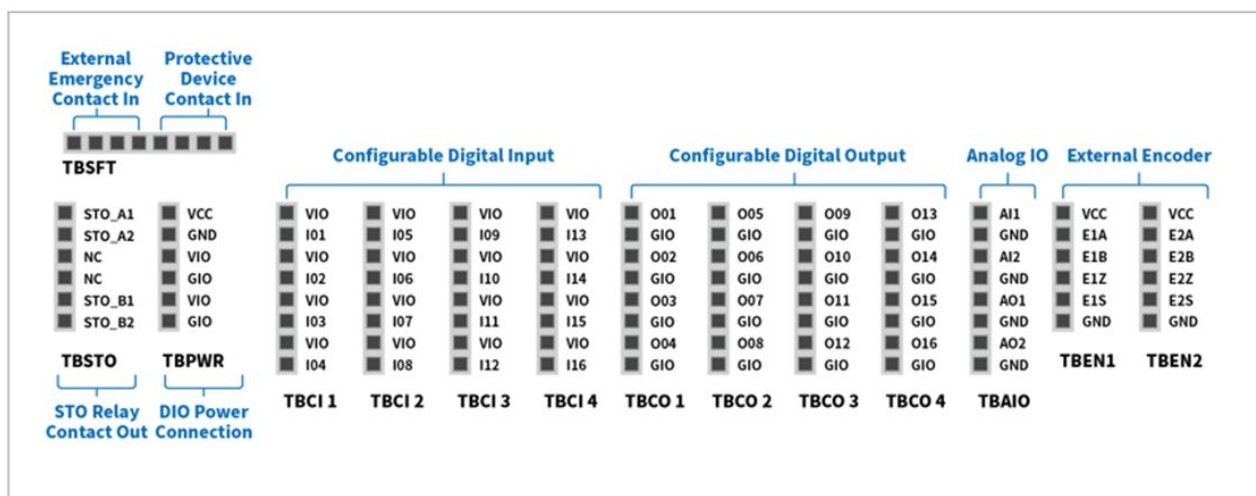

⚠ Caution

- Turn off the power when connecting terminals to the controller I/O to prevent product damage and breakdown.
- Doosan Robotics will not compensate any product damage caused by inappropriate terminal connection or user negligence.
- Make sure to turn off the external power source when turning off the controller power.
- When loosening or tightening the bolt, to prevent any loss, be sure to use magnetic tool.

Setting the Terminal Block for Contact Input (TBSFT)

The safety I/O of the controller consists of dual contact input terminals for connecting safety devices. These terminals are categorized into two groups depending on their use.

- Two pairs of external emergency contact in on the left: Used to connect devices required for emergency stopping such as external emergency switch.

- Two pairs of protective device connect in on the right: Used to connect devices for protective stopping such as light curtain and safety mat.

If no external safety device is connected, connect each contact input as follows:

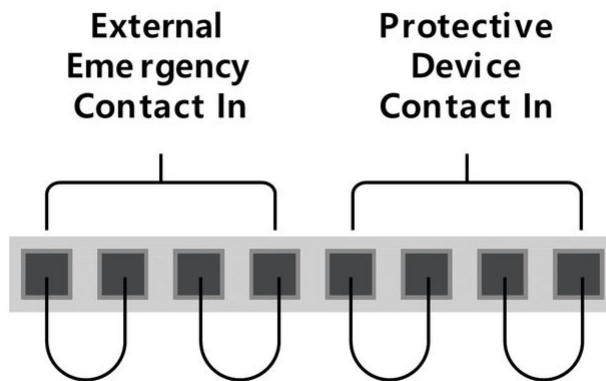

The external safety device signal recognized by the safety controller depending on the normally closed contact status, where all four contact inputs are normally closed, is as follows:

Contact Status	EM1 contact	EM2 contact	PR1 contact	PR2 contact
Close	Normal	Normal	Normal	Normal
Open	Emergency Stop	Emergency Stop	Protective Stop	Protective Stop

Warning

- Do not connect the safety signal to regular PLCs that are not safety PLCs. Failure to do this will result in inappropriate operation of the safety stop function, which can cause severe injury or death to the user.
- If any of the contacts are open, the robot will stop operation according to the safety stop mode setting, and the LED on the right side of the TBSFT lights up. EMGA (Red), EMGB (Red), PRDA (Yellow), PRDB (Yellow)

Note

- EMGA : Emergency Stop channel A(EM1) LED
- EMGB : Emergency Stop channel B(EM2) LED
- PRDA : Protective Stop channel A(PR1) LED
- PRDB : Protective Stop channel B(PR2) LED

⚠ Caution

To check for connection losses and connection shortages, this terminal must be connected to devices that output a safety signal as contacts. To connect peripherals that output safety signals as voltages to the safety controller, refer to the description for [Setting the Configurable Digital I/O \(TBCI1 - 4, TBCO1 - 4\)](#) (p. 204).

Setting the Digital I/O Power Terminal (TBPWR)

VIO and GIO are power terminals used for the safety controller digital I/O located in the front of the controller and are separated from the VCC24V and GND that supply SMPS inside the controller. If the user uses a current of 2A or less for the configurable digital I/O, and if there is no insulation for the connected I/O device and controller, the internal power supply of the controller can be used as the I/O power supply, as shown in the figure below. (factory default setting)

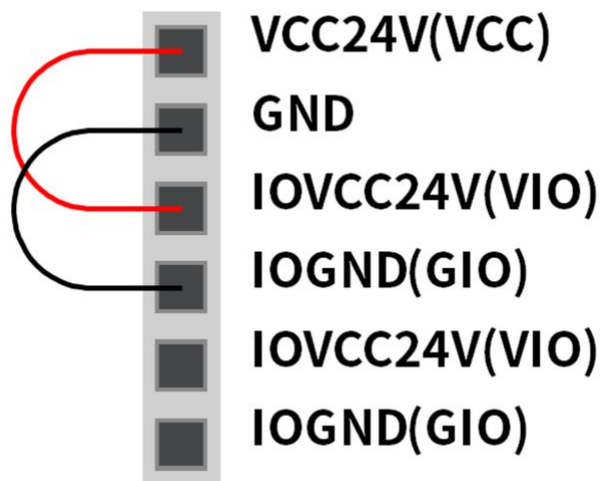

If a current greater than 2 A is required, it will be necessary to connect a separate external power source (24V) using VIO and GIO terminals.

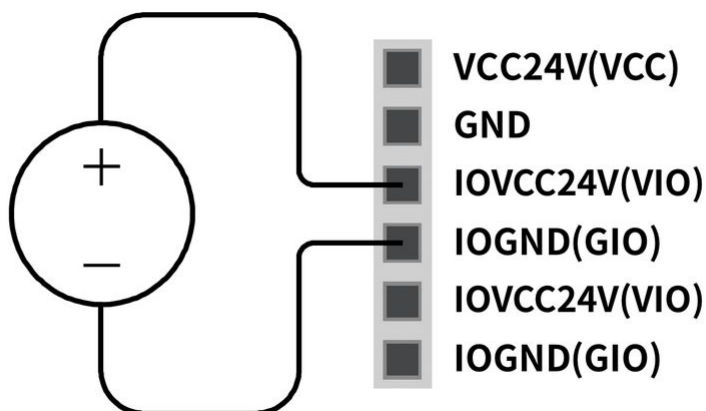

When VIO power is supplied, the IOPW (green) LED on top of the TBPWR lights up.

⚠ Caution

Make sure to turn off the external power source (SMPS) when turning off the power for the controller.

📘 Note

- If a current greater than 2A is connected to the VCC and GND of TBPWR, the fuse in front of the terminal power output shorts to ensure the safety of the controller internal system connected to the same SMPS.
- If a current greater than 2A is required for the configurable digital I/O, make sure to connect an external power source (24V) to VIO and GIO.

Setting the Configurable Digital I/O (TBCI1 - 4, TBCO1 - 4)

The digital I/O of the controller consists of 16 inputs and 16 outputs. They are used to connect peripherals required for robot control or are set as a dual safety I/O to be used as safety signal I/O purposes.

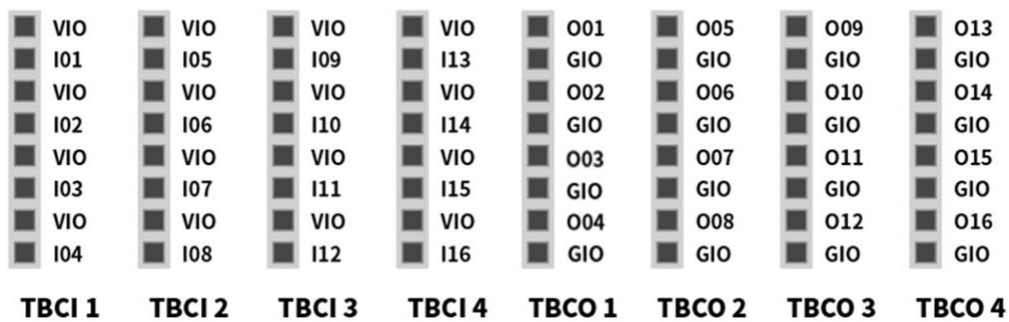

The electrical specifications of the configurable digital I/O are as follows:

Terminal		Parameter	Specification
Digital Output	[Oxx]	Voltage	0 - 24 V
	[Oxx]	Current	0 - 1 A
	[Oxx]	Voltage Drop	0 - 1 V
	[Oxx]	Leakage Current	0 - 0.1 mA
Digital Input	[Ixx]	Voltage	0 - 30 V
	[Ixx]	OFF Range	0 - 5 V
	[Ixx]	ON Range	11 - 30 V

Terminal	Parameter	Specification
[lxx]	Current	2 – 15 mA

⚠ Caution

The VIO (IO 24V) and GIO (IO GND) terminals that can be used as power supplies for digital I/O are separated from the VCC (24V) and GND of other power supplies on the safety I/O circuit. Take caution as the diagnostic functions of the robot will detect errors if the internal power supply is connected as a digital I/O power supply through the Terminal Block for Digital I/O Power (TBPWR), or if 24V power is not supplied to the VIO and GIO terminals through an external power supply, the configurable digital I/O does not work, and shuts off operating power to the robot.

If the configurable digital I/O is used as a general digital I/O, various low current operations such as solenoid valves for voltage and signal exchanges with PLC systems or peripherals can be performed. The following explains how to use the configurable digital I/O:

If dry contact input is received

This is a method of connecting a switch or contact between the VIO terminal of terminal blocks TBCI1-TBCI4 and lxx terminals. The output of the external device only acts on the open/close of the contact through the relay, so it is electrically insulated from external devices.

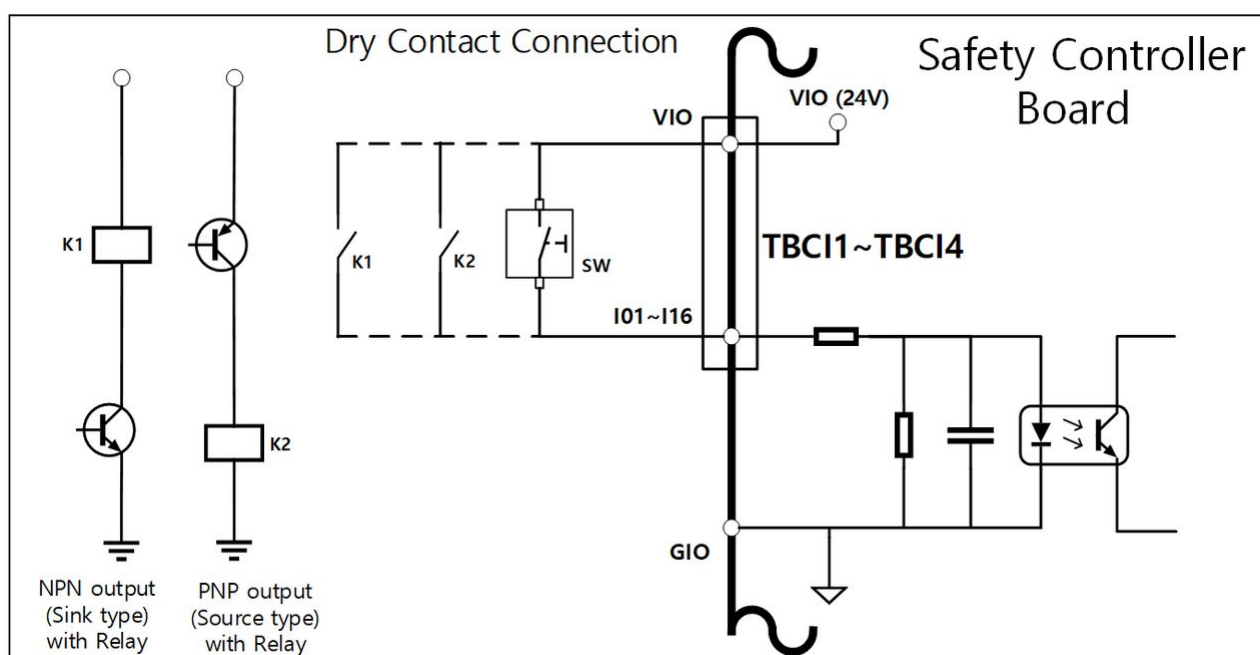

If wet contact input is received

It receives voltage type signals from external devices. If the output of the target device is a source type, it receives a voltage of 24V/0V as input. If the output of the target device is a sink type, a relay can be added to

receive voltage 24V/0V as input. Since voltage input requires a reference, the external devices and the external power supply must be connected to a common ground.

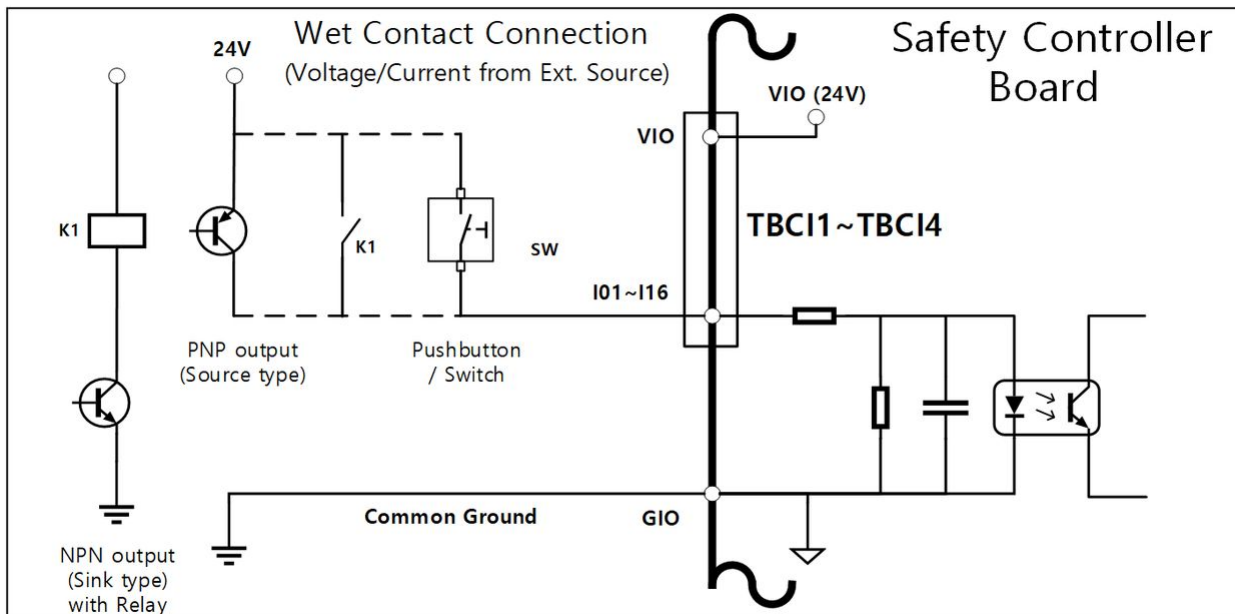

If a simple load is operated

It is a method of connecting loads between the Oxx terminals of TBC01-TBC04 terminal blocks and the GIO terminal.

Each terminal is capable of outputting a maximum of 1A, but the overall current may be limited according to the calorific value and load.

If digital I/O power (VIO/GIO) is supplied through the internal power supply as in the factory default setting, up to 2A of VIO current can be used. If a total current greater than 2A is required, remove the connection between the digital I/O power supply (VIO/GIO) of the Terminal Block for Digital I/O Power (TBPWR) and the internal power supply (VCC/GND), and an external power supply must be connected.

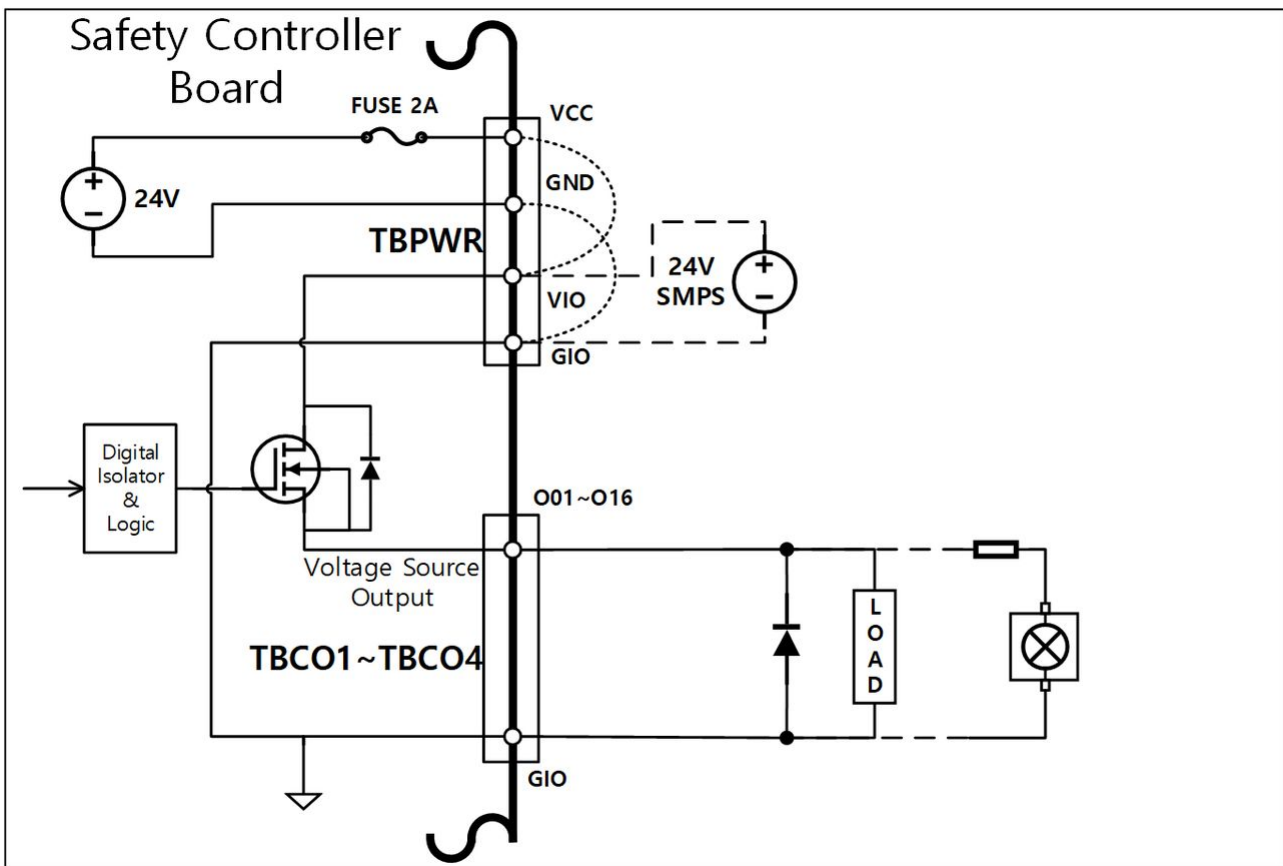

If a negative common & sink type input device is connected

If digital I/O output is connected to a sink type input device, connect the Oxx terminals of the TBCO1-TBCO4 terminal blocks to the input terminal of the external device, and connect the GIO to the negative common of the external device to establish a common ground.

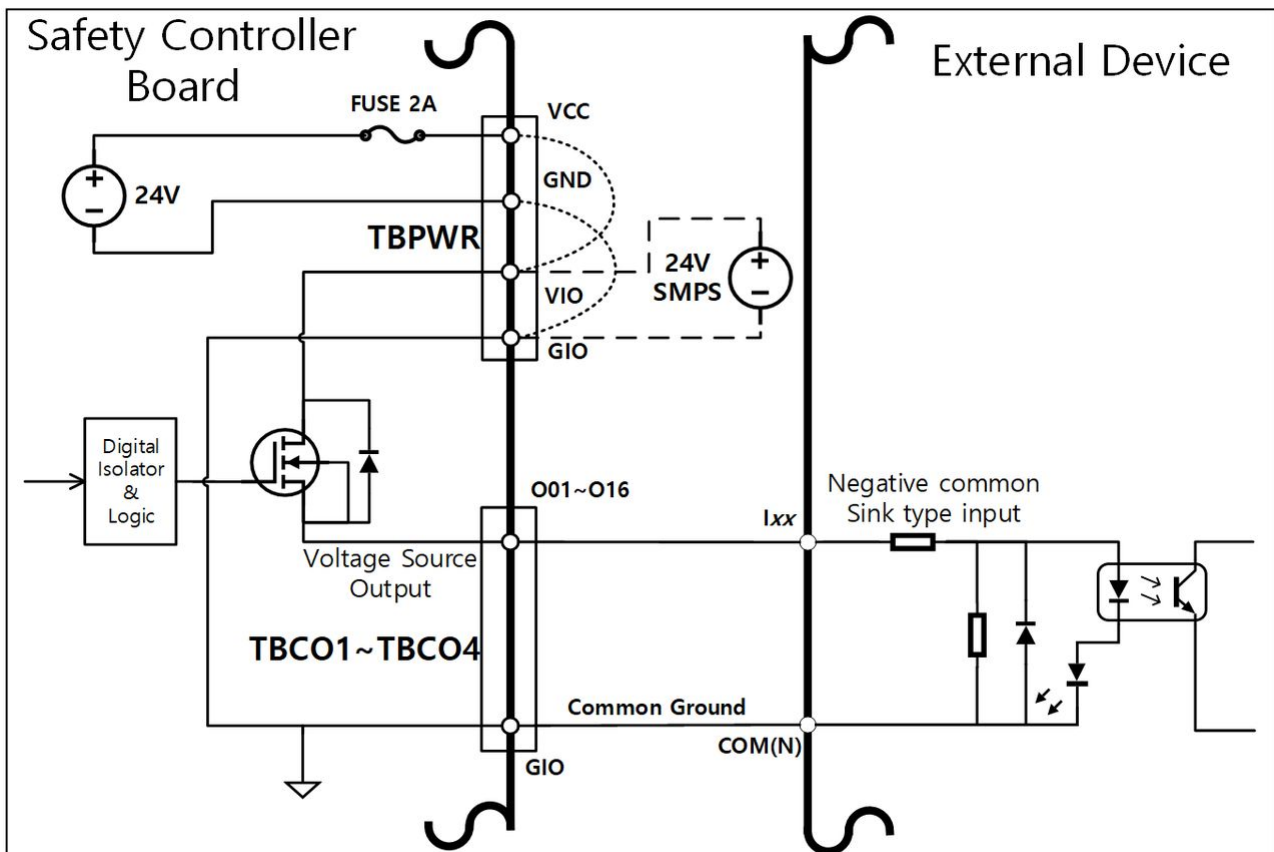

If a positive common & source type input device is connected

Connect a relay between the Oxx terminal of the TBCO1-TBCO4 terminal blocks and GIO terminal to supply input signals as contacts to the external device. If necessary, an external power supply can be connected to the external device.

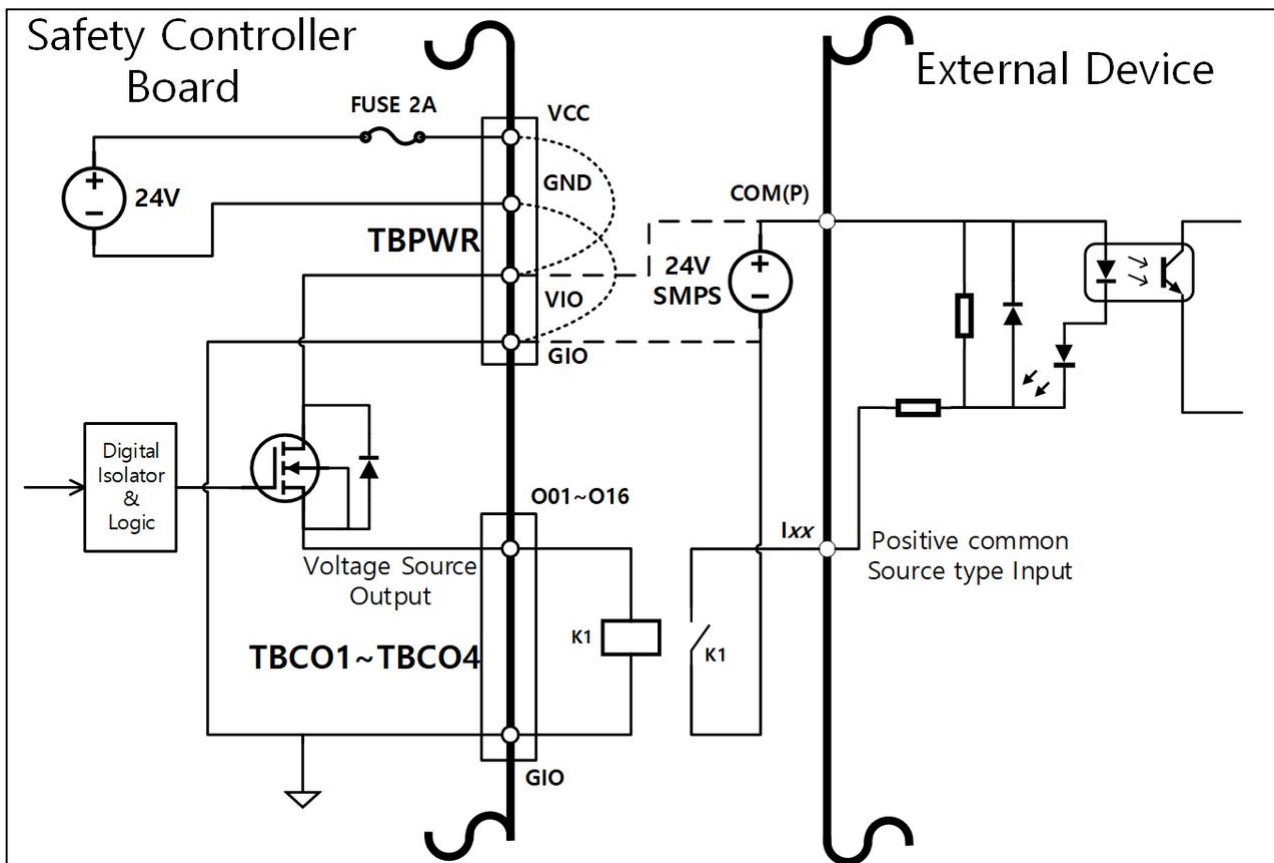

⚠ Caution

- General digital I/O devices can stop at any time due to controller power shortage, self-diagnosis error detection and work program setting. Therefore, perform risk assessment before setting up a robot workcell, and if additional risks such as workpiece falling, ignoring digital input or synchronization error due to incorrect recognition, make sure to implement additional safety measures.
- The general digital I/O is a single connection type I/O and any short circuits or breakdown can result in the loss of safety functions, so it cannot be used for safety purposes. If connection of safety devices or safety related I/O is required, make sure to set the corresponding terminal to dual safety I/O on the teach pendant.

If the configurable digital I/O is used as a safety I/O

Two neighboring I/O terminals, such as O01 & O02, ..., O15 & O16, I01 & I02, ... I15 & I16, can use identical safety signals to form a dual safety I/O.

While the Safety Contact Output Terminal (TBSFT) can only be connected with contact type (Dry Contact) signals, input set as safety I/O can connect with both contact type (Dry Contact) and voltage type (Wet Contact)

signals Output set as safety I/O outputs voltage signals, but it can also output contact type signals by adding an external relay.

The following is an example of connecting a safety device for operation.

- Connect a contact type (Dry Contact) signal emergency switch as a safety input terminal

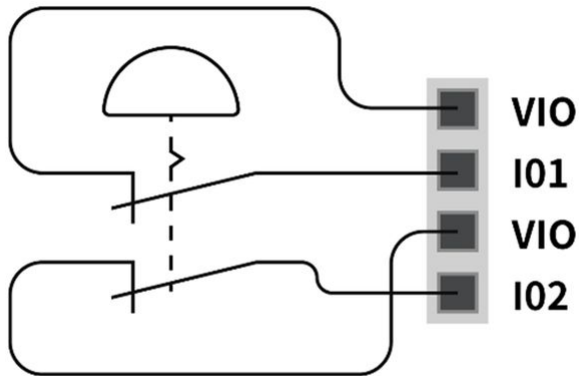

- Connect a voltage type (Wet Contact) signal light curtain as a safety input terminal (common ground)

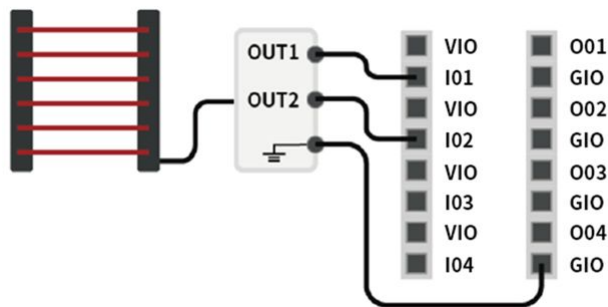

Setting Analog I/O Terminal (TBAIO)

The controller has two analog I/O terminals that can be set to voltage mode or current mode. It can output voltage/current through an external device operated using analog I/O or receive signals from sensors outputting analog voltage/current.

To ensure maximum input accuracy, observe the following:

- Use shielded or twisted pair cables.
- Connect the cable shield to the ground terminal inside the controller.
- Current signals are relatively less sensitive to interference, so use devices operating in current mode for analog I/O terminals. Current/voltage input modes can be set with the software.

The electrical specifications of the analog I/O terminal are as follows:

Terminal		Parameter	Specification
Current mode analog input	[Alx-GND]	Voltage	-
	[Alx-GND]	Current	4 - 20 mA
	[Alx-GND]	Resistance	300 ohm
	[Alx-GND]	Resolution	12 bit
Voltage mode analog input	[Alx-GND]	Voltage	0 - 10 V
	[Alx-GND]	Current	-
	[Alx-GND]	Resistance	1M ohm
	[Alx-GND]	Resolution	12 bit
Current mode analog output	[AOx-GND]	Voltage	-
	[AOx-GND]	Current	4 - 20 mA
	[AOx-GND]	Resistance	50M ohm
	[AOx-GND]	Resolution	16 bit
Voltage mode analog output	[AOx-GND]	Voltage	0 - 10 V
	[AOx-GND]	Current	-
	[AOx-GND]	Resistance	1 ohm
	[AOx-GND]	Resolution	16 bit

Voltage/current input

It receives voltage or current signals from an external device between the Alx terminal of the TBAIO terminal block and the GND terminal. If the output of the device is a voltage signal, it receives a signal of 0-10Vdc. If the output of the device is a current signal, it receives a signal of 4-20mA.

- Depending on the output signal (voltage/current) of the device, it is necessary to set the controller analog input as “Voltage” or “Current” on the teach pendant.

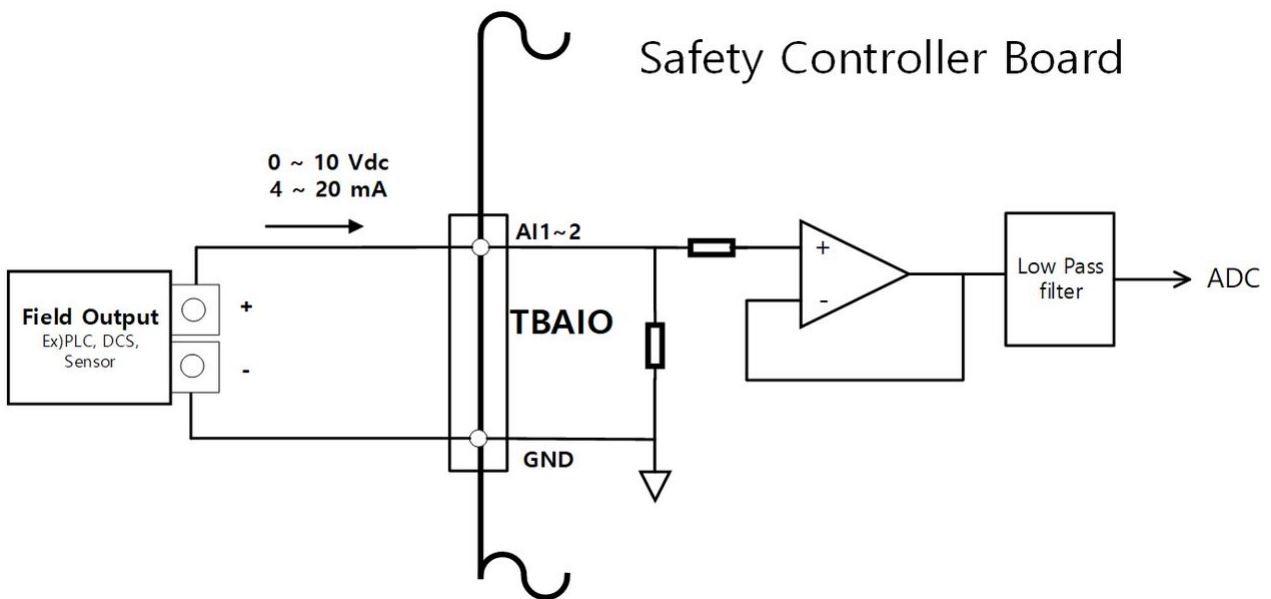

Voltage/current output

It supplies voltage or current signals to an external device between the AOx terminal of TBAIO terminal block and GND terminal. If the input of the device is voltage signal, it supplies a signal of 0-10Vdc. If the input of the device is current signal, it supplies a signal of 4-20mA.

- Depending on the input signal (voltage/current) of the device, it is necessary to set the controller analog output as "Voltage" or "Current" on the teach pendant.

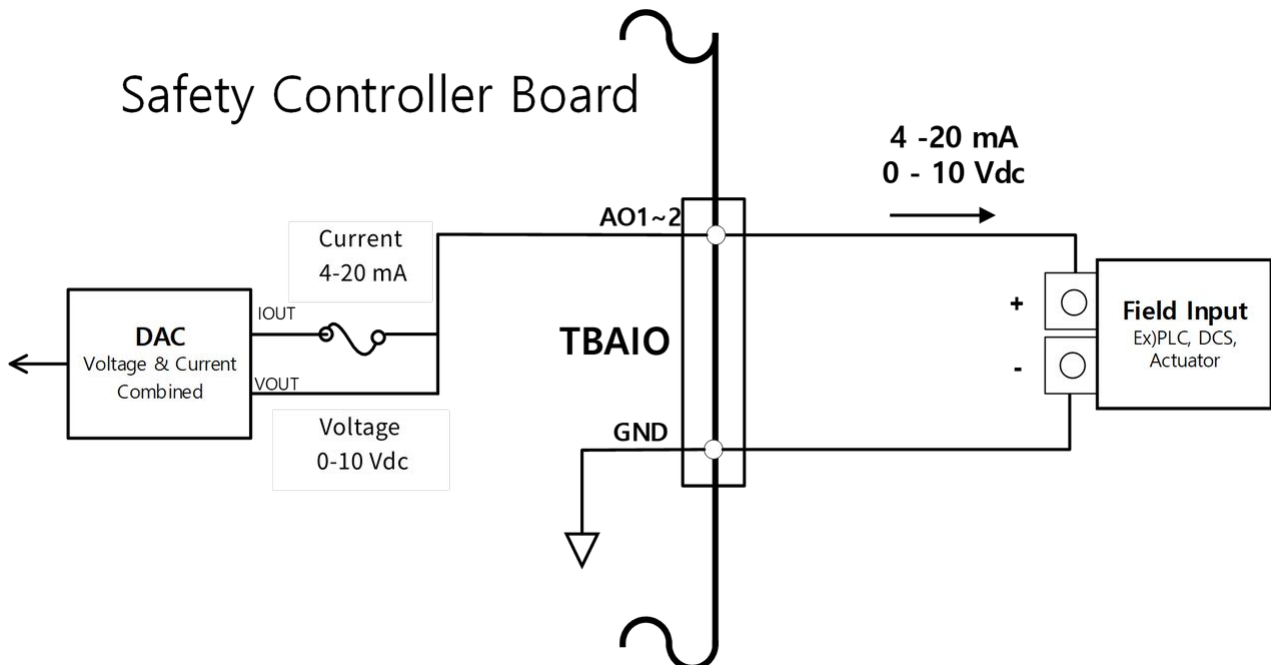

Setting the Terminal Block for Safety Contact Output (TBSTO)

The safety controller supplies a dual relay contact output signal for safety purposes. If the robot is at power cut stop (STO: Safe Torque Off) status, each dual contact opens. If the robot is supplied with operating power (Ready, Run, Jog, etc.), each dual contact closes.

While the output value of the two contacts must be identical, different output values may be generated when open/close takes place. If the output values of the two contacts are longer than the times in the table below, assume connection shortage and hardware defect of the connected external device, and perform inspections. The rated voltage/current of the safety controller relay connected to the contact output terminal is 250VAC/6A.

	Open → Close	Close → Open
Contact output different Max. allowed time	Max. 1 sec.	Max. 0.1 sec.

Setting Encoder Input Terminal (TBEN1, TBEN2)

The controller provides two TBEN terminals that allow the input of external encoders. They support A, B and Z phases as inputs, and perform counts based on 12Vdc. In addition, S phase can be used as the conveyor's Start sensor.

- To ensure maximum input accuracy, observe the following: Use shielded, twisted pair cables to reduce noise.
- Connect the cable shield to the ground terminal inside the controller.
- In the case of S phase inputs, connect a pull-up or pull-down resistance according to the sensor type(NPN/ PNP) to prevent floating.

The figure below shows a sample encoder and sensor configuration, so refer to it while establishing connections.

Connecting Incremental Encoder A, B, Z phase

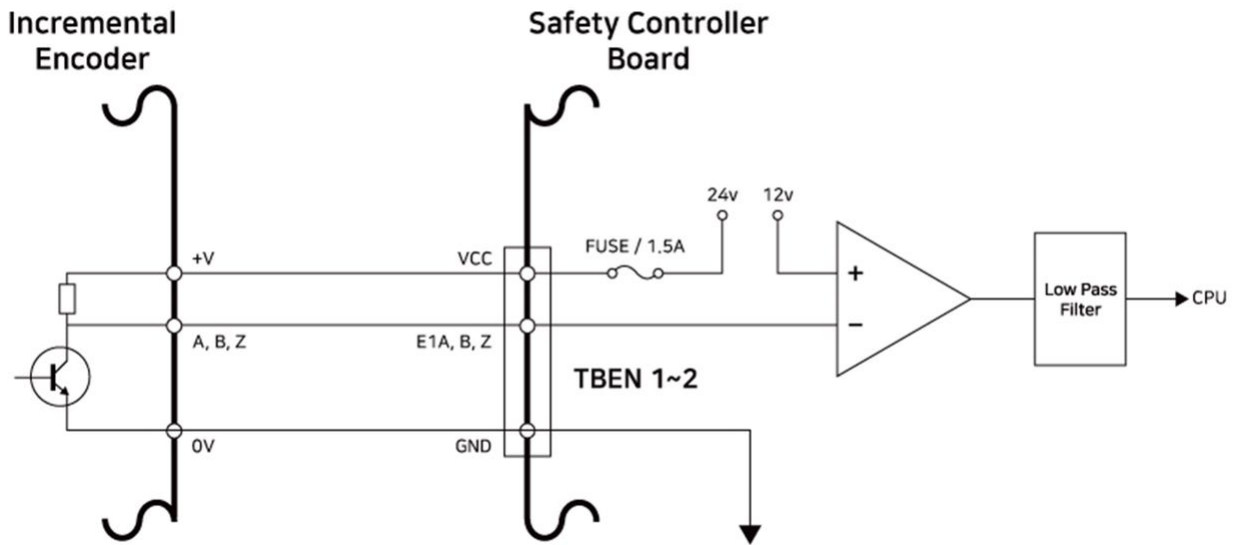

Connecting NPN Sensor

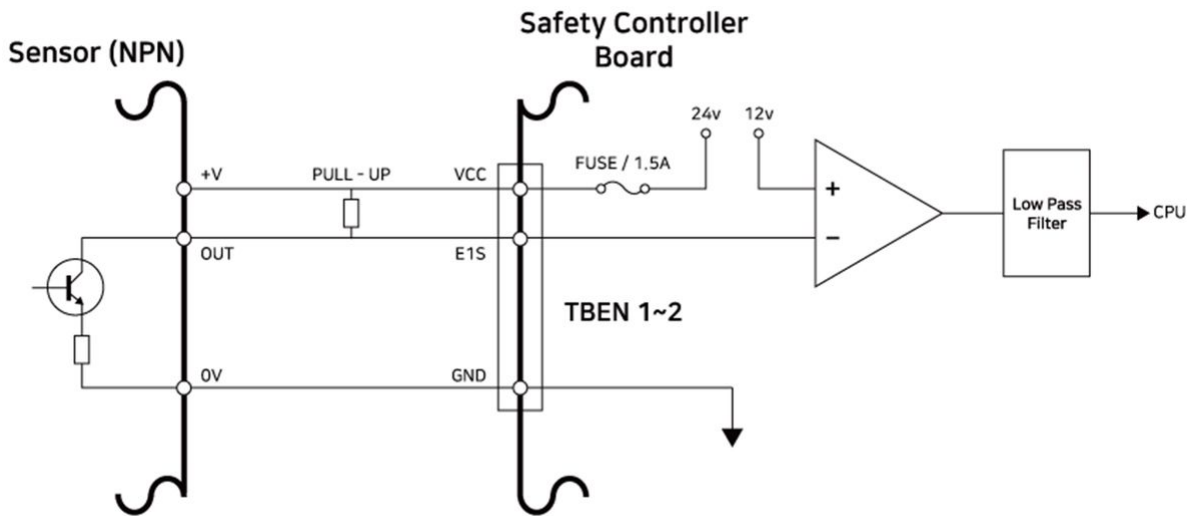

Connecting PNP Sensor

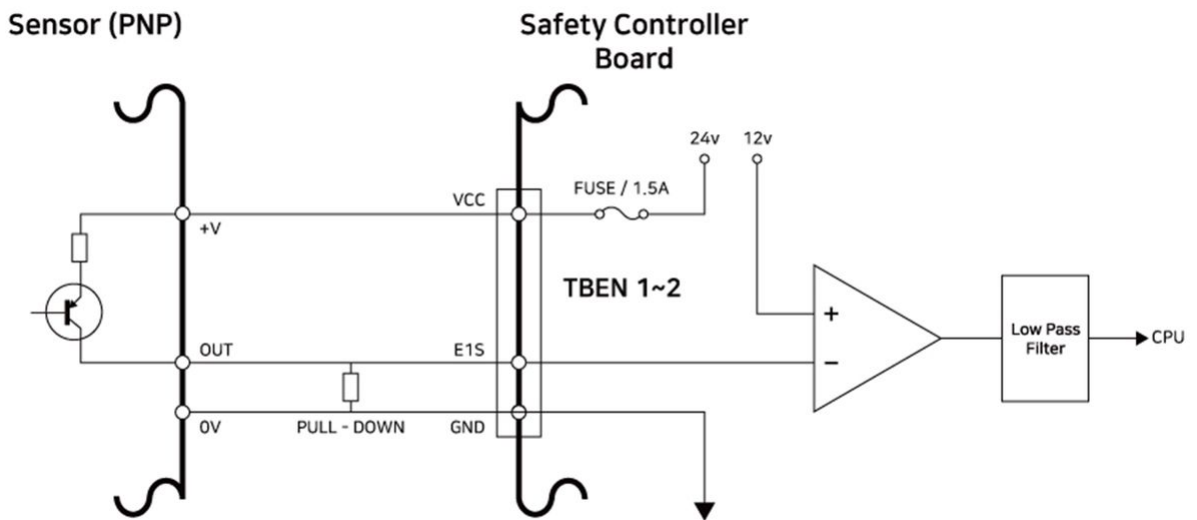

3.3.3 Network Connection

External Internet, TCP/IP equipment and Modbus equipment can be connected to the network router inside the controller.

Connect cables to dedicated ports according to the network application.

- WAN: Connecting external Internet
- LAN: Connecting peripherals using TCP/IP or Modbus protocol

Connecting the cable to the network connection terminal will connect the network (refer to the figure below).

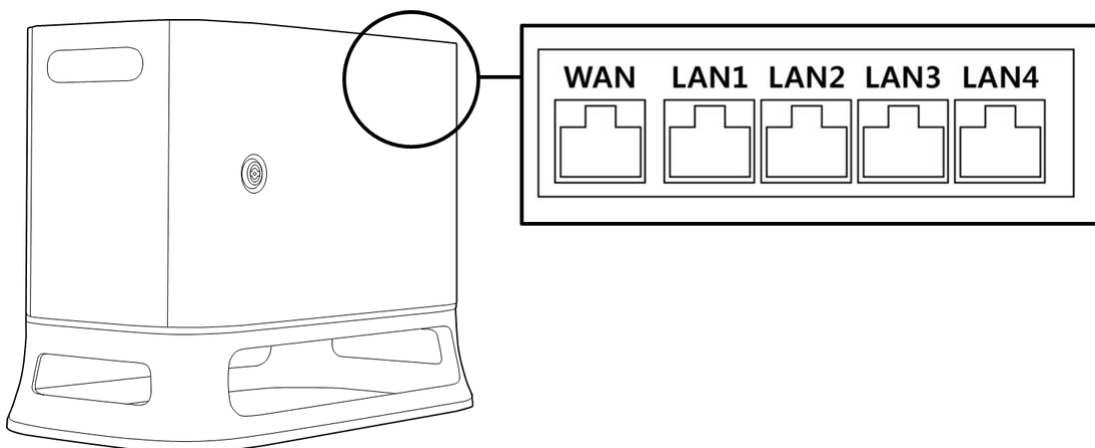

⚠ Caution

The LAN4 port is used to connect internal controllers, so do not connect other equipment.

Connecting External Devices - Vision Sensor

The robot can be connected with a vision sensor (2D camera for object position measurement), and vision sensor measurements can be transferred to the robot through a network to link with commands of the robot.

Vision Sensor Setting

Communication Connection Setting

Connect the LAN ports of the devices and apply TCP/IP communication to transfer vision sensor measurements to the robot. (refer to LAN port connection “**4.3 Network Connection**”) Set the IP address of the vision sensor to TCP/IP 192.168.137.xxx band to allow TCP/IP communication.

Vision Work Setting

To perform object position measurement, it is necessary to have an image input and vision teaching of the target object using the vision sensor. Refer to the dedicated vision work setting program provided by the vision sensor manufacturer.

Measurement Data Format Setting

To use vision sensor measurement data in robot work, it is necessary to perform vision- robot coordinates calibration, and this must be performed before initiating work using the vision sensor setting program. The vision sensor measurement data must be transferred using the following format settings:

Format	pos	,	x	,	y	,	angle	,	var1	,	var2	,	...
--------	-----	---	---	---	---	---	-------	---	------	---	------	---	-----

- pos: Separator indicating the start of measurement data (prefix)
- x: X coordinate value of the object measured using vision sensor
- y: Y coordinate value of the object measured using vision sensor
- angle: Rotation angle value of the object measured using vision sensor
- var1...varN: Information measured using vision sensor (e.g., object dimension / defect check value)

Example) pos,254.5,-38.1,45.3,1,50.1 (description: x=254.5, y=-38.1, angle=145.3, var1=1, var2=50.1)

Robot Program Setting

When the physical communication connection between the vision sensor and robot and vision sensor setting are completed, a program must be set to allow the vision sensor and robot program to be linked. It is possible to connect/communication/control functions of the external vision sensor using Doosan Robot Language (DRL), and it is possible to set up the program in the Task Writer.

Details and comprehensive examples of Doosan Robot Language (DRL) on external vision sensor functions are provided in the [Programming](#)⁴.

4. <https://doosanrobotics-manual.atlassian.net/wiki/spaces/202d147cfaac44138a9be44e5e5895eb/pages/331743366>

Connecting External Device – DART Platform

The DART Platform is software that runs on a Windows OS base desktop or laptop. Once you execute the DART Platform after connecting the Controller and desktop/laptop through the LAN Port, all functions of the teach pendant can be used. To establish a connection with sub-controllers within the controller, the following setup procedure is required.

IP Address Search and Connection Setting

Communication Connection Setting

When a laptop is connected to the LAN port of the controller and the DART Platform is executed, the controller IP address, sub-controller version information and robot serial number required for establishing a connection are automatically searched.

Selecting the serial number of the robot to connect will connect the DART Platform and a sub-controller, allowing the robot to be operated normally.

If there is an issue with the connection, implement the process below. If the issue is not resolved, contact the sales or service staff for assistance.

- If the connectible controller IP address, sub-controller version information and robot serial number search results are not displayed: Press the refresh button to search again and try to connect again according to the procedure above.

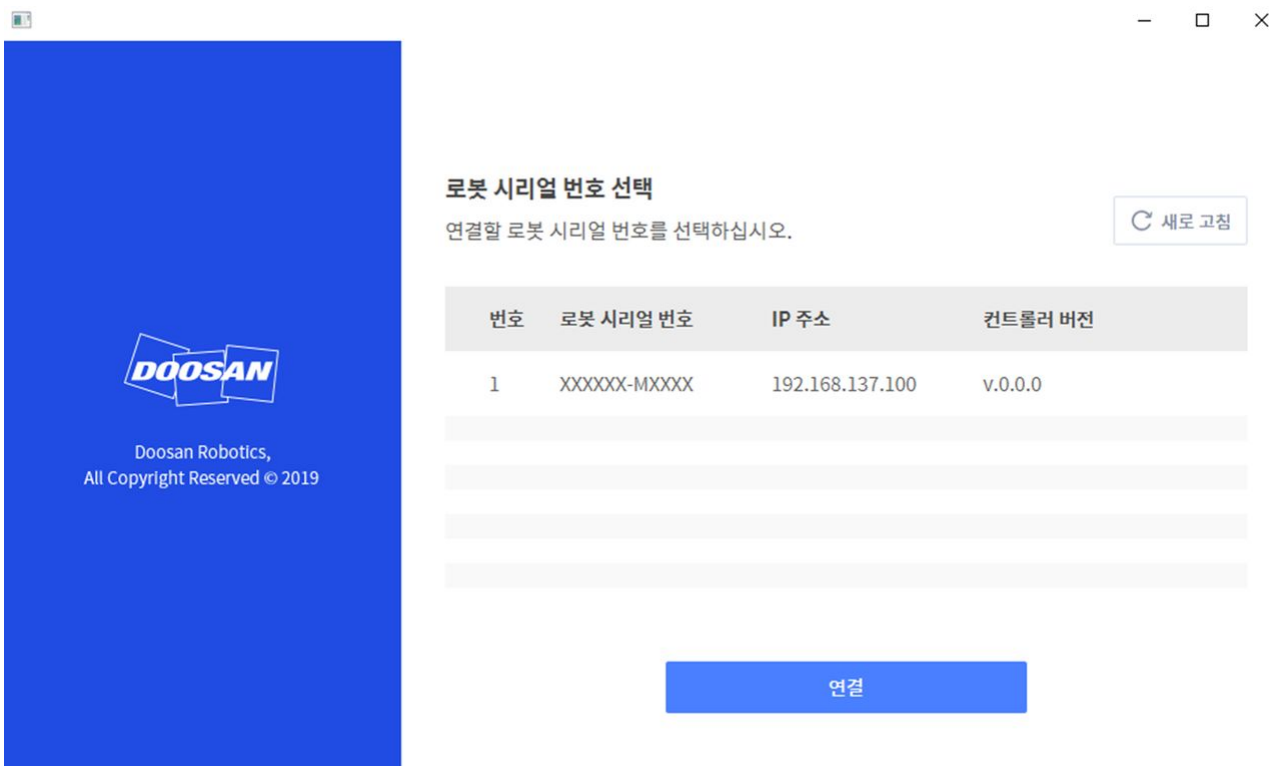

ModbusTCP Slave Setup

The ModbusTCP Slave function of Doosan Robotics supports robot parameter monitoring, and General Purpose Register (GPR) (refer to [Using General Purpose Register\(GPR\)\(p. 219\)](#)) function.

This function automatically starts when the robot controller boots up normally. Therefore, the user can use it after matching the Master IP of the robot controller with the same bandwidth.

Note

- The related I/O Table is provided as a separate file.
- Please refer to the Programming Manual for DRL to use the GPR function.

Expanded Protocol - PROFINET IO Device(pnio device) Setup

The robot controllers of Doosan Robotics support the PROFITNET IO Device (Slave) function, which allows data modification after reading the Parameters of the robot from an external device (PROFINET IO Controller/Master). (i.e., robot parameter monitoring, General Purpose Register (Bit, Int, Float) – refer to [Using General Purpose Register\(GPR\)\(p. 219\)](#)).

For more information about PROFINET, refer to www.profibus.com⁵.

Expanded Protocol - EtherNet/IP Adapter(EIP adapter) Setup

The robot controllers of Doosan Robotics support the EtherNet/IP Adapter (Slave) function, which allows data modification after reading the Parameters of the robot from an external device (EtherNet/IP Scanner / Master). (i.e., robot parameter monitoring, General Purpose Register (Bit, Int, Float) – refer to [Using General Purpose Register\(GPR\)\(p. 219\)](#))

For more information about EtherNet/IP, refer to www.odva.org⁶.

Using Expanded Protocol

The PROFINET IO Device (PNIO device) and EtherNet/IP Adapter (EIP adapter) functions start together at controller startup, and are in connection standby state with the Master device.

Therefore, in order to use the function, it is necessary to connect and set up the Master. Each Master device has different characteristics, so it is necessary to check them.

Note

The following are descriptions of the implementation characteristics of general functions for Industrial Ethernet.

- The Industrial Ethernet function of Doosan Robotics controllers does not use a separate ASIC, but implements its function based on TCP/IP, so it does not support real-time performance.

5. <http://www.profibus.com/>

6. <http://www.odva.org/>

- Data output to external devices has identical markings (PNIO, EIP), but data input to the robot only has identical structures and does not link. Therefore, data output from the PNIO controller does not synchronize with output data from the EIP scanner.
- For the I/O table of PNIO and EIP, please refer to a separate document (or attachment).

Using General Purpose Register(GPR)

The GPR function is the memory of the PNIO device and the EIP adapter predefined by the user for use. It allows exchange of user data between external devices and the robot.

Note

The GPR function is only provided through DRL, and the DRLs used are as follows:

For more information about DRL, please refer to the Programming Manual.

- set_output_register_bit(address, val)
- set_output_register_int(address, val)
- set_output_register_float(address, val)
- get_output_register_bit(address)
- get_output_register_int(address)
- get_output_register_float(address)
- get_input_register_bit(address)
- get_input_register_int(address)
- get_input_register_float(address)

3.4 Transportation

3.4.1 Caution during Transportation

Caution

- If the robot is wrapped in packaging materials and transported, store the robot in a dry location. If the robot is stored in a location with high humidity, condensation may occur inside the packaging material, resulting in robot defects.
- When relocating the robot, consider the weight of the robot's link or base and carry the robot with sufficient personnel at the same time. Especially for H-series, refer to the "Handling Guide" and make sure to carry it in accordance with the safety regulations of the country.
- The controller is moved by grasping the bottom handle.
- When transporting the robot or controller, make sure to maintain the proper posture. Failure to do so may result in back injury or other physical injuries.
- When transporting the robot using lifting equipment, make sure to observe all related national and regional regulations.
- Doosan Robotics does not assume responsibility for any damages or losses that occur during transportation, so make sure to transport the robot safely according to the user manual.

- It is attributable to the user if the robot is damaged by delivering the robot in a position other than the pack position for each model designated by Doosan Rototics

3.4.2 Package Specifications

The box specifications for transport are as follows:

Model	Length	Width	Height	Note
M0609	742 mm	500 mm	400 mm	
	755 mm	452 mm	545 mm	Since December '22
M0617	1206 mm	452 mm	545 mm	
M1013	968 mm	500 mm	435 mm	
	986 mm	452 mm	545 mm	Since October '22
M1509	742 mm	500 mm	400 mm	
	755 mm	452 mm	545 mm	Since December '22
H2017	1040 mm	1040 mm	1585 mm	
	1426 mm	736 mm	626 mm	Since July '22
H2515	1040 mm	1040 mm	1500 mm	
	1426 mm	736	626 mm	Since July '22

3.4.3 Pose for Robot Transportation

Set the following poses to transport the robot:

Model	J1	J2	J3	J4	J5	J6
M0607	0°	0°	150°	0°	25°	0°
M0617	0°	0°	165°	0°	15°	0°
M1013	0°	0°	160°	0°	20°	0°
M1509	0°	0°	150°	0°	25°	0°
H2017	0°	0°	160°	0°	15°	0°
H2515	0°	0°	160°	0°	15°	0°

3.5 Maintenance

System maintenance must be performed by Doosan Robotics or a company designated by Doosan Robotics. Maintenance is intended to keep the system operable or to return the system to an operable state in the event of a problem, and it includes repair work as well as system diagnosis of potential issues.

When maintenance work is completed, risk assessment must be performed to confirm whether the system satisfies required safety levels. Corresponding national and regional regulations must be observed during inspection, and all possibilities related to safety must be tested.

When performing work on the manipulator or controller, the following safety procedures and warnings must be observed.

- Maintain the safety settings of the software during maintenance work.
- If a particular part is defective, replace it with a new identical part or part approved by Doosan Robotics.
- The replaced part must be returned to Doosan Robotics.
- After completing the work, resume the safety function.
- Document the repair history of the robot system and manage related technical documents.
- Disconnect the power cable and make sure other power sources connected to the manipulator or controller do not supply power.
- Do not connect the system to a power source during maintenance.
- Check the ground connection before supplying power to the system.
- When disassembling the manipulator or controller parts, observe ESD regulations.
- Do not disassemble areas that supply power within the controller. Power supply areas may still be charged with high voltage (up to 600V) even after the controller is turned off.
- Take caution to prevent water or dust from entering the system during maintenance.

3.6 Disposal and Environment

Doosan Robotics products comply with the Restriction of Hazardous Substances of Directive 2011/65/EU & Directive (EU)2015/863.

Since the products contain industrial waste materials, improper disposal can cause environmental pollution. Therefore, do not dispose of the product along with general industrial or household waste.

When disposing of all or part of the product, you must comply with the laws and regulations of the country, and contact the seller or Doosan Robotics for detailed information related to the disposal.

Sellers in Europe must register data applicable to the country of sale to EWRN (<https://www.ewrn.org/national-registers>) in accordance with Directive 2012/19/EU – Waste Electrical and Electronic Equipment.

4 PART 4. User Manual

The user manual describes how to operate the system, how to configure settings, and how to operate the robot manually/automatically.

4.1 System Power On/Off

4.1.1 When using a teach pendant

Press and hold the power button on the upper left of the teach pendant.

i Note

If the system does not power up, check the power switch at the bottom of the controller. For details, refer to [Power On/Off Controller Switch](#)(p. 192).

- The power for systems such as the robot, controller and teach pendant is turned on.
- Once the system is powered on, the LED indicator for the robot lights up.
- Press the shutdown button on the teach pendant or press and hold the power button on the upper left of the teach pendant for 2 seconds.
 - a. The shutdown popup is displayed on the screen.
 - b. Press the OK button on the shutdown popup to properly shutdown the system.

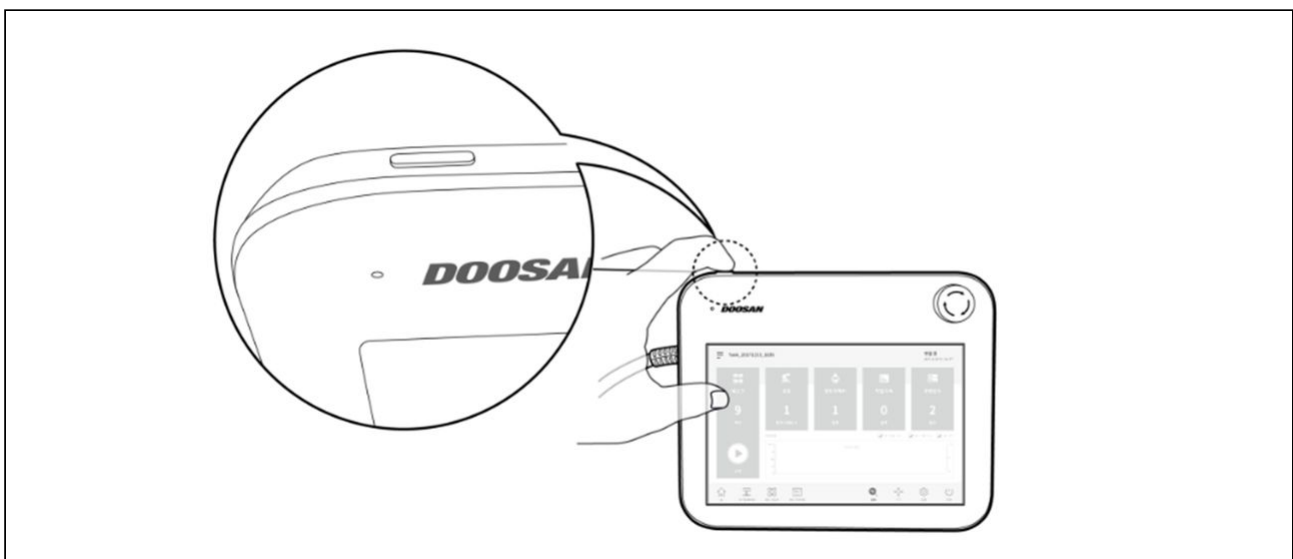

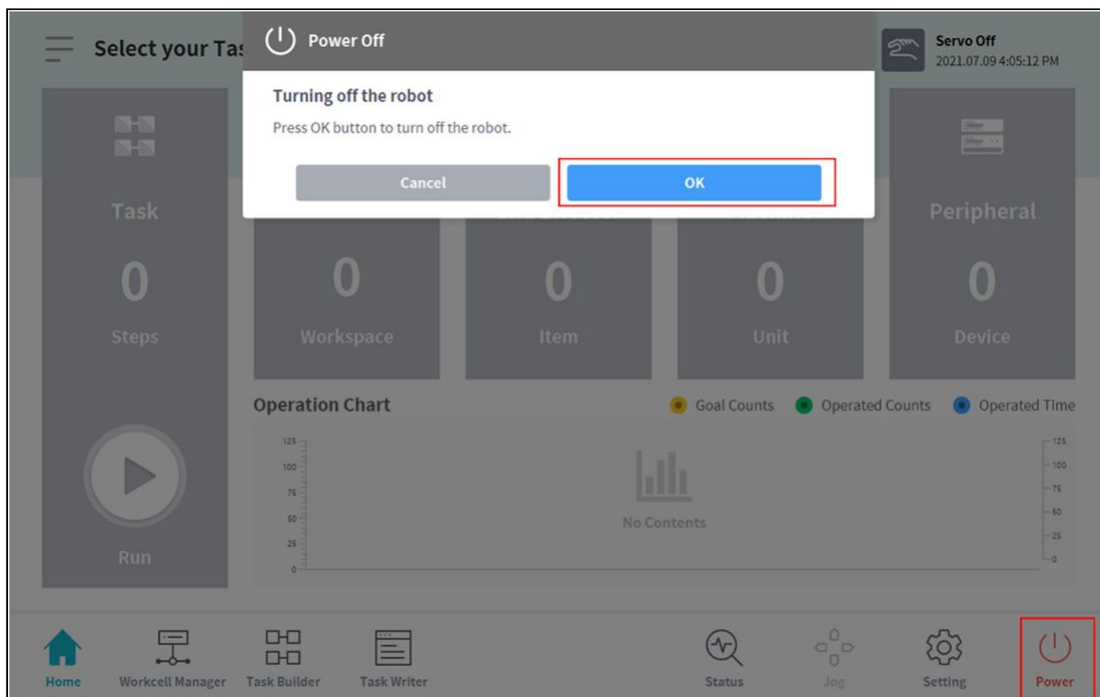

Warning

- Press and hold the power button for more than 4 seconds to force system shutdown.
- Forced shutdown may cause robot and controller failure.

4.1.2 System Booting

After the system is powered on, the system boots up. When booting is complete, the system application is displayed on the teach pendant. For more information about the system application, refer to [Program screen configuration](#) (p. 226).

In case of DART-Platform (for Windows),

1. Run the DART-platform installed on the desktop or laptop.
2. Wait about 5 minutes for the robot controller to finish booting.
3. When the IP is searched, check the serial number of the robot connected to the network.
4. Select the robot you want to connect and click the 'Connect' button.
5. Press the Force Recall button to transfer the control.

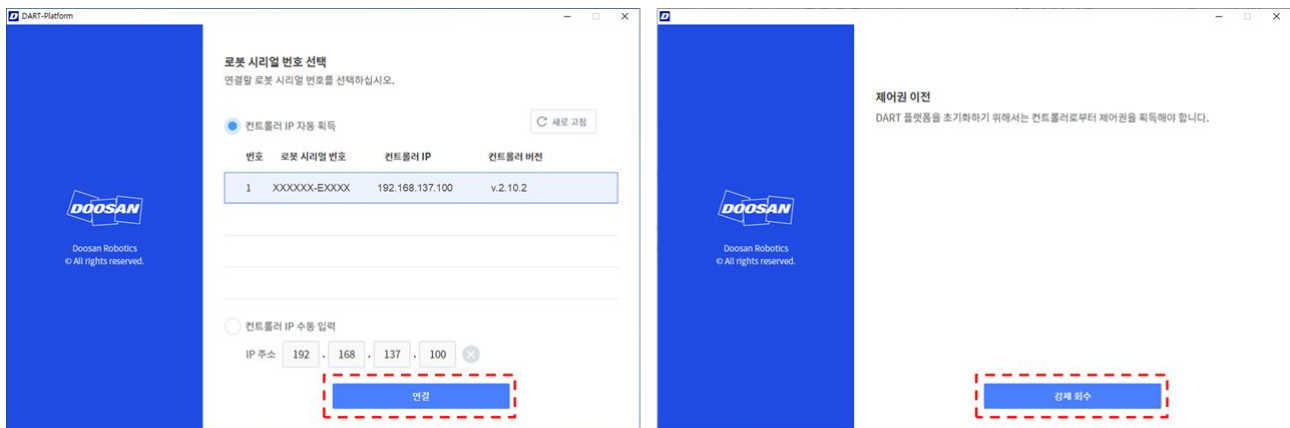

Note

- If there is no connection between the controller and DART-Platform, change the C class band of IP address and default gateway of the desktop or laptop with DART-Platform installed to the C class band of the controllers IP address, and retry.
- If the IP is not searched, select 'Enter the Controller IP Manually' and proceed with the connection. The controller's default IP address is set to 192.168.137.100.
- If the Forced Withdrawal of the control continues to fail, check the following:
 - a. Close the program and restart.
 - b. Ensure the Emergency Stop Button(s) is(are) not pressed.
 - c. If one or more pairs of digital inputs of the controller are designated to the Emergency Stop / Remote Emergency Stop / STO signal (Active Low) in Safety I/O setting, ensure all designated signal(s) is(are) deactivated (High).
 - d. Check whether the controller has finished booting.
 - e. Check the robot status. In case of Remote Control, Recovery, or Backdrive, running DART-platform may fail.

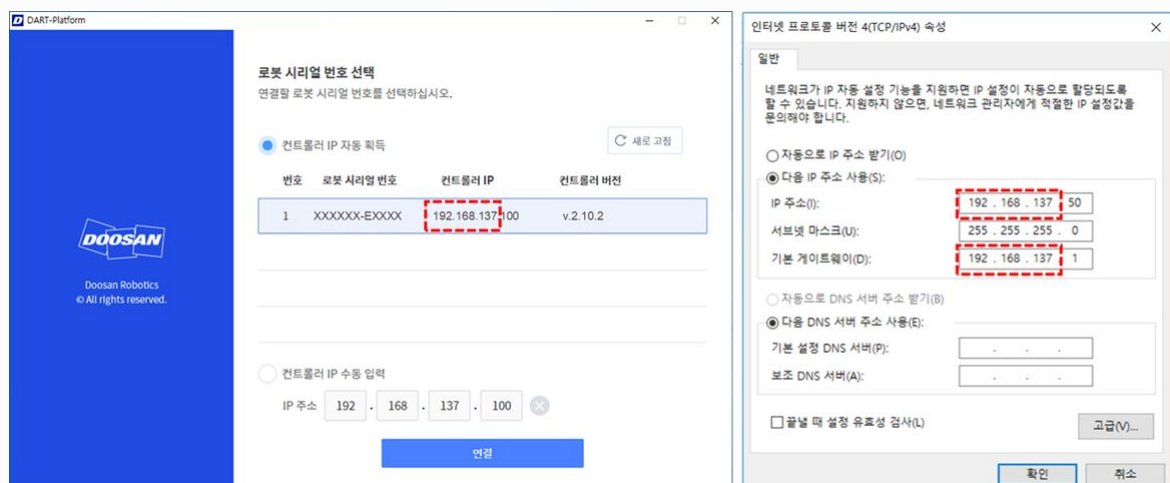

Note

- **Servo On:** In order to move the robot's pose, the robot must be in servo on status where power is supplied to joints of the robot and the robot is on standby. For more information about servo on, refer to [Servo On](#)(p. 240).
- **Date and Time Setting:** The date and time displayed on the teach pendant and the log message saved on the robot follow the date and time setting of the system, so the date and time must be configured at initial boot up. For information regarding how to configure the date and time, refer to [Date and Time Setting](#)(p. 354).
- Using the DART Platform allows robot control without the teach pendant.
- The DART Platform displays a screen that shows the robot connected to the network after booting, and the process of checking the robot's serial number and connecting to the robot take place on this screen.

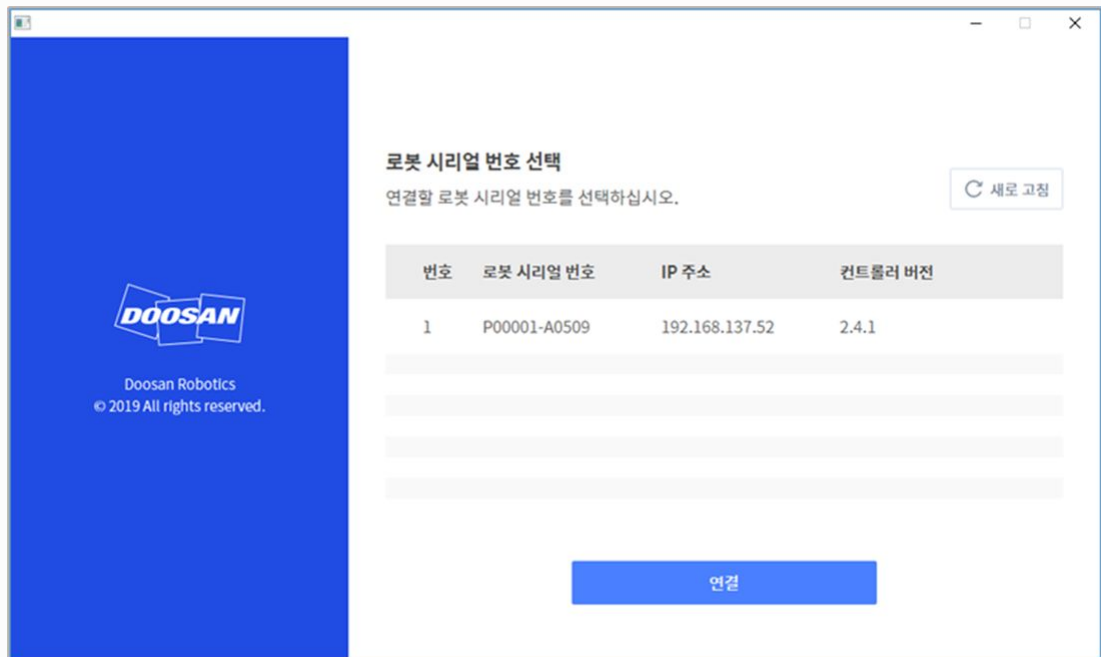

4.2 Program screen configuration

The UI of the system operation program consists of the following:

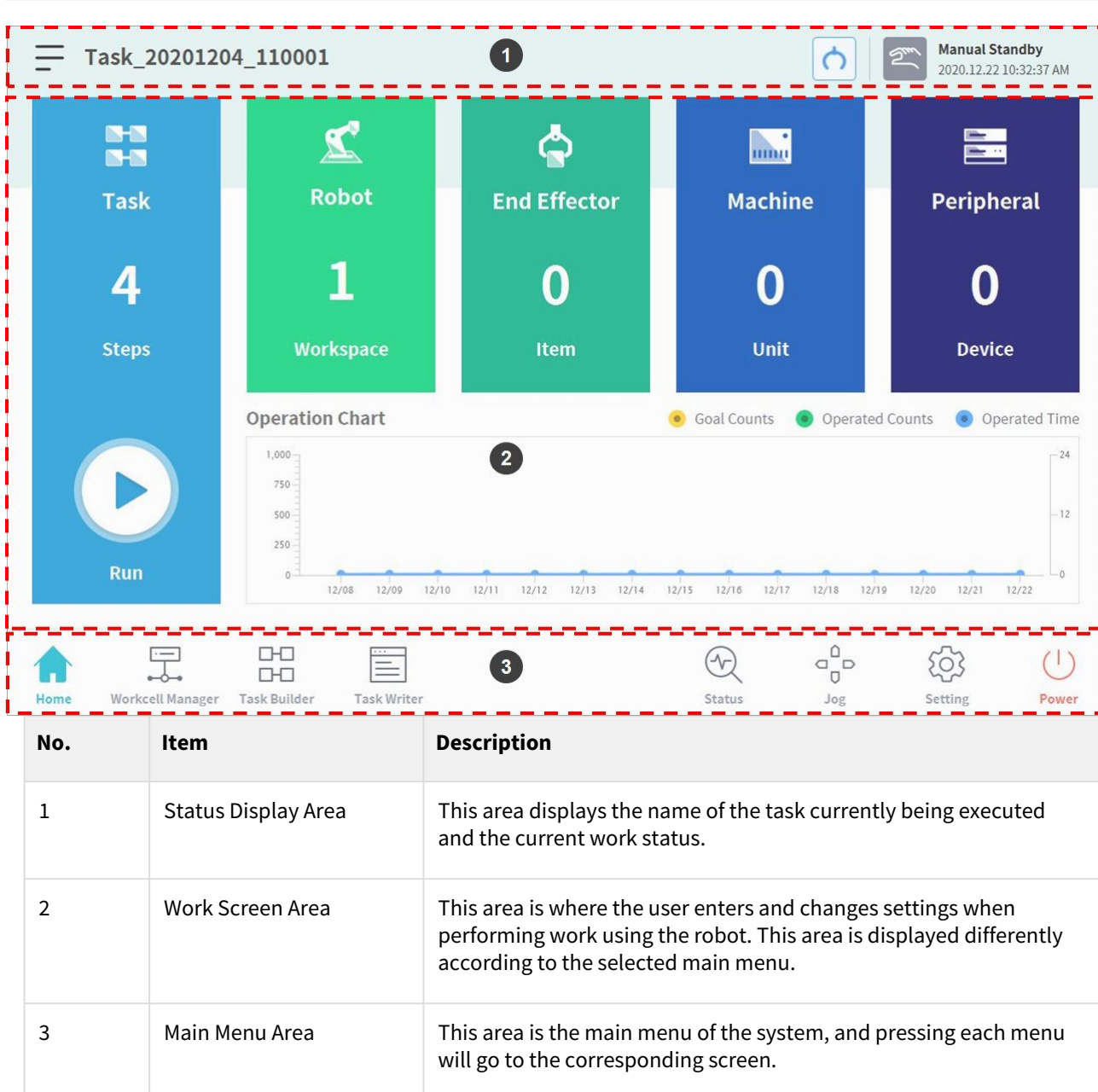

4.2.1 Home Screen Overview

Information about the current task status and task, and work progress graphs are displayed.

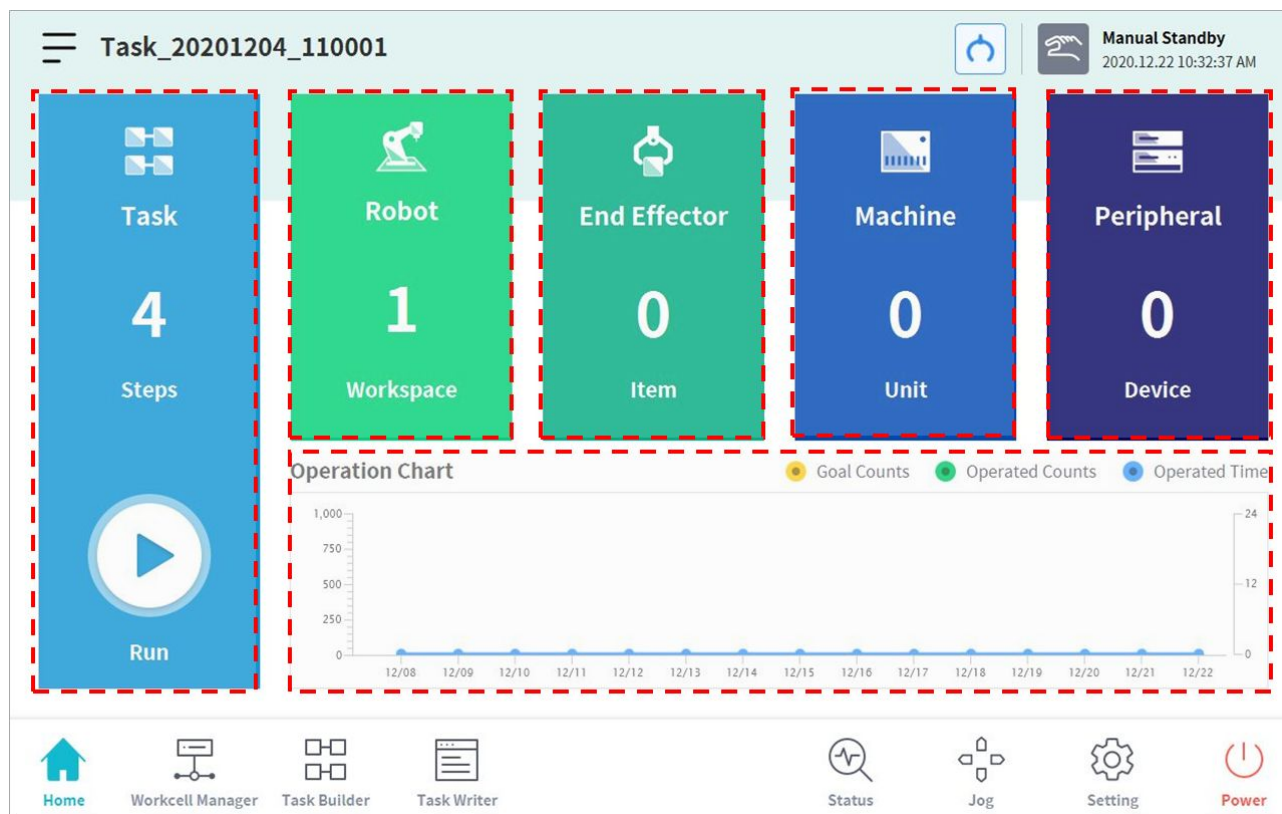

Item	Description
Task	<p>The total number of lines of the task program is displayed.</p> <p>Tapping the number indicating the program line will go to Task Builder or Task Writer.</p> <p>Tapping the  Execute button will go to a screen showing the opened task. For more information about the task execution screen, refer to Task Execution and Stopping(p. 352).</p>
Robot	<p>Displays the number of settings of the robot work space. Tap this item to go to the robot item setting screen of the Workcell Manager. For more information about the robot, refer to Robot Setting(p. 253).</p>
End Effector	<p>Displays the number of end effectors connected to the robot. Tap this item to go to the end effector setting screen of Workcell Manager. For more information about end effectors, refer to End Effector Setting(p. 279).</p>
Machine	<p>Displays the number of machines used in the task. Tap this item to go to the machine setting screen of Workcell Manager. For more information about the robot, refer to Machine Tool Setting(p. 285).</p>
Peripherals	<p>Displays the number of peripherals connected to the task. Tap this item to go to the peripheral setting screen of Workcell Manager.</p> <p>For more information about peripherals, refer to Peripheral Setting(p. 286).</p>

Item	Description
Work Status	Displays the target number , work count , and time of the current task. The information displayed can be selected using checkboxes.

4.2.2 Status window

To check or test the I/O information, tap the **Status** button in the main menu.

The **Status** window allows you to check the I/O information of devices connected to the controller and flange, and the **Backdrive** mode and **Safety Recovery** function can be executed.

The **Status** window is a popup window, so it is possible to tap the **Status** button on the **Home**, **Task Builder** or **Task Writer** screen even during Auto mode to check I/O information. The output test cannot be performed during Auto mode.

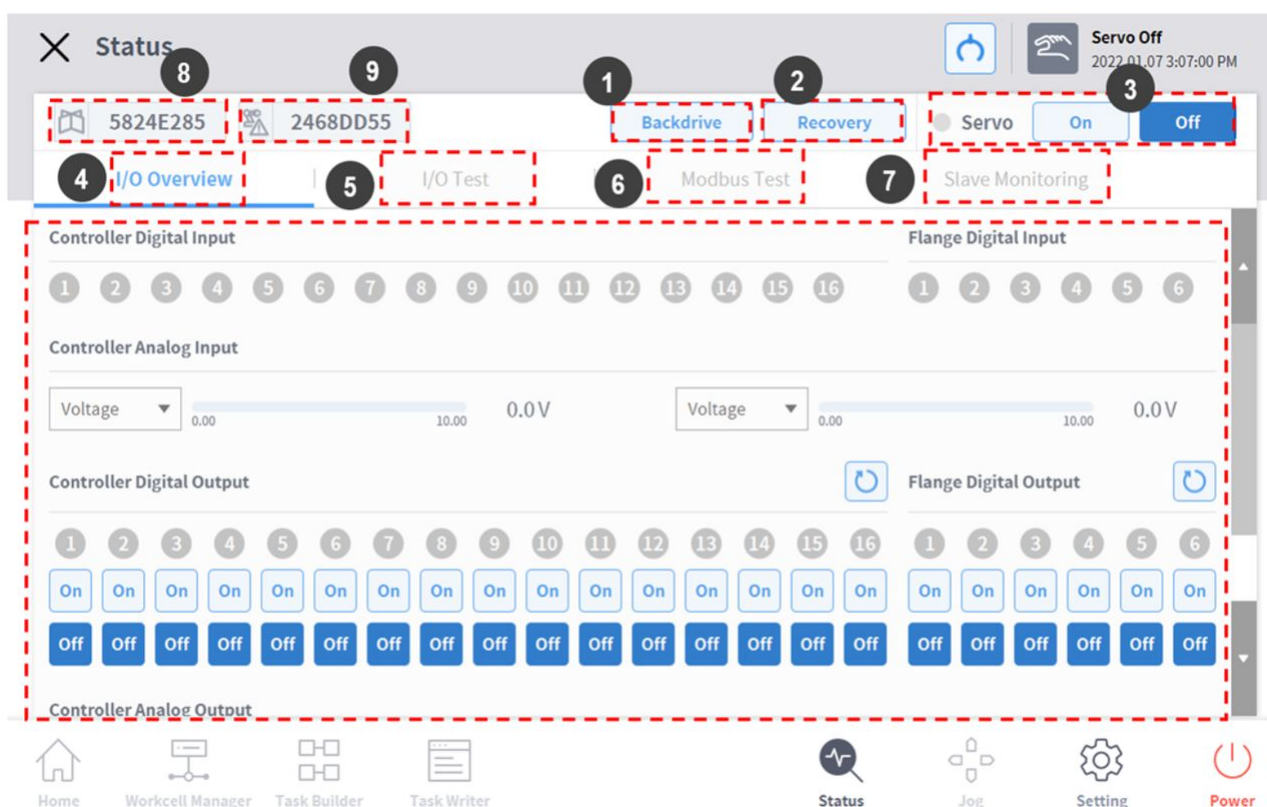

No.	Item	Description
1	Backdrive	If the robot is stopped due to an abnormality during operation, the user can cut the power to each joint and move the joint to the desired position manually to recover the normal operation status.

No.	Item	Description
2	Safety Recovery	Sets the robot angle and position when setting the robot in software recovery mode and packaging mode.
3	Servo On	Supplies the driving power that moves each joint of the robot.
4	I/O	Manages the digital and analog I/O status of the controller and flange.
5	I/O Test	Checks and tests the digital and analog I/O devices of the controller and flange used by the task.
6	Modbus Test	Tests the signals of the set Modbus device.
7	Slave Monitoring	Monitors all slave functions provided by Industrial Ethernet Slave (PROFINET, EtherNet/IP, Modbus).
8	Job Space Status Value	Displays encryption of the entire job space data registered to check whether the job space setup has been modified.
9	Safety Setup Status Value	Displays encryption of the entire safety data registered to check whether the safety setup has been modified.

4.2.3 Status Display Area

The status display area displays the current robot status and the opened task. The items displayed in the area may vary according to the screen displayed.

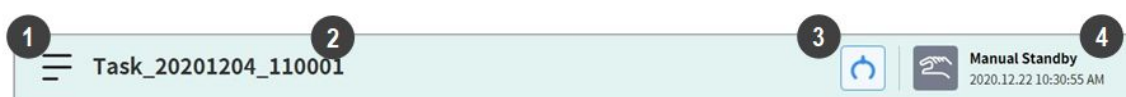

No.	Item	Description
1	Menu	Tap the Menu button to create a new task, or save or load a task currently being edited. The functions displayed when the menu button is tapped vary according to the screen displayed.
2	Task Name	The name of the task currently being executed is displayed.
3	Tool Setting Button	It runs the Tool Setting popup. refer to Tool Setting (p. 287).

No.	Item	Description
4	Robot State	The current work status and time of the robot are displayed.

**Note**

Check the robot state shown in the status display area. The information can be used as a reference when performing work using the robot. Refer to [Robot Mode and State](#)(p. 15).

4.2.4 Work Screen Area

The screens displayed on the work screen vary according to the main menu selected by the user.

**Note – Status, Jog, Setting Popup Window**

The **Status**, **Jog** and **Settings** screens are displayed in popup windows for operation convenience, and tapping the button in the popup window will return to the edit screen prior to the popup window. Pressing the **Workcell Manager**, **Task Builder** or **Task Writer** button on the main menu without closing the popup window using the button on the **Status**, **Jog** or **Settings** screen will enter a new screen rather than returning to the previous screen.

4.2.5 Main Menu

Major functions of the system can be checked in the main menu. Tap each menu button to go to the corresponding menu screen.



- **Home:** It is the initial screen of the system, and information and a work progress graph of the current task are displayed. For more information about home, refer to [Home Screen Overview](#)(p. 227).
- **Workcell Manager:** Robots and peripherals can be added to the task and managed. For more information about the Workcell Manager, refer to [Utilizing Workcell Manager](#)(p. 252).
- **Task Builder:** Commands provided by the system can be added or deleted to configure a single task. For more information about Task Builder, refer to [Task Builder](#)(p. 316).
- **Task Writer:** Advanced users can configure a single task by adding, editing or deleting commands to be used in the task. For more information about the Task Writer, refer to [Task Writer](#)(p. 344).
- **Status:** The I/O status of devices connected to the robot and controller can be checked. For more information about the status, refer to [Status window](#)(p. 229) & [I/O and Communication](#)(p. 241).
- **Jog:** The robot can be moved to or aligned with a specific point using the jog button. For more information about jog, refer to [Jog Function](#)(p. 288).
- **Setting:** System-related settings, such as language, password and network, can be configured. For more information about setting, refer to [Environment Setting](#)(p. 354).
- **Power:** Power to the system can be turned off.

Note – Disabling Main Menu Button

When the robot is in Servo Off or in Auto mode, some of the main menu becomes disabled, limiting user operation.

- **Servo Off:** In Servo Off, main menu buttons other than **Home, Status, Settings** and **Power** are disabled. To change from Servo Off to Servo On, tap the **Status** button on the main menu and tap the **Servo On** button on the **Status**. When the robot is in Servo On, **Workcell Manager, Task Builder, Task Writer** and **Jog** buttons are enabled.
- **Auto Mode:** This is the mode where the robot is operated automatically according to the user's task. Main menu buttons other than the **Status** and **Power** buttons are disabled. Stopping the current task will enable all buttons.

Screen Information not updated when transferring control from certain screens

- When transferring control between Windows and Teach Pendant from the same screen, the information saved on one screen is not automatically reflected in the other device until reloading is performed.

4.3 Understanding the robot

The operation modes of the robot consist of manual mode, where the user controls the robot directly, and auto mode, where the robot operates without direct user control. For more information, refer to [Robot Mode and State](#)(p. 15).

The color or illumination of the LED changes according to the robot status. For more information, refer to [Status and Flange LED Color for Each Mode](#)(p. 16).

4.3.1 What is Euler Angle A, B, C?

Euler Angle is a way to express the angles of X, Y and Z axes, which are perpendicular among themselves in the object direction. A, B and C refer to the sequential rotation angles. Each robot manufacturer defines this A, B and C rotation order differently, such as **Rz-Ry-Rx** or **Rx-Ry-Rz**.

Doosan Robotics uses **Rz-Ry-Rz**. Here, **Rz** means the rotation in Z-axis, and **Ry** means the rotation in Y-axis. Rz can be expressed as angle A, Ry as angle B, and Rz as angle C to indicate the current rotating direction of an object. Note that once rotation is made in Z-axis direction from the coordinates, rotations will be made based on new coordinates.

This can be visualized with steps 1 to 4.

1. Assume there are coordinates (X, Y, Z).

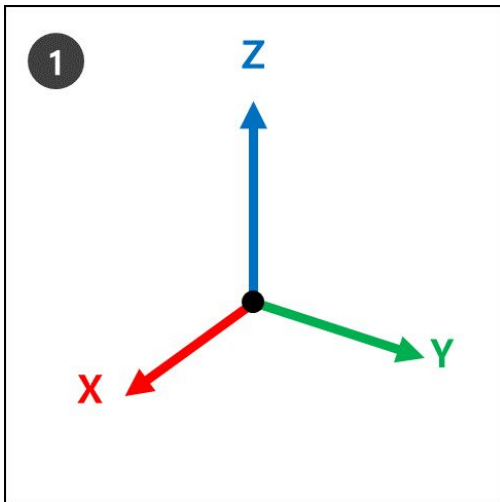

2. **R_Z**: Rotate by A degrees from the Z-axis.

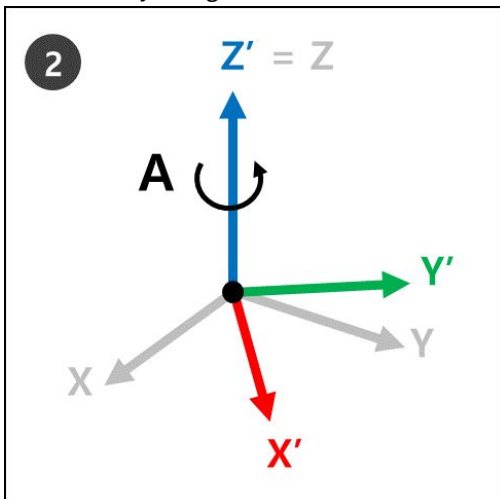

3. **R_y** : Rotate by B degrees from the new Y-axis (Y') of the new coordinates (X', Y', Z') in step 2.

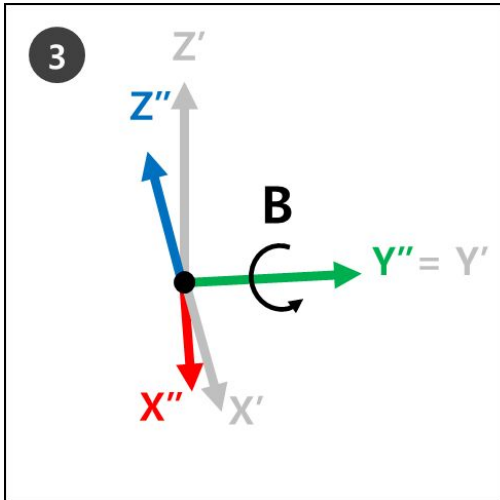

4. **R_z** : Rotate by C degrees from the new Z-axis (Z'') of the new coordinates (X'', Y'', Z'') in step 3.

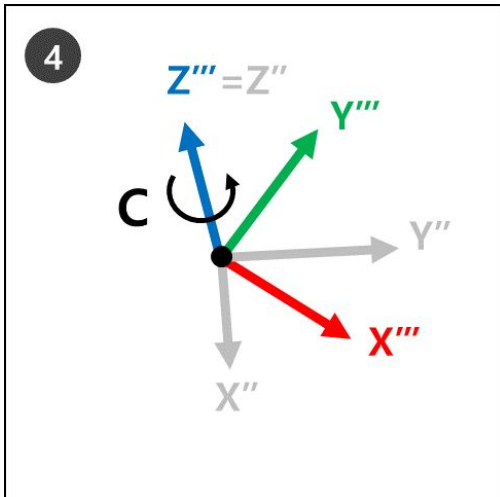

5. The new coordinates (Z''' , Y''' , X''') of step 4 refers to the current robot rotation when Euler Angles A, B and C are applied.

This can be easily visualized with one's right hand. Make the following pose with your right hand. This is called the Right-Hand Rule, and making the thumb (X-axis), index finger (Y-axis) and middle finger (Z-axis) to be perpendicular to each other will create coordinates consisting of X, Y and Z axes.

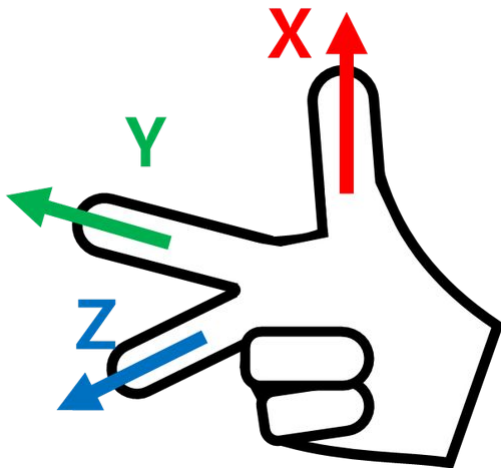

Then make the Right-Hand Rule Cartesian pose and make rotations R_z , R_y and R_z in sequential order.

1. R_z : Rotate the middle finger (Z-axis) by A degrees.
2. R_y : Rotate the index finger (Y-axis) by B degrees.
3. R_z : Rotate the middle finger (Z-axis) by C degrees.

Note

The + rotating direction of A, B and C is the direction of four fingers except the thumb, when the thumb is pointing at the + direction and the four fingers are clenched. This is called the Law of Clockwise Screw.

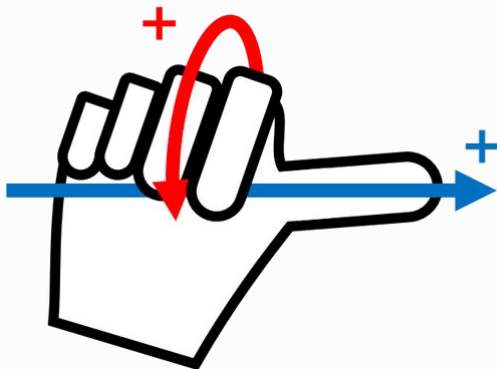

4.3.2 What is Singularity?

Singularity in a multi-joint robot refers to a position (or point) where the robot has difficulty in calculating its next pose during moving. Multi-joint robots calculate each joint angle during movement based on the robot end.

For example, in Fig. 1 below, when the robot is moving to the red dot, the robot will not be able to determine whether to move its joints to set pose A or pose B as shown in Fig. 2. This position (or point) is called the singularity.

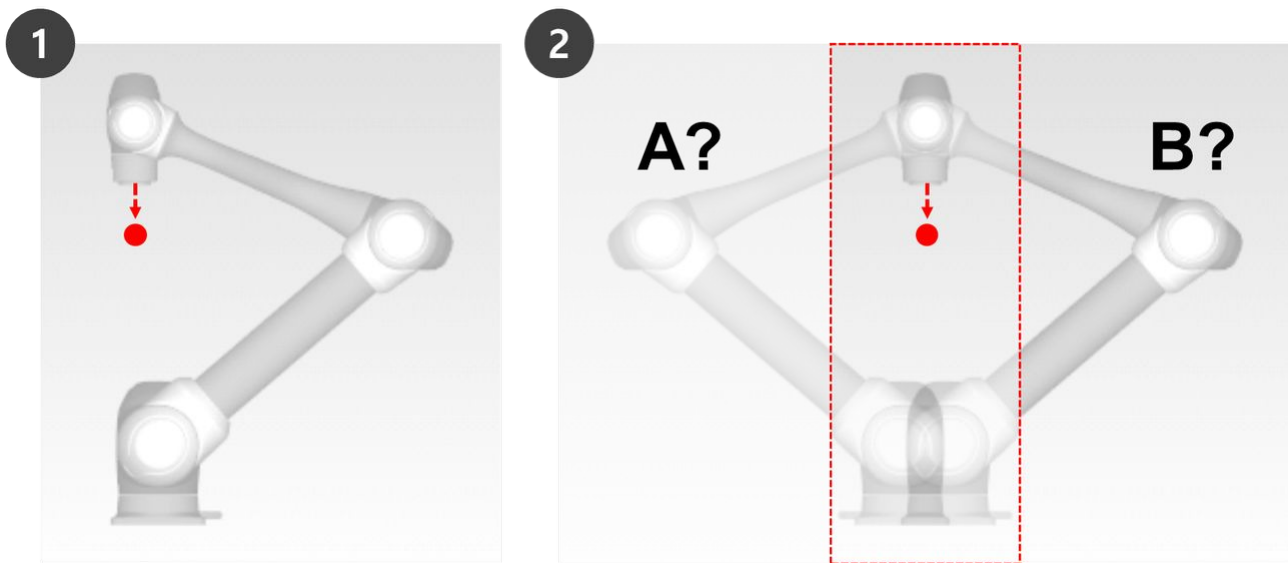

Near a singularity, robot movement is not fluid in terms of plane, point and line, robot end linear movement may not be maintained, and position error during control may increase. Singularity occurs in three cases as shown in the following figure, including when the robot joints form a line.

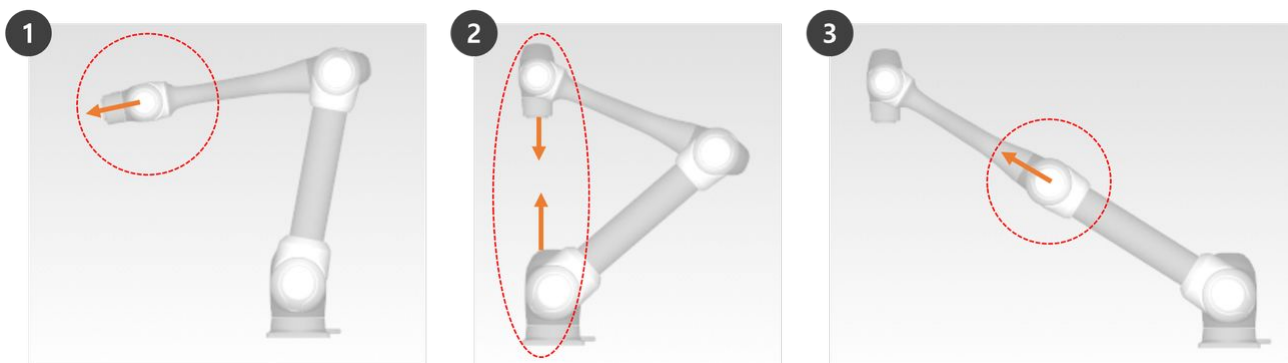

1. Wrist Singularity: When the robot wrist forms a line as Axis 5 approaches 0°
 - When compared to a human arm, Axes 4, 5 and 6 correspond to the wrist joint.
2. Shoulder Singularity: When Axes 1 and 6 are on the same line
 - When compared to a human arm, Axes 1 and 2 correspond to the shoulder joint.
3. Elbow Singularity: When the robot forms a line as Axis 3 approaches 0°
 - When compared to a human arm, Axis 3 corresponds to the elbow.

Caution

- Manual and automatic operations moving with joint rotation are not influenced by singularity.
 - Joint movement, MoveJ commands, etc.
- Singularity only occurs during manual and automatic operation where the robot ends performing linear movement.
 - Task movement, MoveL command, etc.
- In the singularity zone, force control or compliance control is unavailable.

- As the rotation speed of certain axes increase rapidly when a linear motion passes a singularity, it is possible for a Joint Speed Limit Violation or Joint Angle Limit Violation to occur.

How to avoid Singularity

Doosan Robotics robots offer options to avoid singularities during motion control. However, it is recommended to configure a task that does not create exceptions using joint movement commands such as MoveJ in singularity zones.

Here are the singularity avoidance options provided by Doosan Robot:

- Automatic avoidance: Performs motion by avoiding singularities. However, the robot motion may differ from the expected path.
- Path priority: Maintains path and speed, but may stop due to an error near a singularity.
- Variable speed: Maintains path, but decelerates near a singularity.

4.3.3 Functional Limits of each Robot Series

The different robot series (A, As, E, M/H, P Series) limit the use of functions as follows:

- **Current-based:** Current of motor located on each joint is used.
- **FTS-based:** An FTS (force torque sensor) located on the end of the robot is used.
- **JTS-based:** JTS (joint torque sensors) located on each joint is used.

Features	A/E Series (Current-based)	A Series S (Current, FTS-based)	M Series (JTS-based)	H Series (JTS-based)	P Series (JTS-based)
Direct Teaching - Free Motion	O	O (Current-based)	O	O	O
Direct Teaching - Restrained Motion	X	O (FTS based)	O	O	O
Collision Detection	O	O (Current-based)	O	O	O
Installation Pose Measurement	X	O (FTS based)	O	X(the robot can only be installed on the floor)	X(the robot can only be installed on the floor)

Features	A/E Series (Current-based)	A Series S (Current, FTS-based)	M Series (JTS-based)	H Series (JTS-based)	P Series (JTS-based)
Tool Weight Measurement	X	O (FTS based)	O	O	O
Workpiece Weight Measurement	X	O (FTS based)	O	O	O
Nudge Function	X	X	O	O	O
Force Control	O (setting available only in three translation directions, excluding rotation)	O (FTS based)	O	O	O
Compliance Control	O (setting available only in three translation directions, excluding rotation)	O (FTS based)	O	O	O

Functional Limits of force monitoring for each Robot Series

You can use the teach pendant and DART-Studio to monitor force data. You may also use the DRL command (`check_force_condition()`) to monitor force data externally.

- **If the palletizing mode is set to “ON”:** The same control/monitoring functions provided in the OFF state are available, except for H, P Series robots.

Features	A/E Series (Current-based)	A Series S (Current-based and FTS-based)	M Series (JTS-based)	H Series (JTS-based)	P Series (JTS-based)
Force control	O (setting available only in three translation directions, excluding rotation)	O (FTS-based)	O	O	O
				O (If the palletizing mode is set to "ON": Force control output limited (Base Rx, Ry orientation) ¹⁾)	O (If the palletizing mode is set to "ON": Force control output limited (Base Rx, Ry orientation) ¹⁾)
Compliance control	O (setting available only in three translation directions, excluding rotation)	O (FTS-based)	O	O	O
				O (If the palletizing mode is set to "ON": Compliance control output limited (Base Rx, Ry orientation) ¹⁾)	O (If the palletizing mode is set to "ON": Compliance control output limited (Base Rx, Ry orientation) ¹⁾)
Force monitoring (Teach Pendant)	X	O (FTS-based)	O (Force value of "0" shown for the singularity section)	O (Force value of "0" shown for the singularity section)	O (Force value of "0" shown for the singularity section)
				O (If the palletizing mode is set to "ON": 4-Degree of Freedom provided for the base (x, y, z, Rz))	O (If the palletizing mode is set to "ON": 4-Degree of Freedom provided for the base (x, y, z, Rz))
Force monitoring (DART-Studio)	O (Force value of "0" shown for the singularity section)	O (FTS-based)	O (Force value of "0" shown for the singularity section)	O (Force value of "0" shown for the singularity section)	O (Force value of "0" shown for the singularity section)

Features	A/E Series (Current-based)	A Series S (Current-based and FTS-based)	M Series (JTS-based)	H Series (JTS-based)	P Series (JTS-based)
				O (If the palletizing mode is set to "ON": 4-Degree of Freedom provided for the base (x, y, z, Rz))	O (If the palletizing mode is set to "ON": 4-Degree of Freedom provided for the base (x, y, z, Rz))
Force monitoring (When using DRL commands: check_force_condition())	O (Force value of "0" shown for the singularity section)	O (FTS-based)	O (Force value of "0" shown for the singularity section)	O (Force value of "0" shown for the singularity section)	O (Force value of "0" shown for the singularity section)
				O (If the palletizing mode is set to "ON": 4-Degree of Freedom provided for the base (x, y, z, Rz))	O (If the palletizing mode is set to "ON": 4-Degree of Freedom provided for the base (x, y, z, Rz))

Control output restriction (Base Rx, Ry orientation): The force or compliance control value for the Base Rx or Ry orientation has not been output. Entering the force or compliance control value of the relevant axis (Base Rx, Ry) will have no effect, and will be ignored as "0."

4.4 Servo On

Servo On refers to the standby status where the robot arm can be operated by supplying power to joints. Pressing the emergency stop button or violating critical safety limits sets the Servo Off status. During servo off status, the power to joints is cut off, which results in the robot arm being unable to be operated, and **Workcell Manager, Task Builder, Task Writer** and **Jog**, which are related to robot arm operation, are disabled in the main menu.

To change from Servo Off to Servo On, tap the **Status** button on the main menu and tap the **Servo On** button on the top right.



To shift from **Servo On** to **Servo Off**, tap the Status button of the main menu and tap the **Servo Off** button in the top right corner of the screen.

**Note**

In the **Settings** screen, if the safety signal I/O, POS_3_ENABLE_SWITCH, is set, **Servo On** is available only if this signal is inputted.

**Caution**

Neglecting to verify the payload and associated settings can result in injury to personnel and/or property damage. Always verify the actual payload and settings are correct before 'servo on' and operation of robot.

4.5 I/O and Communication

4.5.1 I/O Status Check

Controller/Flange Digital Input Check

Old Flange

Controller Digital Input	Flange Digital Input
1 2 3 4 5 6 7 8 9 10 11 12 13 14 15 16	1 2 3 4 5 6

New Flange

Controller Digital Input	Flange Digital Input
1 2 3 4 5 6 7 8 9 10 11 12 13 14 15 16	1 2 3 4

1. Check the port number of the device connected to the controller or flange.
2. The following is displayed depending on the digital input status of the corresponding number.
 - If the digital signal is a high signal, the icon is displayed in light green.
 - If the digital signal is a low signal, the icon is displayed in gray.

**Note**

If the digital signal is High even when the digital input is set as the safety input, the icon is displayed in blue, and if it is Low, it is displayed in gray.

Controller/Flange Analog Input Check

Old Flange

Controller Analog Input



New Flange

Controller Analog Input

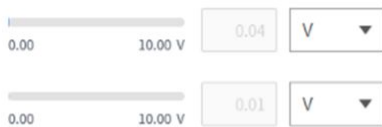

Controller Analog Output



Flange Analog Input

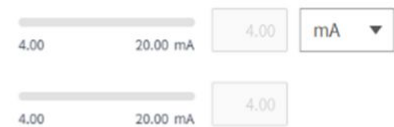

1. Press the drop-down list of the analog input of the controller/flange to select the item to check.
2. Check the analog input information of the selected item displayed on the screen.

Note

The analog input value cannot set the input value in the status window.

Controller/Flange Digital Output Setting

Old Flange

New Flange

Controller Digital Output



Flange Digital Output

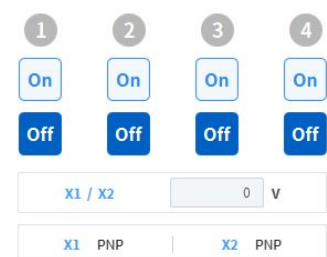

1. Check the port number of the device connected to the controller or flange.

2. Press the On/Off icon corresponding to the port number to activate or deactivate digital output.

- The icon changes to light green and the corresponding port is enabled when the **On** icon is pressed.
- The icon changes to light green and the corresponding port is disabled when the **Off** icon is pressed.

Controller/Flange Analog Output Setting

Old Flange

Controller Analog Output

New Flange

Controller Analog Input

Controller Analog Output

Flange Analog Input

1. Press the drop-down list of the analog output of the controller to select the item to set.

- Analog output information of the selected item is displayed on the right side of the drop-down list.
- The default value for analog output signals is voltage.

2. Modify the analog output value.

4.5.2 I/O Test

The screenshot displays the 'I/O Test' interface. At the top, there are status indicators for 'E48445E9' and '78700D95', along with 'Backdrive', 'Recovery', and 'Servo' controls. The 'I/O Test' tab is active, showing a 'Current Task' section with a task name 'Task_20201222_113737' and a 'Save Task' button. Below this, there are two informational messages. The 'Controller Digital Output' section contains a table with columns for 'Port Name', 'Test', 'No.', 'Port Name', and 'Test'. The first row is highlighted with a red dashed box and numbered 1. A 'Reset' button is located to the right of the table, numbered 6. The bottom navigation bar includes icons for Home, Workcell Manager, Task Builder, Task Writer, Status, Jog, Setting, and Power.

No.	Item	Description
1	Current Task	Displays the task currently being edited or executed.
2	Save Task	If changes are made to the task being edited, they must be saved in order to test the I/O device.
3	Port Number	It displays the port number used for testing the I/O device, and it is displayed when the signal is on.
4	Port Name	The port name of the I/O device for testing can be designated.
5	I/O Test	A signal can be sent to the corresponding port.
6	Initialization	Initializes all signals of the device as off.

4.5.3 Modbus Test

This is the menu to check and test Modbus signals set at Modbus TCP, Modbus RTU, and predefined Modbus.

No.	Item	Description
1	Modbus Type	Select the Modbus type to check. TCP, RTU, and predefined Modbus are available.
2	Slave	Displays the list of IPs/Ports of the slave set of the selected Modbus type. When selected, it displays a list of corresponding signals.
3	Signal List	Displays a list of signals set on the selected slave. Input and output signals can be checked.

4.5.4 Status > Slave Monitoring

It is the menu where monitoring for all Slave functions offered by the industrial Ethernet Slave (PROFINET, EtherNet/IP, Modbus) can be accessed.

The screenshot shows the 'Status' screen with the following elements:

- Slave Type:** A dropdown menu set to 'Modbus', highlighted with a red dashed box and labeled '1'.
- Monitoring Items Table:** A table with columns 'Type', 'Address', 'Value', and 'Description'. It contains two rows: 'Coil' and 'Holding register', both with address '0' and 'Signed Int' output type. The table is highlighted with a red dashed box and labeled '2'.
- Update & Start Button:** A blue button labeled 'Update & Start', highlighted with a red dashed box and labeled '3'.
- Information Message:** A message icon with a red dot and the text: "If you do not press the 'Update & Start' button, the entered items are not saved. Press the button below to save and start monitoring."
- Bottom Navigation Bar:** Includes icons for Home, Workcell Manager, Task Builder, Task Writer, Status, Jog, Setting, and Power.

No	Item	Description
1	Slave Type	Select the slave type to be monitored. Modbus, EtherNet/IP and Profinet are available.
2	Settings List	Monitoring items can be set by entering the type, address, output and description.
3	Update & Start	It can update monitoring setting information and start monitoring. Even if the slave type is changed after execution, each setting is maintained.

4.6 What is a Workcell Item?







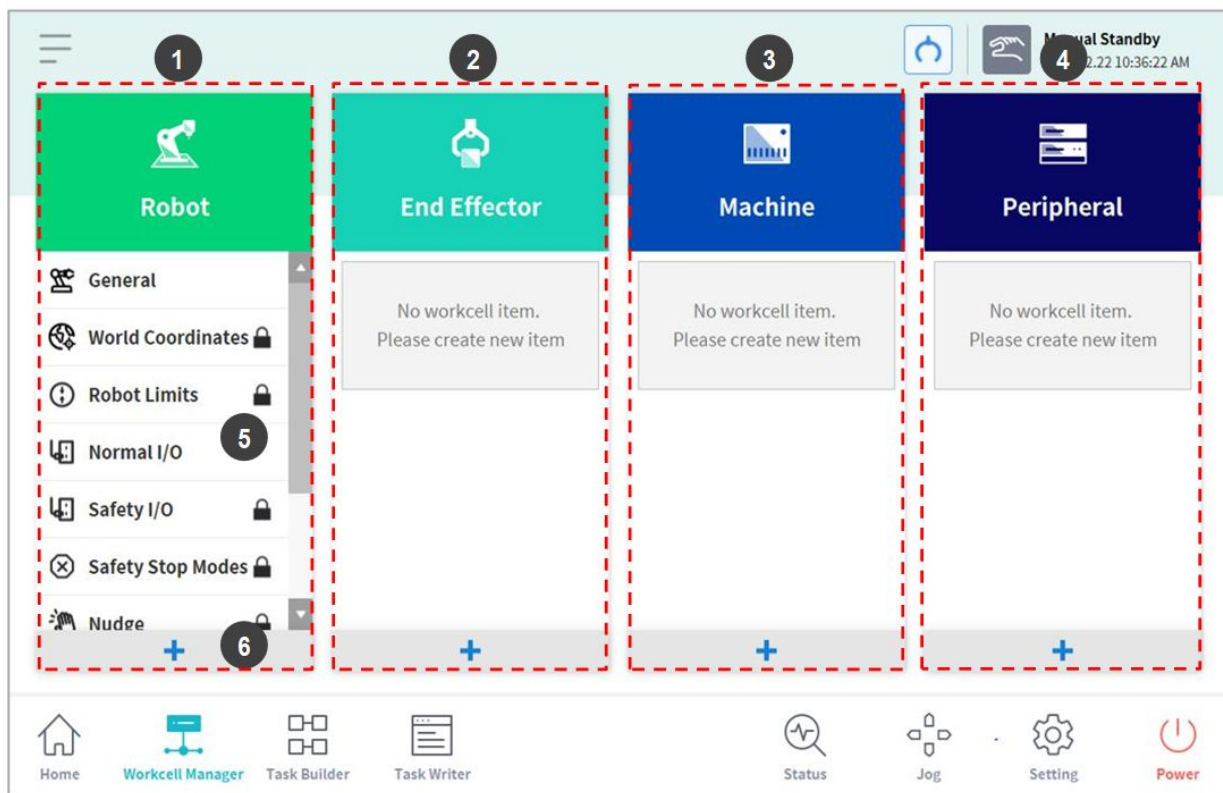



Workcell Item refers to the robot and all peripherals used together with the robot.

Workcell items can be configured in the Workcell Manager screen before use. Also, the *Workcell Manager* can set commands for peripherals and can configure commands for the robot to perform certain patterns and actions.

The following screen appears when the **Workcell Manager** in the main menu is tapped.



No	Item	Description
1	Robot	<p>Setting items related to the robot can be added and added setting items are displayed.</p> <ul style="list-style-type: none"> • General • World Coordinates • Robot Limits • Safety I/O • Normal I/O • Safety Stop Modes • System Variable • Robot installation pose • Tool weight • Tool shape • User Coordinates • Nudge • Space Limit • Collaborative Zone • Crushing Prevention Zone • Collision Sensitivity Reduction Zone • Tool Orientation Limit Zone • Custom Zone

No	Item	Description
2	End Effector	<p>End effectors can be added to the robot, and the added end effector is displayed.</p> <ul style="list-style-type: none"> •  Double-Action Gripper •  Single-Action Gripper •  Screwdriver •  Tool
3	Machine	<p>Machines compatible with the robot can be added, and the added machine is displayed.</p> <ul style="list-style-type: none"> •  Press machine •  Turning center •  Injection molding machine
4	Peripherals	<p>Peripherals connected to the robot can be added, and the added peripheral is displayed.</p> <ul style="list-style-type: none"> •  Pallet (4P) •  Conveyor •  Bolt feeder
5	Workcell Item Area	<p>List of Workcell items registered in each category is displayed. Selecting a Workcell item moves to the corresponding Workcell item setting screen.</p>
6	Add Workcell Item Button	<p>Adds a Workcell item to each category. Tap the add Workcell item button at the bottom of the category to go to the Workcell item select screen of the corresponding category.</p>

**Note**

Detailed explanations of various Workcell items provided by the Workcell Manager are provided in a reference manual.

4.6.1 Add Workcell Item

Tap the  add button at the bottom of each Workcell displayed on the initial screen of the Workcell Manager to display the Workcell category and type selection screen. Select the Workcell category and type to register, and tap the **Select** button to go to the corresponding Workcell setting screen.

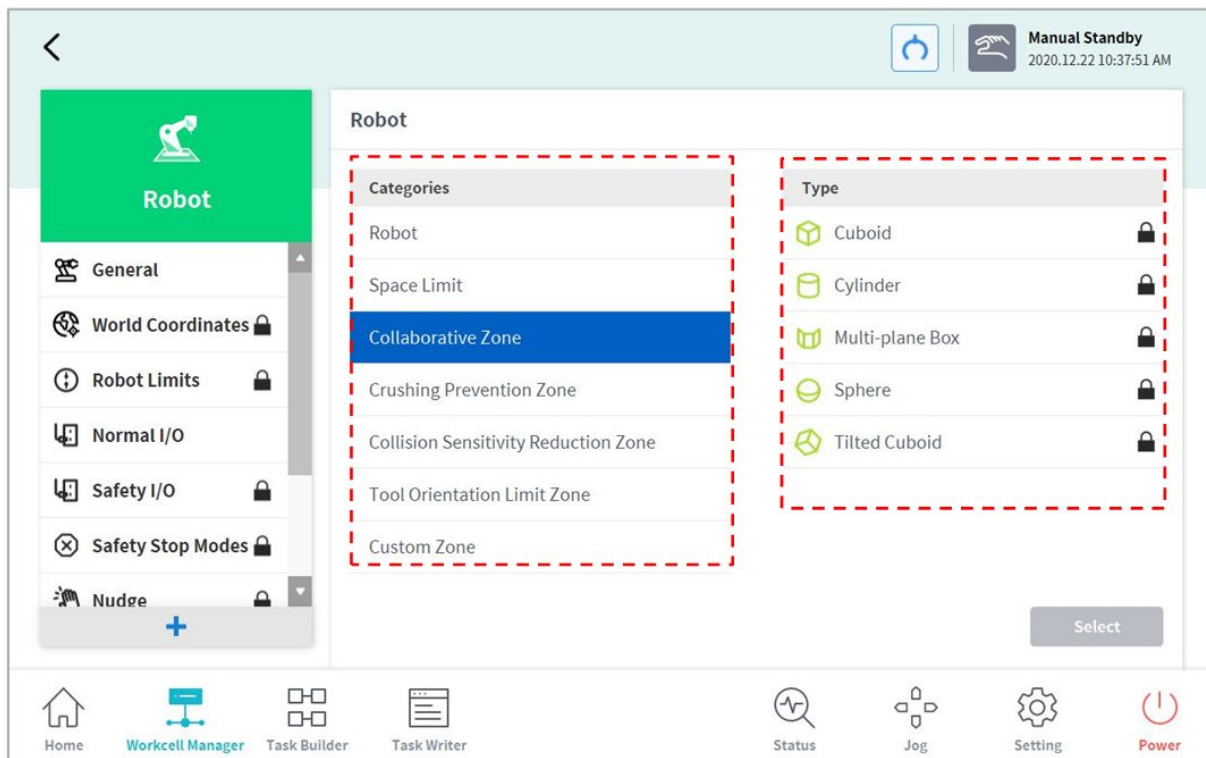

Note

The Workcell Item name must consist of 20 alphabet characters and numbers. The only special character allowed is the underscore, and the name cannot have blank space at the front or back.

4.6.2 Deprecated Workcell Item

Workcell items are managed in two states: Normal, where new items can be registered, and Deprecated, where maintenance is no longer possible.

Workcell Items can be updated due to increased usability and additional motion improvements. If a Workcell Item is updated, the existing Workcell Item becomes deprecated, and it cannot be added or edited. Deprecated Workcell Items are displayed as gray icons.

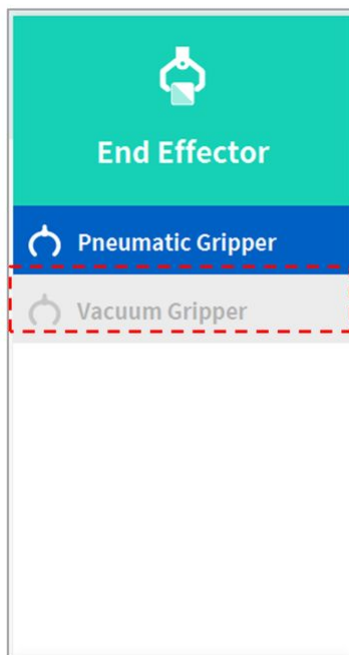

Deprecated Workcell Items cannot be added, but they can be used to view setting information and can also be used in the current task program. If a deprecated Workcell Item is selected, the setting information of the Workcell Item is displayed along with a message stating “**Deprecated Item.**”

Output Signal Controller

Name	Port No.
Grasp	3
Release	6

Input Signal Controller

Name	Port No.
Grasp Sensor	5
Release Sensor	10

Tapping the **Edit** button cannot edit the setting, but deletion is possible.

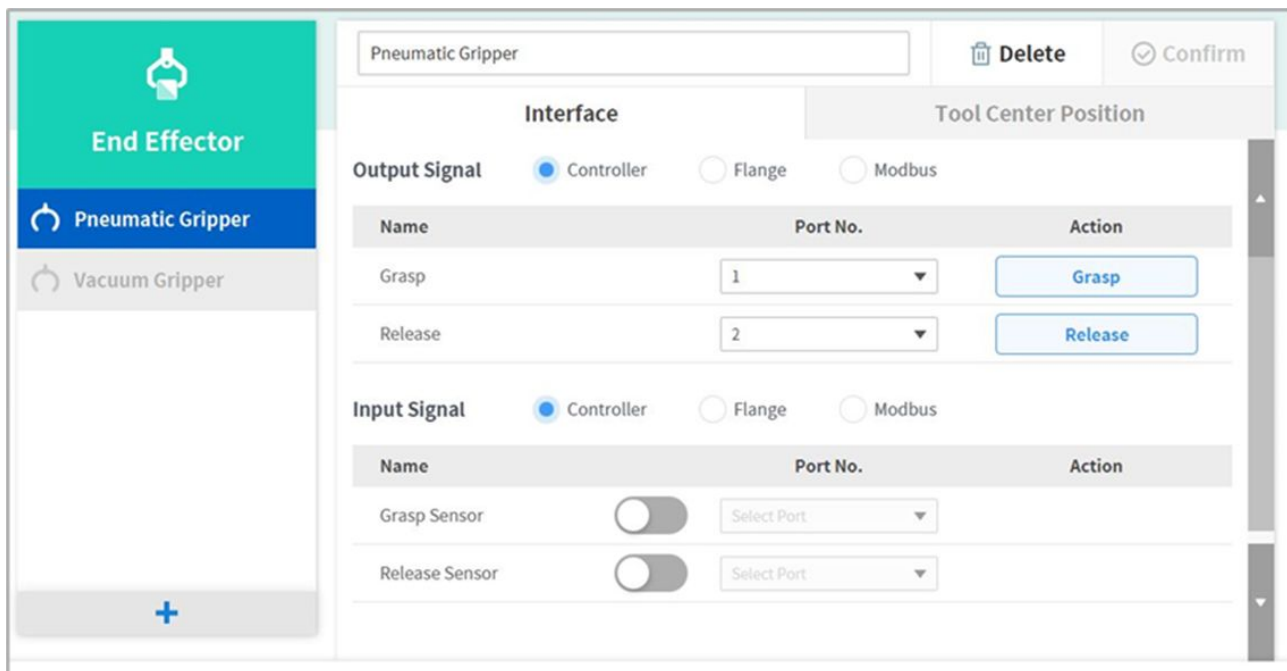

4.6.3 Unavailable Workcell Items

Any 3rd Party Workcell Item which is not installed or do not have a compatible version will be listed as an Unavailable Workcell Item.

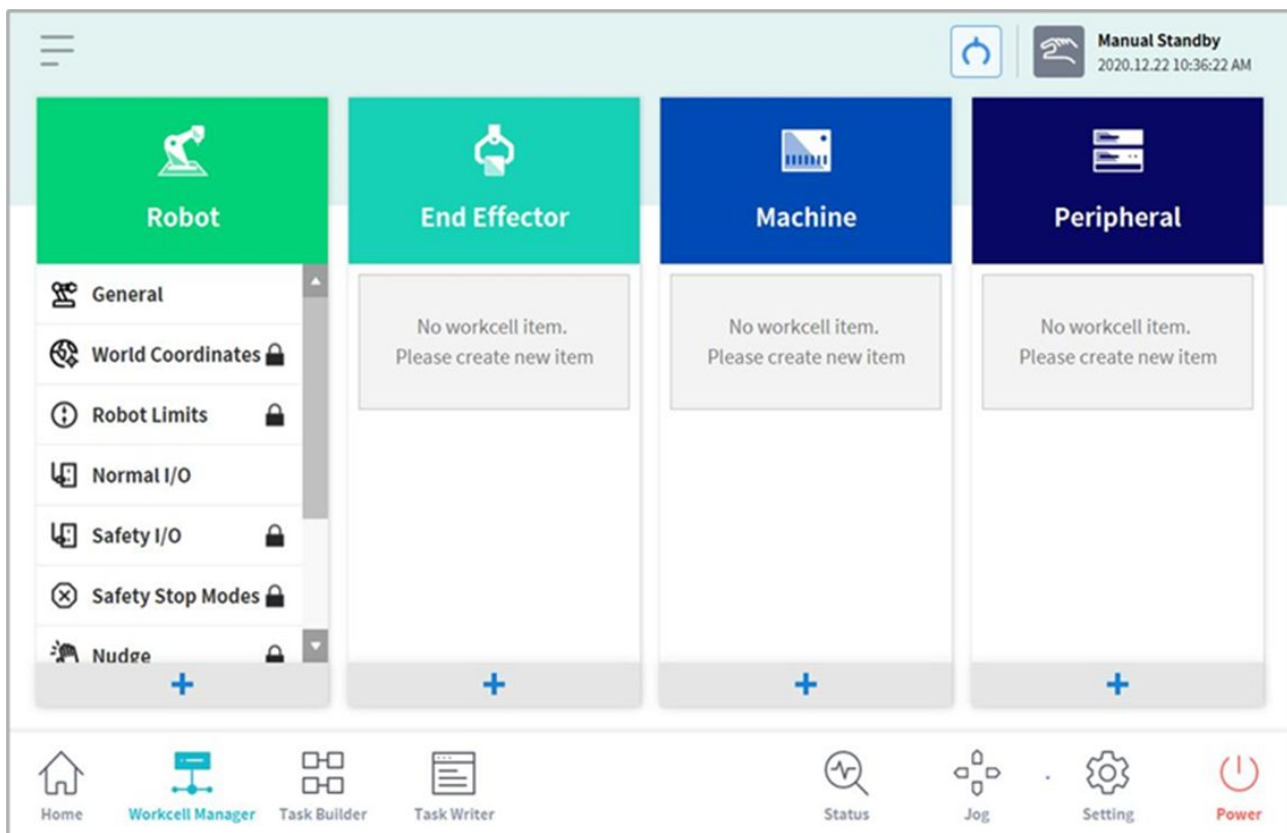

This displays the Workcell Item Package Version compatible with the current SW, Workcell Items that are not installed, and the name and type of Workcell Items that are not compatible. In order to properly use such Workcell Items, the corresponding Workcell Item must be downloaded from Doosan Mate and installed.

!
Not Available Workcell Item

Failed to configure Workcell Item information. Download Workcell Item Package from Robot Lab Website and install the item listed below.

Compatible Version Workcell Item Package 1.1 i

✕ **Not Installed**

Workcell Item Name	Workcell Item Type
Schmalz_ECBPI	SchmalzCobotPump
Schunk_Co-act_EGP-C	SchunkCoact

⊘ **Incorrect Version Compatibility**

Workcell Item Name	Workcell Item Type
g1	Robotiq_2f85
g2	Robotiq_2f85
g3	Robotiq_3f120

OK

4.7 Utilizing Workcell Manager

4.7.1 Robot Safety Setting

The following safety settings must be configured before operating the robot for the first time after installation.

⚠ **Warning**

Safety-related parameters must be determined through the comprehensive risk assessment, and safety parameter settings and the operation of safety functions must be verified before operating the robot.

Safety Limit Setting

For more information about the universally applied safety limit, refer to [Robot Limits Setting](#)(p. 273).





Space Limit and Zone Setting

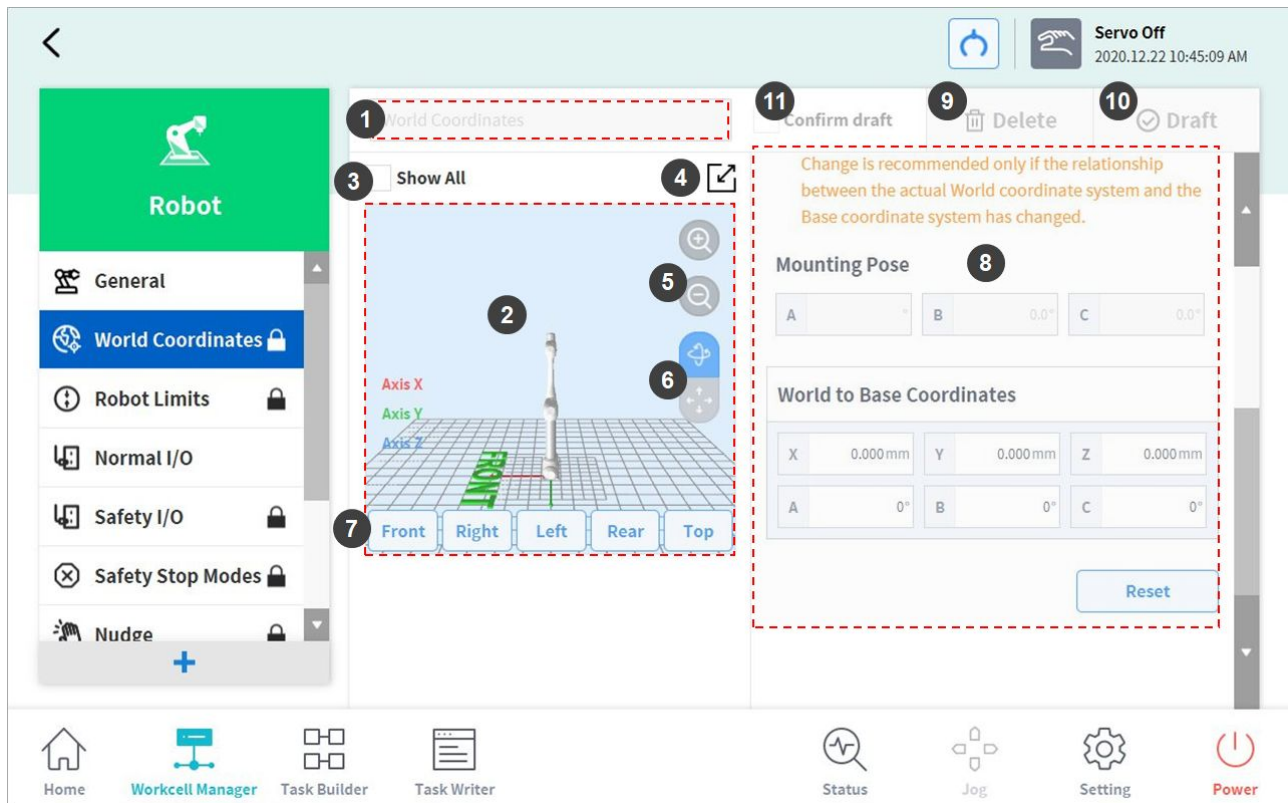

For more information about the spatial limit which limits the work space of the robot and the zone settings for configuring safety limits for each zone, refer to [Space Limit and Zone Settings Overview](#)(p. 262).

4.7.2 Robot Setting

The robot setting screen layout is composed as follows:



No.	Item	Description
1	Enter Workcell Name	Enter the name of the Workcell.
2	Simulation Screen	Displays the work space simulation of the Workcell.
3	View All	All other registered Workcells are displayed. Selecting all checkboxes enables the View All function. De-selecting checkboxes disables the function.
4	Change to Full Screen()	The simulation screen is displayed as a full screen. Tap the minimize button () on the full screen to return to the minimized screen.
5	Zoom In()// Zoom Out()	Zoom in or out the simulation screen.

No.	Item	Description
6	Rotate ()// Move ()	Rotate or move the simulation screen. Tap the button and drag or tap the screen to control.
7	Simulator Direction Setting	Sets the direction of the simulator. The simulation is displayed from the selected direction.
8	Workspace	Displays the workspace of the Workcell.
9	Delete	Deletes the current Workcell.
10	Draft Confirm	Draft: This temporarily saves the workspace settings of Workcell. Confirm: This saves the current or confirmed temporary save of the workspace settings of Workcell. (For safety-related Workcells only, the Confirm button is displayed after Confirm Temporary Save has been performed. For general Workcells, only the Confirm button is displayed.)
11	Confirm Draft	This confirms to save the temporarily saved workspace settings. (This is displayed only for safety-related Workcells and not displayed for general Workcells)

Tool Shape Setting

To set the robot tool shape, tap the  Add button on the **Robot** Workcell and select **Robot > Tool Shape**. The Safety Password is required during setup.

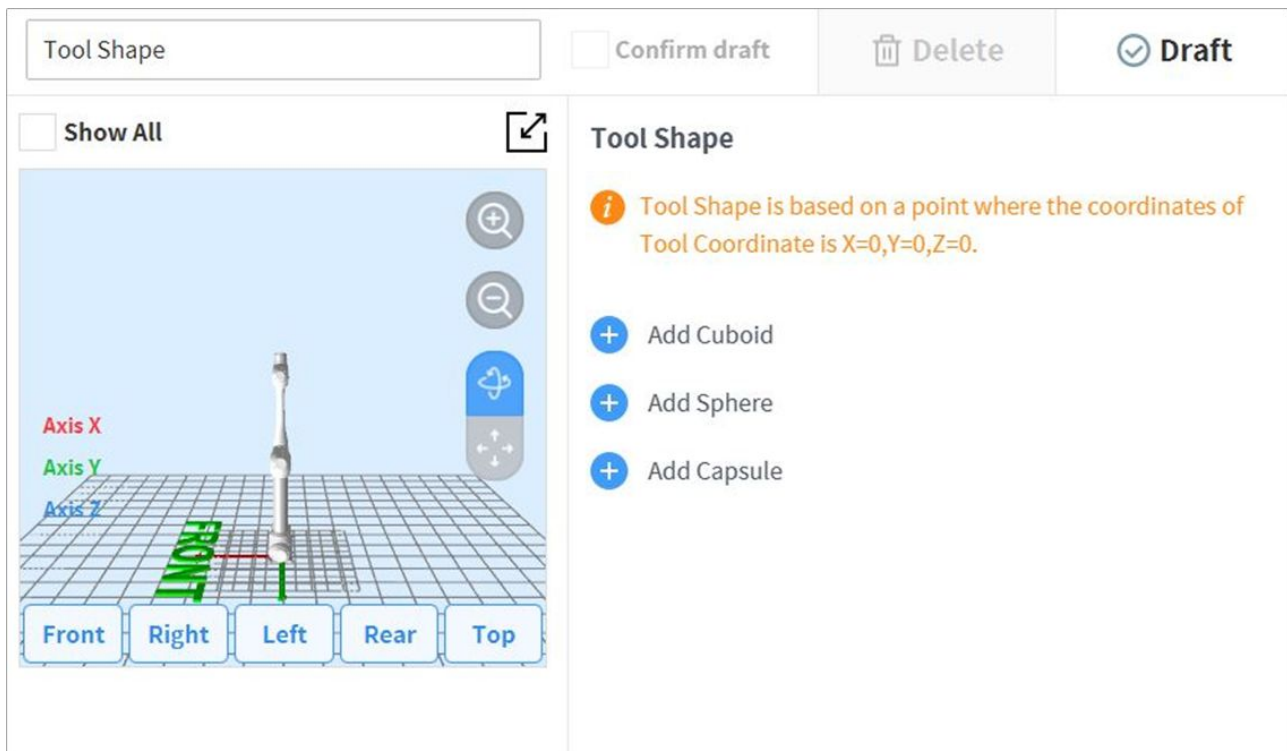

Tool shape can be set by adding Cuboid, Sphere, and Capsule shapes.

Select a shape that matches the tool and tap the Confirm button.

World Coordinates Setting

A coordinate system representing the robot and workpiece can be set. This coordinate system is called World Coordinates, and it is different from Base Coordinates, which are fixed to the base. It is possible to set the pose of Base Coordinates using World Coordinates, and World Coordinates can be selected when teaching and moving using the robot in Task Builder and Task Writer. To set World Coordinates, tap the  Add button on the **Robot** Workcell and select **Robot > World Coordinates**.

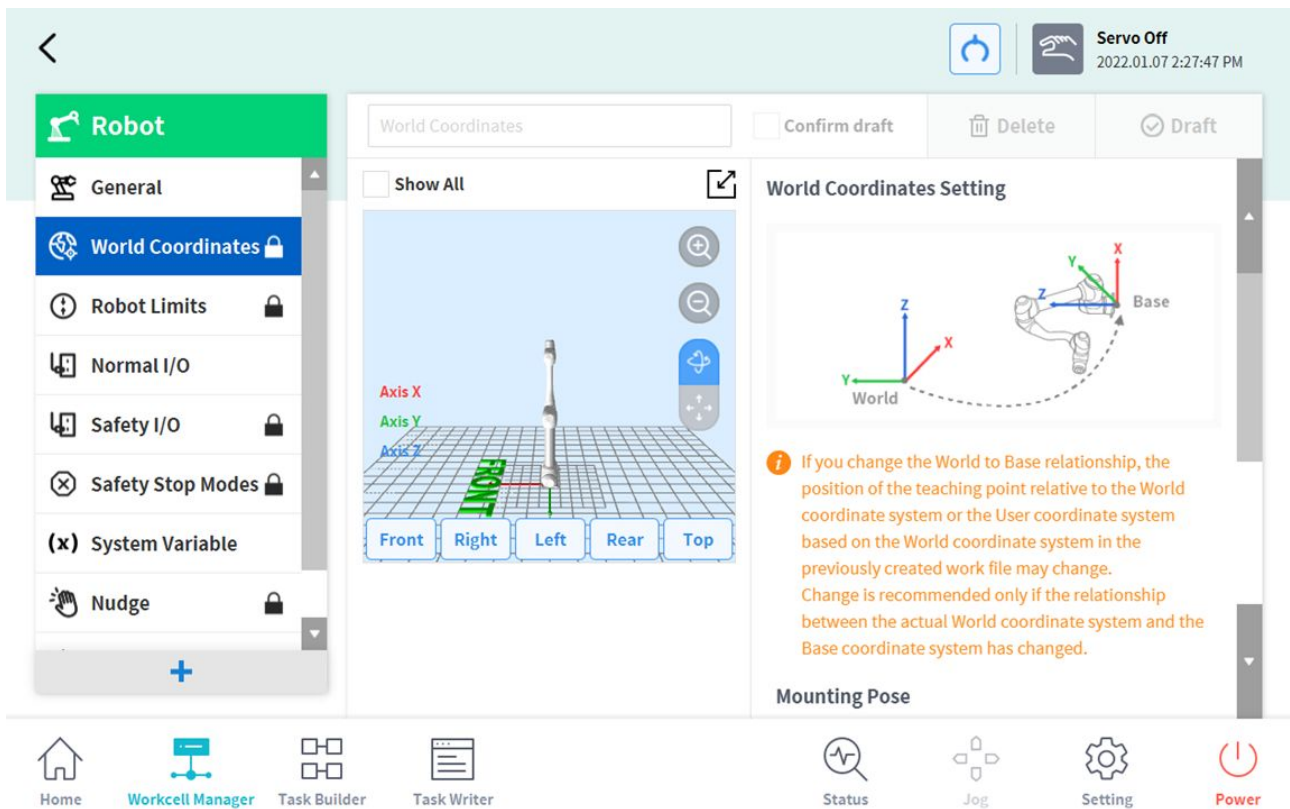

1. Tap the Edit button at the top.

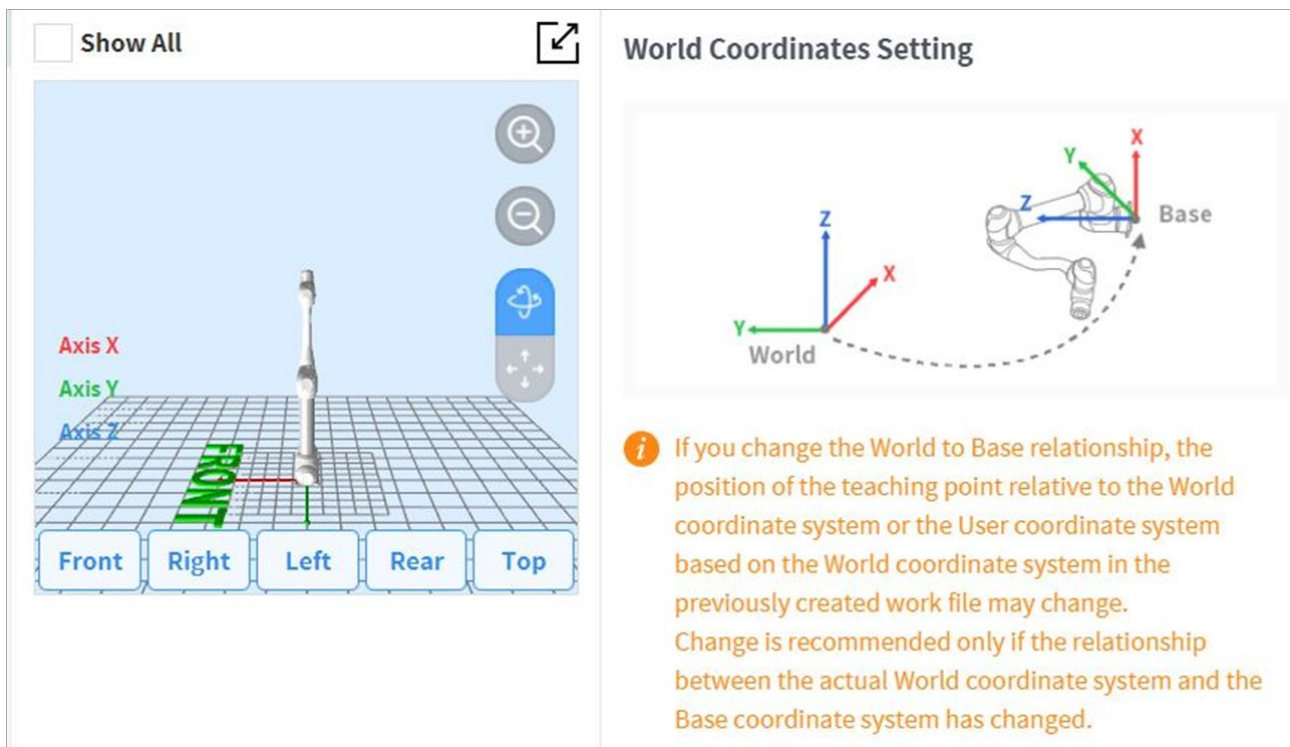

2. Please refer to the figure depicting the relationship between the World Coordinate and Base Coordinate, as well as related precautions.

Warning

When changing the relationship between World and Base coordinates, the teaching point of World Coordinates or user coordinates based on World Coordinates can change. Changes are only recommended when the actual relationship between World Coordinates and Base Coordinates are changed.

3. The mounting pose (installation inclination) is displayed on the right center. In general, World Coordinates describe the work environment from the user's perspective, so the Z-direction of World Coordinates is in the direction of the ceiling. Since one axis of Base Coordinates is fixed to the bottom plane of the robot, the relationship between World Coordinates and Base Coordinates changes according to the robot's installation location/pose. The above figure assumes that the robot is installed on a wall. In this case, the Z-axis of Base Coordinates is perpendicular to the wall, which is in parallel to the Y-axis of World Coordinates, and the mounting pose inclination and rotation are displayed as 90 and 0 degrees, respectively. The relationship between World and Base Coordinates is defined as the relationship of the Base Coordinates based on World Coordinates. If there is a predefined layout for the work environment, set the coordinates accordingly. The values X/Y/Z mean movement, and the values A/B/C mean rotation based on the definition of Euler Z-Y-Z. If the mounting pose is defined according to the robot's installation pose, it is appropriate to use the rotation angle of B/C as the mounting pose B/C. However, if the mounting pose is set using the Auto assumption function, the assumed value may contain a deviation, so it is recommended to use the rotation angle defined according to the layout.

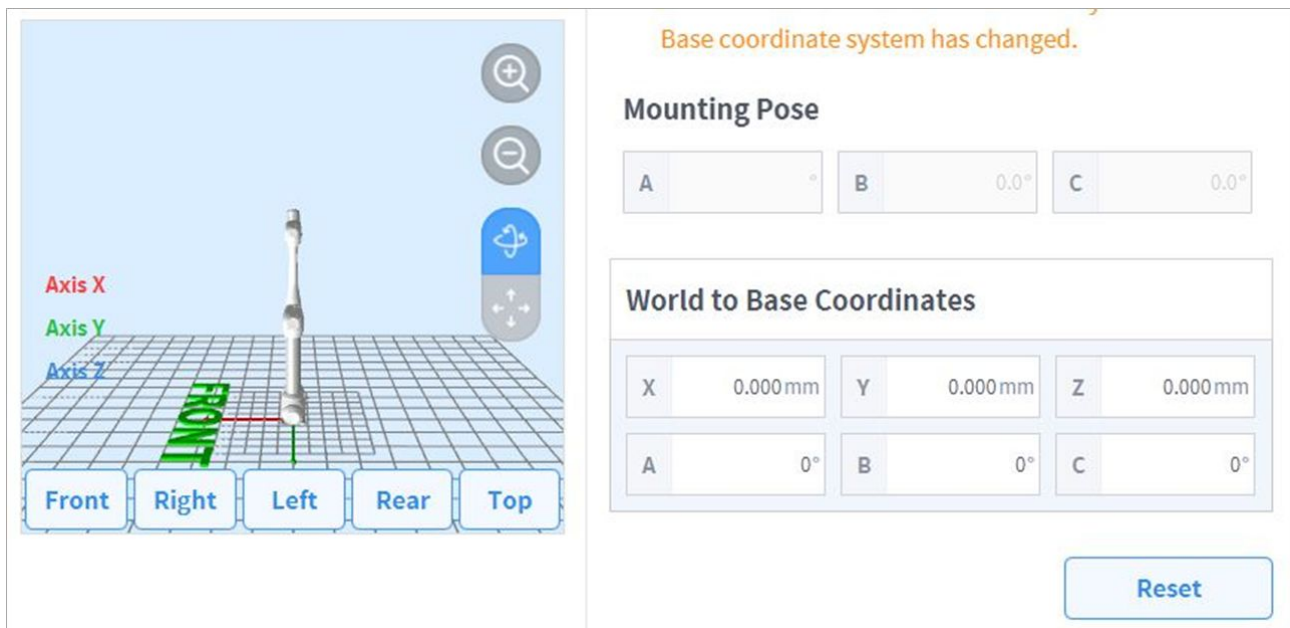

4. Tap the **Apply** button.

5. Tap the **Confirm** button.

Note

User programs created using Task Builder and Task Writer after applying the installation inclination in SW versions earlier than GF020400 must set World Coordinates with the installation inclination applied when updating to SW versions later than GF020400 and convert all Base Coordinates into World Coordinates within the user program in order to properly use existing teaching points.

If multiple robots are working in a common work space or if the robot is installed on a moving device such as a mobile base or linear track, the relationship and teaching point position between the workpiece and robot base may change. In such environments, World Coordinates, which are easy to teach work and share, can be set.

When a tool is installed or replaced, the weight of the tool must be configured before operating the robot. For more information about setting tool weight, refer to [Tool Weight Setting](#)(p. 276).

Normal I/O Setting

This function outputs various robot status signals through a single terminal. To set the Normal I/O, go to the **Robot** Workcell and select **Robot > Normal I/O**.

- **Single Output Setting**

Signal Name	Description
Safe Torque Off (L)	<ul style="list-style-type: none"> • High: Robot is not in Servo Off, Emergency Stop state • Low: Robot is in Servo Off or Emergency Stop state
Safe Operating Stop (L)	<ul style="list-style-type: none"> • High: Robot is not in Standby state • Low: Robot is in Standby state, and standstill monitoring is activated.
Normal Speed (L)	<ul style="list-style-type: none"> • High: Robot is operating at the reduced speed due to external Reduced Speed Activation safety input • Low: Robot is operating as normal speed
Reduced Speed (L)	<ul style="list-style-type: none"> • High: Robot is operating as normal speed • Low: Robot is operating at the reduced speed due to external Reduced Speed Activation safety input
Auto Mode (L)	<ul style="list-style-type: none"> • High: The robot is not in Auto Mode • Low: The robot is in Auto Mode
Manual Mode (L)	<ul style="list-style-type: none"> • High: The robot is not in Manual Mode • Low: The robot is in Manual Mode

Signal Name	Description
Remote Control Mode (L)	<ul style="list-style-type: none"> • High: The robot is not in Remote Control Mode • Low: The robot is in Remote Control Mode
Standalone Zone (L)	<ul style="list-style-type: none"> • High: The robot's TCP is in a Collaborative Zone • Low: The robot's TCP is not in any Collaborative Zone
Collaborative Zone (L)	<ul style="list-style-type: none"> • High: The robot's TCP is not in any Collaborative Zone • Low: The robot's TCP is in a Collaborative Zone
High Priority Zone (L)	<ul style="list-style-type: none"> • High: The robot's TCP is not in any Collision Sensitivity Reduction Zone and not in a High Priority Zone option checked Custom Zone • Low: The robot's TCP is in a Collision Sensitivity Reduction Zone or in a High Priority Zone option checked Custom Zone
Tool Orientation Limit Zone (L)	<ul style="list-style-type: none"> • High: The robot's TCP is not in any Tool Orientation Limit Zone • Low: The robot's TCP is in a Tool Orientation Limit Zone
Designated Zone (L)	<p>This is used to confirm if the TCP (Tool Center Point) is inside the user-defined Zone.</p> <p>The Designated Zone signal defined on the Safety Output setting UI can be selected from the Zone setting UI</p> <ul style="list-style-type: none"> • High: If the TCP is not inside any Zone linked with the Designated Zone normal output • Low: If the TCP is inside a Zone linked with the Designated Zone normal output
Task Operating (L)	<ul style="list-style-type: none"> • High: Task is not in operation • Low: Task is in operation
Robot In Motion (L)	<p>This is used to notify the operator that the robot joint is actually operating.</p> <ul style="list-style-type: none"> • High: The robot is stopped • Low: The robot is operating
Encoder Initialization Alarm (L)	<p>This is used to notify the operator that encoder initialization is required due to an issue in the home position setting.</p> <ul style="list-style-type: none"> • High: The robot does not require encoder initialization • Low: The robot requires encoder initialization
Home Position (L)	<p>This is used to confirm whether the robot is at the home position.</p> <ul style="list-style-type: none"> • High: The robot is not at the home position • Low: The robot is at the home position

Signal Name	Description
Deceleration - SS1 SS2 (L)	<p>This is used to check whether the robot is decelerating or not during operation. In standby or normal operation, the signal remains high. When deceleration starts, the signal changes to Low, and when deceleration ends, the signal returns to High again.</p> <ul style="list-style-type: none"> • High: Normal operation • Low: Deceleration by SS1 or SS2 is occurred

Safety I/O Setting

This function inputs/outputs safety-related signals through a redundant terminal. If a signal that is different from the redundant safety input or output signal is detected, the system determines whether it is a short circuit or hardware defect and stops the robot with STO Stop Mode.

- To set the Safety I/O, go to the **Robot** Workcell and select **Robot > Safety I/O**.

For more information, Refer to [Safety I/O](#)(p. 33).

Safety Stop Modes Setting

The safety-rated monitoring function can detect limit violations and set the Stop mode used when stopping the robot.

- To set the Safety Stop Modes, select **Workcell Manager > Robot > Safety Stop Modes**.

For more information, refer to [Safety Stop Modes](#)(p. 38).

Nudge Setting

If the robot stops in the collaborative zone due to safety stop mode SS2 or RS1,, reset is unavailable in Interrupted state but work can be resumed with nudge input

- To set Nudge, select **Robot > Nudge** item from the **Robot Workcell**.

For more information, refer to [Nudge](#)(p. 39).

User Coordinates Setting

The coordinate representing the workpiece can be set. This coordinate is called User Coordinates, and it is different from World Coordinates. It is possible to set the pose of User Coordinates using the base or World Coordinates, and User Coordinates can be selected when teaching and moving using the robot from Task Builder and Task Writer. To set User Coordinates, tap the  Add button on the **Robot** Workcell and select **Robot > User Coordinates**.

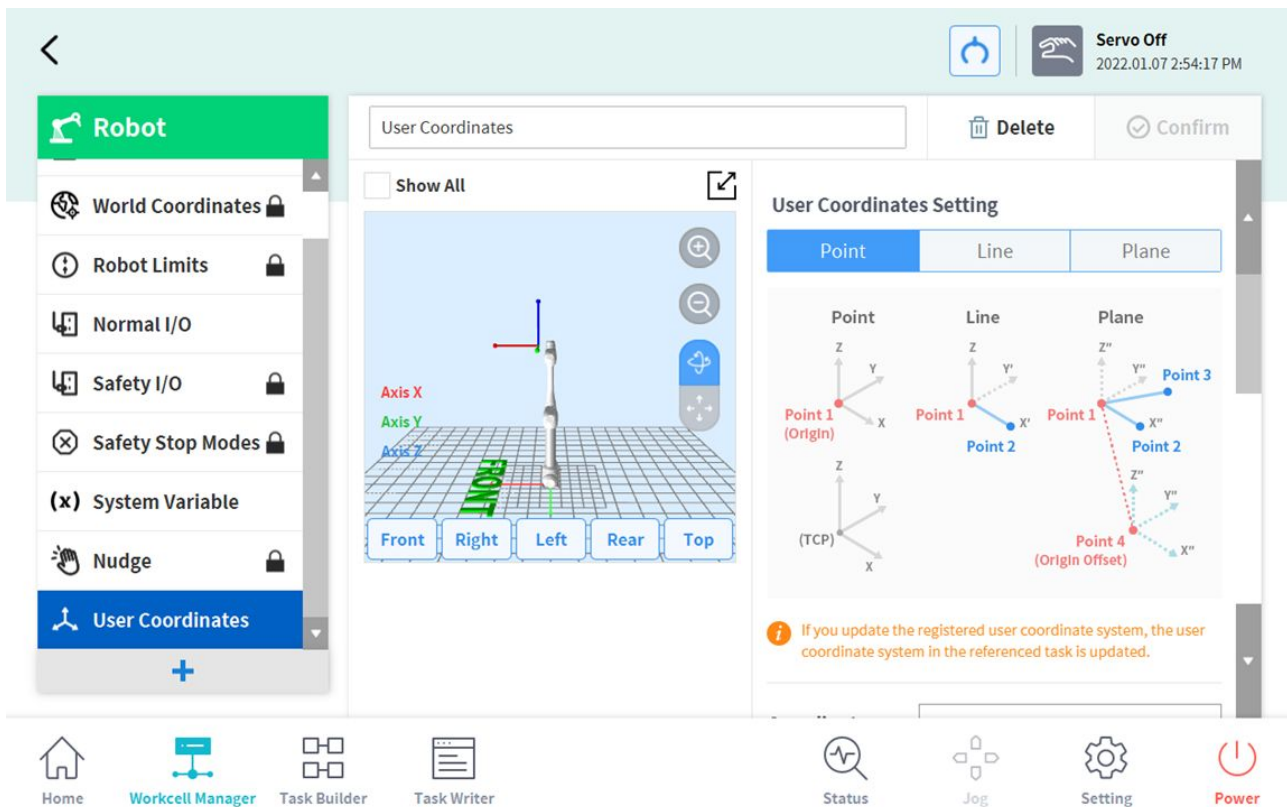

1. Enter the values required for settings.
2. Make sure to read the description image and cautionary items of the User Coordinates.
3. User Coordinates can be created based on 1-point, 2-points and 3-points.
4. It is possible to load pallet coordinates from Advanced Options and apply them to User Coordinates points.

System Variable Setting

It is a variable with variable, sequence and pose values saved in preset names/values.

- System variable name starts with the prefix 'System_'.
- Other than the Workcell Manager, system variables can be edited from the Task Builder and Task Writer screens.
- Preset user coordinates can be assigned to poses.

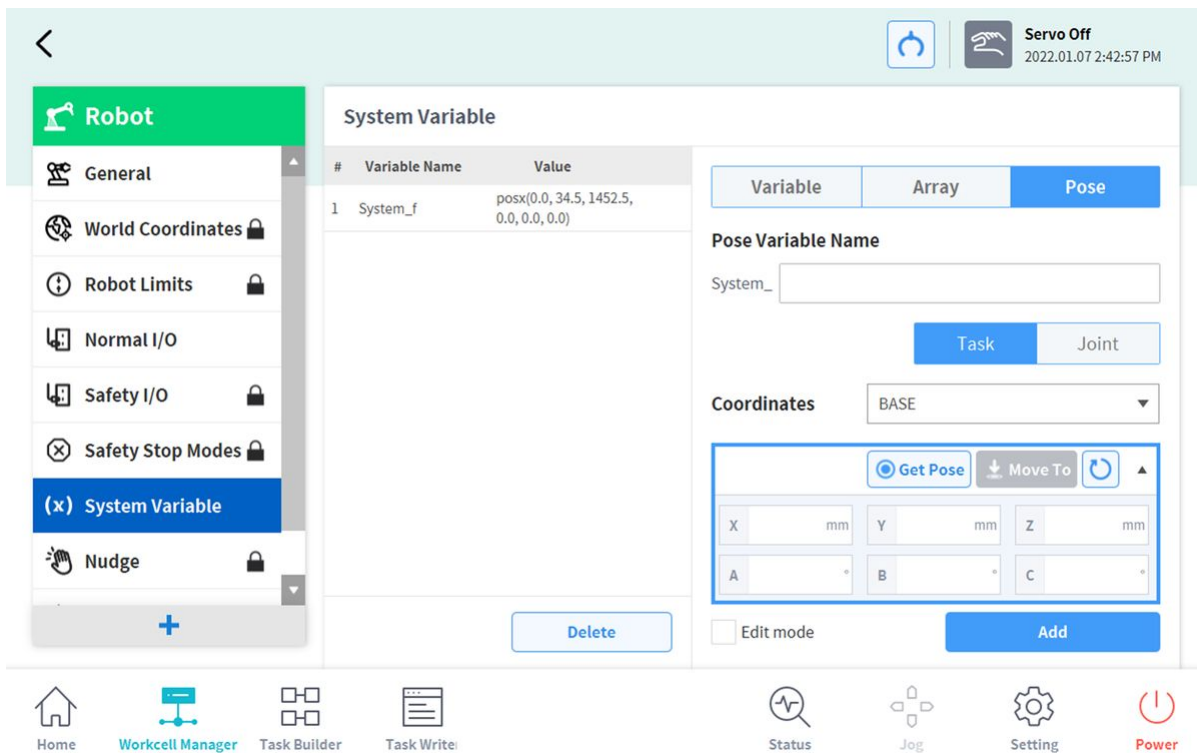

The following is the method of creating/editing/deleting/managing system variables.

- **Create:** Enter the variable name and value and click the Add button to create a system variable with the entered values.
- **Edit:** Click the edit mode checkbox to select system variables, edit the variable name and values, and click the Apply button to edit system variables.
- **Delete:** Select the system variables to delete from the system variable list and click the Delete button to delete system variables.
- **Manage:** For editing and management of system variables, refer to [Register and manage variables\(p. 157\)](#).

⚠ Caution

When restoring teach pendant data, data restoration will stop if the number of variables exceeds 50, the maximum number of additional items.

Space Limit and Zone Settings Overview

For more information on space limits and zones, see the following in [PART 1. Safety Manual\(p. 9\)](#).



- [Space Limit\(p. 40\)](#)
- [Zone\(p. 40\)](#)

Space Limit and Zone Shape

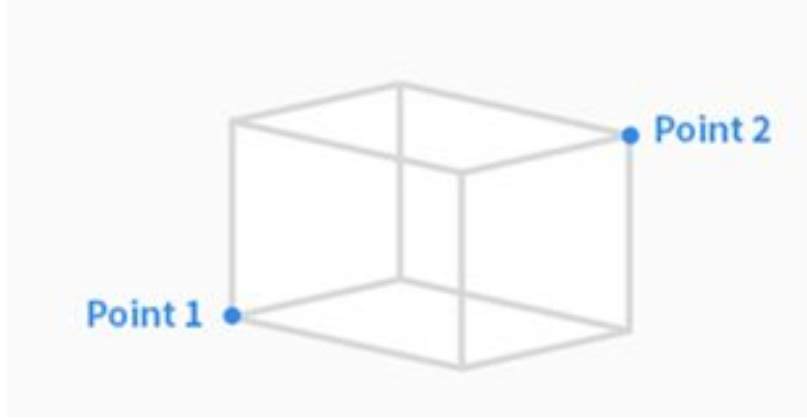
The shapes of **Space Limit / Zone** are set according to the following:

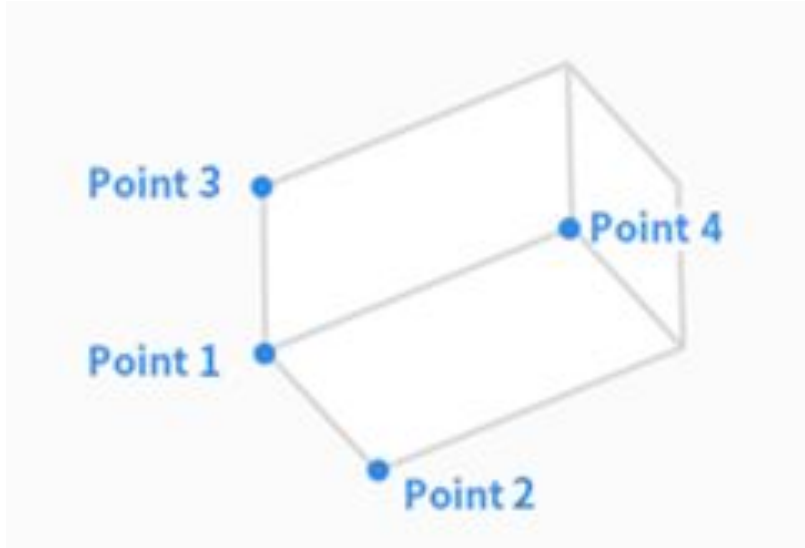
Item	Description
Cuboid	<p>The shape of Space Limit / Zone is set as a cuboid.</p> <ul style="list-style-type: none">• Enter the lower endpoint (Point 1) and upper endpoint (Point 2) of the cuboid and tap the Save Pose button.  <p>The diagram shows a 3D wireframe of a cuboid. Two blue dots mark specific vertices: 'Point 1' is located at the bottom-left-front corner, and 'Point 2' is located at the top-right-back corner. The cuboid is drawn with light gray lines on a light gray background.</p>

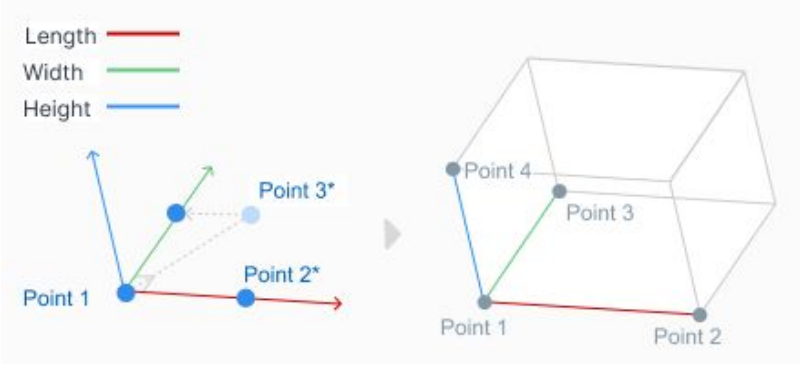
Item	Description
Tilted Cuboid	<p>The shape of Space Limit / Zone is set as a tilted cuboid.</p> <p>Setting by 4 Points</p> <ul style="list-style-type: none"> • Enter the reference point (Point 1), x-axis endpoint (Point 2), y-axis endpoint (Point 3), z-axis endpoint (Point 4) of the tilted cuboid and tap the Save Pose button. • The three lines (Point 1-Point2, Point 1-Point 3, Point 1-Point 4) must cross each other at right angles. (a deviation of +/- 5 degrees is acceptable) • Using the Constraint Motion of “Surface Lock” and “Axis Lock” based on Point 1 will help the robot obtain Point 2, Point 3 and Point 4 more easily.  <p>Setting by 3 Points and Height</p> <ul style="list-style-type: none"> • Enter the reference point (Point 1), the point on the x-axis (Point 2), and the point on the xy-plane (Point 3). • The location of the point on the xy-plane(Point 3) determines the direction of the y-axis, which is perpendicular to the line formed by the reference point (point 1) and the point on the x-axis (point 2) and located on the xy-plane. • Once the reference point, x-axis direction, and y-axis direction are determined, the z-axis direction is determined by the right-hand rule. • After the reference point and three axis directions are determined, the size of the tilted cuboid can be specified by setting the length, width, and height. • Tilted cuboid can be moved parallel (parallel translation) by setting the x, y, and z offset. • After reaching the endpoint(vertex) of the tilted cuboid by pressing “move to” beside Actual Point 1, then pressing the “move to” beside Actual Point 2, Actual Point 3, or Actual Point 4, Robot TCP will move it along the edge of the tilted cuboid as far as it can reach. The position and direction setting of the tilted cuboid can be verified this way.

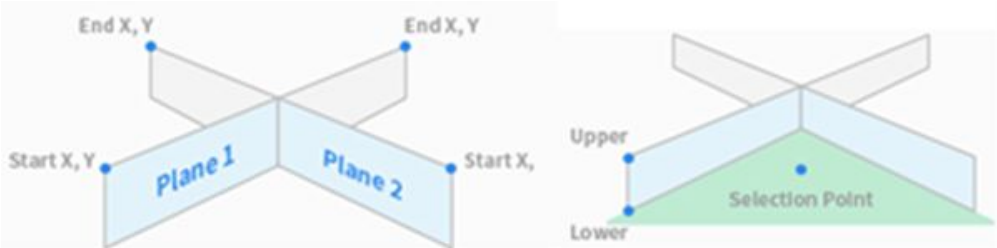
Item	Description
	
Cylinder	<p>The shape of Space Limit / Zone is set as a cylindrical.</p> <ul style="list-style-type: none"> Enter the point at a radius distance, the point of the upper plane and the point of the lower plane of the cylinder, and tap the Save Pose button. 
Multi-plane Box	<p>The shape of Space Limit / Zone is set as a multi-plane box.</p> <ul style="list-style-type: none"> Set the height of the top and bottom of the multi-plane box and press the Add Pose button to add a plane. Select X and Y coordinates to set the direction of the plane and tap the Save Pose button. Up to six planes can be configured. Set the coordinates for the points of the area to be configured. 

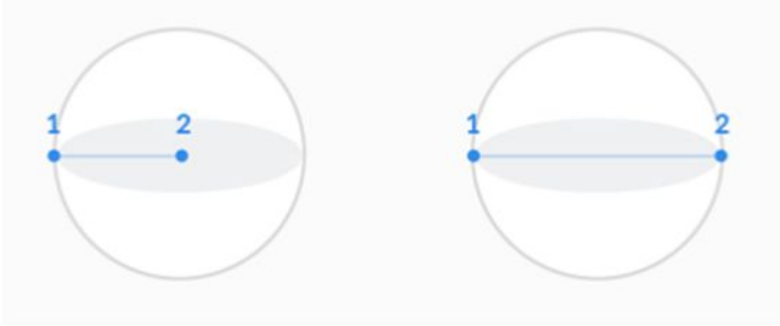
Item	Description
Sphere	<p>The shape of Space Limit / Zone is set as a sphere.</p> <ul style="list-style-type: none"> To configure the radius, enter the positions of the center point and endpoint of the sphere, and to configure the diameter, enter two endpoints of the sphere, then tap the Save Pose button. 

Space Limit Settings

To set space limits for the robot, tap the **+** Add button on the **Robot** Workcell and select **Space Limit>Cube, Cylinder, Multi-plane Box, Sphere or Tilted Cuboid**. The safety password is required during setup and activation.

1. Enter the Workcell Name in the Workcell Name field on the top of the Workcell Setting screen.
2. Set the pose information according to the **Space Limit** shape along with the **Inspection Point, Valid Space** and **Zone Margin** in the **Geometry** tab.
3. Set the Dynamic Zone Enable and Advanced Options in the Parameters tab, and press Draft.
4. Verify that all parameters displayed are the same as what are Intended to be set, then check **Confirm draft** and press **Confirm**
5. Press the Activate Toggle button to apply the **Space Limit**.

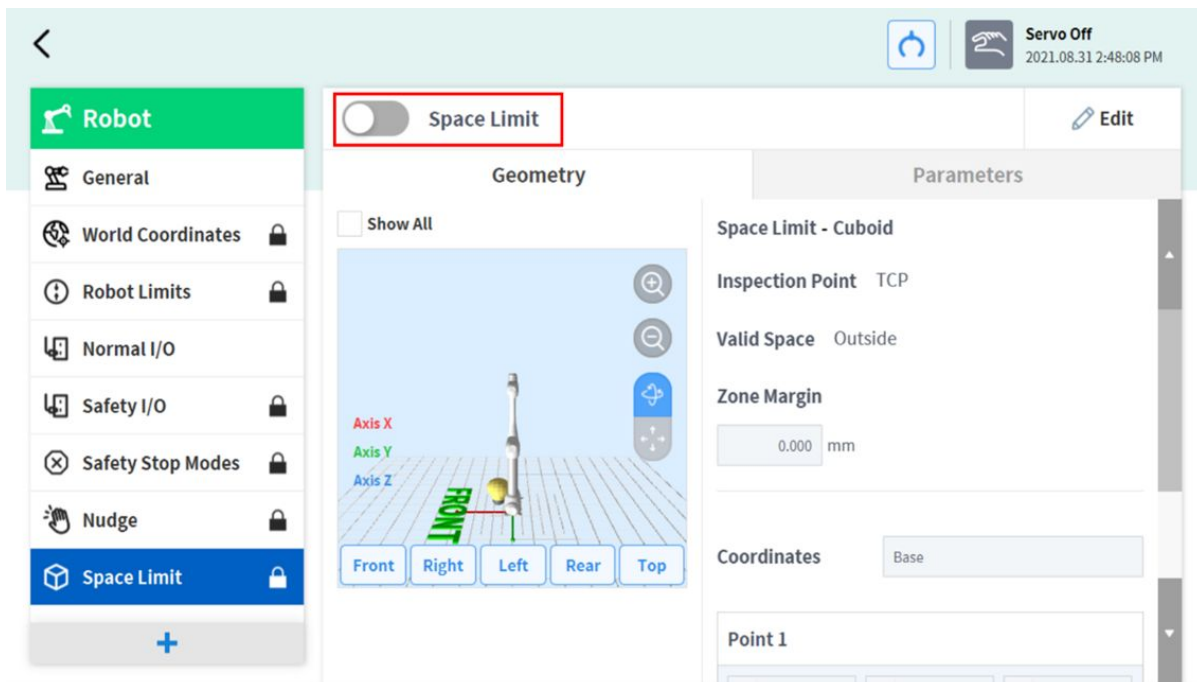

Note

There are **Zone Margin** defaults depending on the setting methods.

- If the tool shape is set and Body volume check is not selected, TCP margin is 0 mm.
- If the tool shape is set and Body volume check is selected, TCP margin is 0 mm.
- If the tool shape is not set and Body volume check is not selected, TCP margin is 0 mm.
- If the tool shape is not set and Body volume check is selected, TCP margin is 60 mm.

Collaborative Zone Settings

To set the Collaborative Zone, tap the **+** Add button on the **Robot** Workcell and select **Collaborative Zone > Cuboid, Cylinder, Multi-plane Box, Sphere or Tilted Cuboid**. The safety password is required during setup and enablement.

1. Enter the Workcell Name in the Workcell Name field on the top of the Workcell Setting screen.
2. Set the pose information according to the **Zone shape** along with the **Valid Space** and **Zone Margin** in the **Geometry** tab.
3. Set the TCP/Robot Limits, Safety Stop Modes and Dynamic Zone Enable in the Parameters tab, and press **Draft**.
4. Verify that all parameters displayed are the same as what are Intended to be set, then check **Confirm draft** and press **Confirm**
5. Press the Activate Toggle button to apply the **Collaborative Zone**.

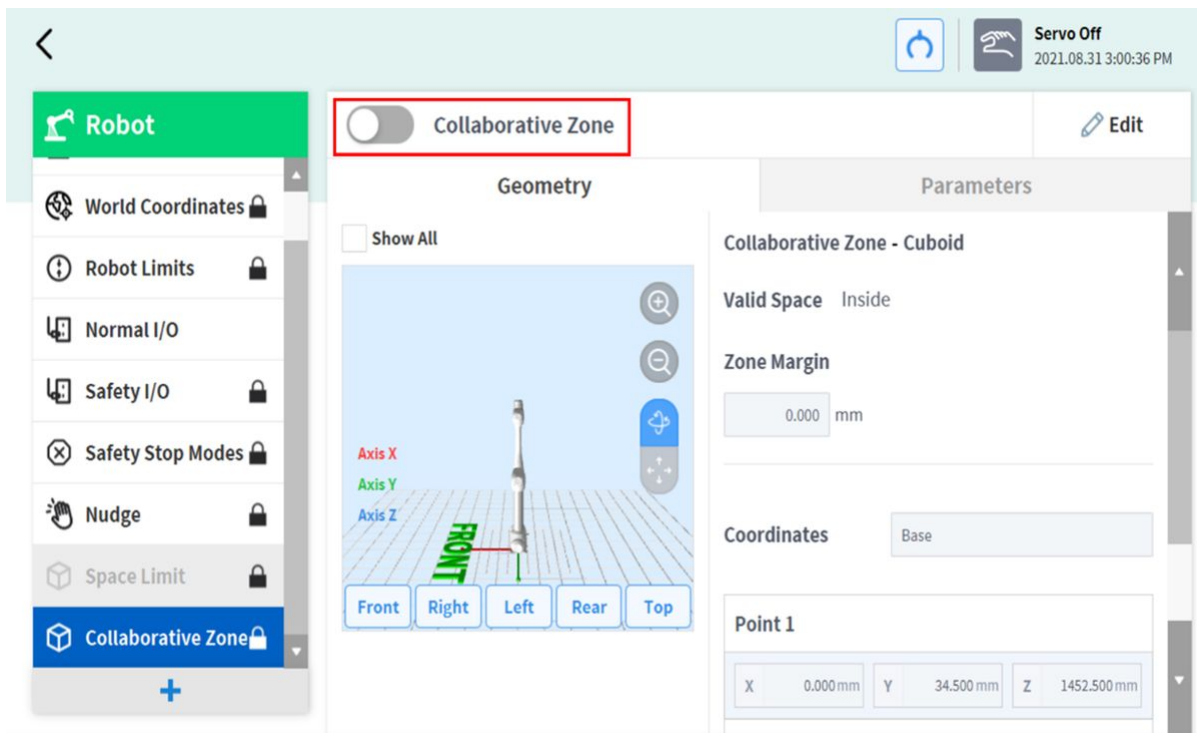

Crushing Prevention Zone Settings

To set the Crushing Prevention Zone, tap the **+** Add button on the **Robot** Workcell and select **Crushing Prevention Zone > Cuboid, Cylinder, Multi-plane Box, Sphere or Tilted Cuboid**. The safety password is required during setup and enablement.

1. Enter the Workcell Name in the Workcell Name field on the top of the Workcell Setting screen.
2. Set the pose information according to the Zone shape along with the **Valid Space** and **Zone Margin** in the **Geometry tab**.
3. Set the TCP/Robot Limits, Safety Stop Modes, Dynamic Zone Enable and Advanced Options in the Parameters tab, and press Draft.
4. Verify that all parameters displayed are the same as what are Intended to be set, then check **Confirm draft** and press **Confirm**
5. Press the Activate Toggle button to apply the **Crushing Prevention Zone**.

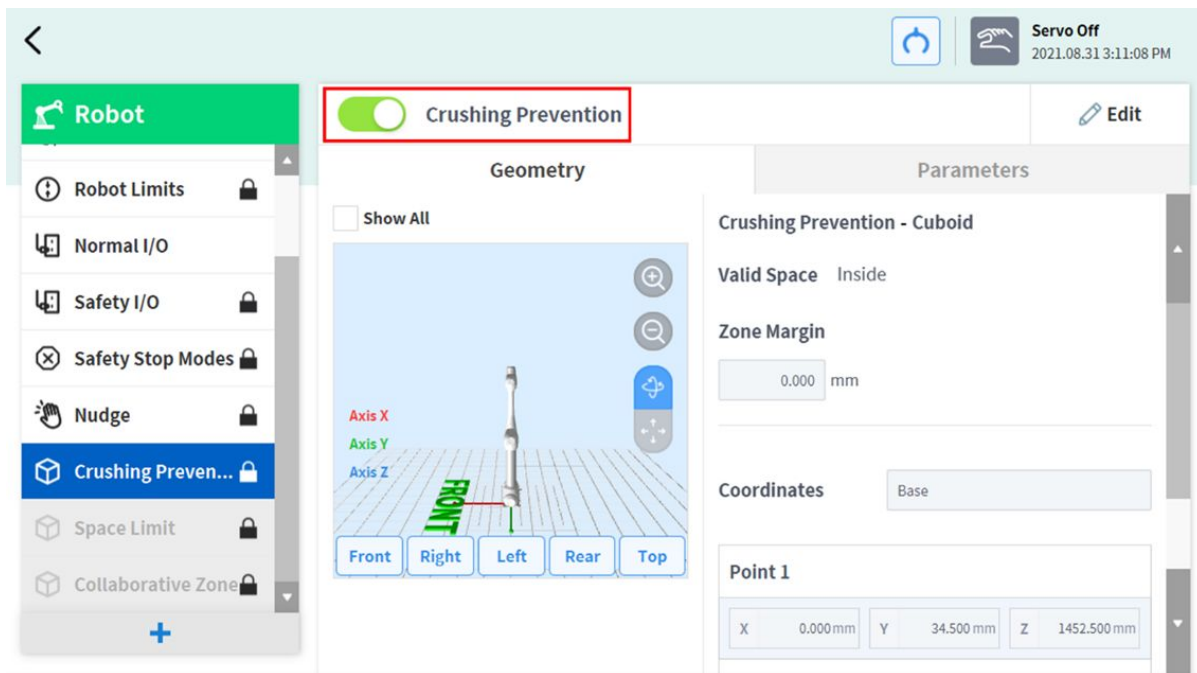

Collision Sensitivity Reduction Zone Settings

To set the Collision Sensitivity Reduction Zone, tap the **+** Add button on the **Robot** Workcell and select **Collision Sensitivity Reduction Zone > Cuboid, Cylinder, Multi-plane Box, Sphere or Tilted Cuboid**. The safety password is required during setup and enablement.

1. Enter the Workcell Name in the Workcell Name field on the top of the Workcell Setting screen.
2. Set the pose information according to the Zone shape along with the **Valid Space** and **Zone Margin** in the **Geometry** tab.
3. Set the override option, TCP/Robot Limits and Dynamic Zone Enable in the Parameters tab and press Draft.

Warning

- **Collision Sensitivity Reduction Zone** is a **High Priority Zone**.
- **High Priority Zones** have priority over the other Zones and global **Robot Limits** setting. And If multiple **High Priority Zones** are overlapped, the safety function uses the **LEAST** restricted safety limit. For these reasons, the size of **High Priority Zone** should be specified as small as possible for safety

4. Verify that all parameters displayed are the same as what are Intended to be set, then check **Confirm draft** and press **Confirm**
5. Press the Activate Toggle button to apply the **Collision Sensitivity Reduction Zone**.

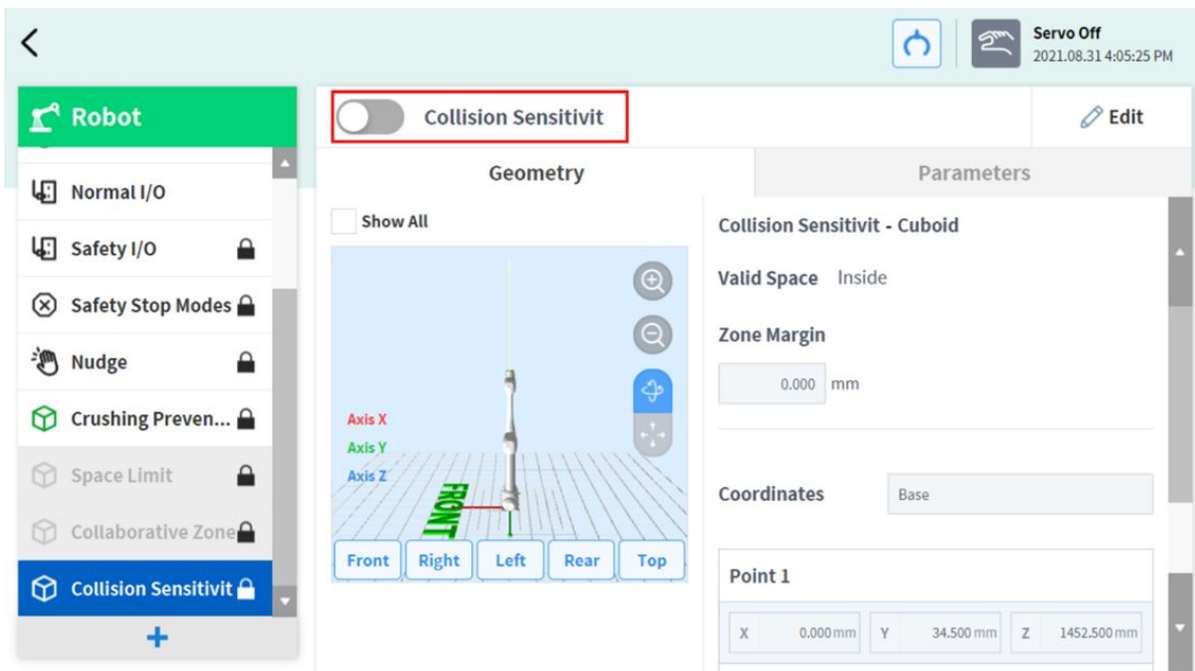

Tool Orientation Limit Zone Settings

To set the Tool Orientation Limit Zone, tap the **+** Add button on the **Robot** Workcell and select **Tool Orientation Limit Zone > Cuboid, Cylinder, Multi-plane Box, Sphere or Tilted Cuboid**. The safety password is required during setup and enablement

1. Enter the Workcell Name in the Workcell Name field on the top of the Workcell Setting screen.
2. Set the pose information according to the **Zone shape** along with the **Valid Space** and **Zone Margin** in the **Geometry tab**.
3. Set the TCP direction limit and Dynamic Zone Enable in the Parameters tab and press Draft.
4. Verify that all parameters displayed are the same as what are Intended to be set, then check **Confirm draft** and press **Confirm**
5. Press the Activate Toggle button to apply the **Tool Orientation Limit Zone**.

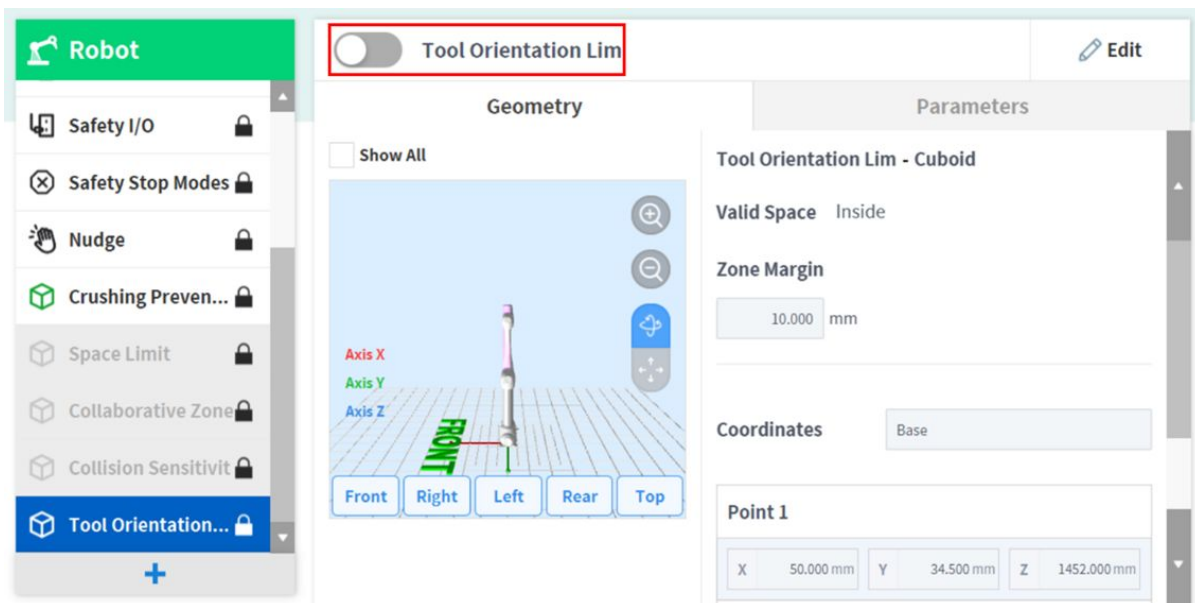

Custom Zone Settings

To set the **Custom Zone**, tap the **+** Add button on the **Robot** Workcell and select **Custom Zone > Cuboid**, **Cylinder**, **Multi-plane Box**, **Sphere**, or **Tilted Cuboid**. The **safety password** is required during setup and enablement.

1. Enter the Workcell Name in the Workcell Name field on the top of the Workcell Setting screen.
2. Set the pose information according to the Zone shape along with the **Valid Space** and **Zone Margin** in the **Geometry** tab.
3. To import shape setting configurations from another **Zone**, select the **Zone** from **Import Geometry & Parameters** in the **Advanced Options** and press **Import**.

Advanced Option ⌆

Import Geometry & Parameters

Select Workcell Item ▼

Import

4. Set the Priority Option, Override Option, TCP/Robot Limits, Safety Stop Modes, TCP direction limit, Joint Speed Limits, Joint Angle Limits, and Dynamic Zone Enable in the Parameters tab and press Draft.



Warning

High Priority Zones have priority over the other Zones and global **Robot Limits** setting. And If multiple **High Priority Zones** are overlapped, the safety function uses the **LEAST** restricted safety limit. For these reasons, the size of **High Priority Zone** should be specified as small as possible for safety.



Note

If the TCP is in a position where multiple **Zones** overlap, the following rules apply for each safety function individually.

1. Normal Mode

- If there is no zone set as **High Priority Zone**, the most restricted limit among the limits of overlapped **Zones** is selected as the safety limit for that position.
- If there is one **Zone** set as **High Priority Zone**, the limit of this Zone is selected as the safety limit for that position.
- If there are two or more **Zones** set as **High Priority Zone**, the **LEAST** restricted among the limits of overlapped Zones is selected as the safety limit for that position.

1. Reduced Mode

- If there is no zone set as a **High Priority Zone**, the most restricted limit among the limits of overlapped **Zones** is selected as the safety limit for that position.
- If there is one **Zone** set as a **High Priority Zone**, the safety limit for that position depends on **Override Option**.
 - If the **Override Option** is not checked, the most restricted limit between the limits of **High Priority Zone** and **Global Reduced Limit** is selected.
 - If the **Override Option** is checked, the limit of **High Priority Zone** is selected.
- If there are two or more **Zones** set as **High Priority Zone**, the safety limit for that position depends on **Override Option**.
 - If there is any **High Priority Zone** that **Override Option** is **NOT** checked, the most restricted limit among the **Global Reduced Limit** and the limits of **High Priority Zones** without **Override Option** is selected
 - If **Override Options** of all **High Priority Zones** are checked, the **LEAST** restricted limit among the the limits of **High Priority Zones** is selected

5. Verify that all parameters displayed are the same as what are Intended to be set, then check **Confirm draft** and press **Confirm**
6. Press the Activate Toggle button to apply the **Custom Zone**.

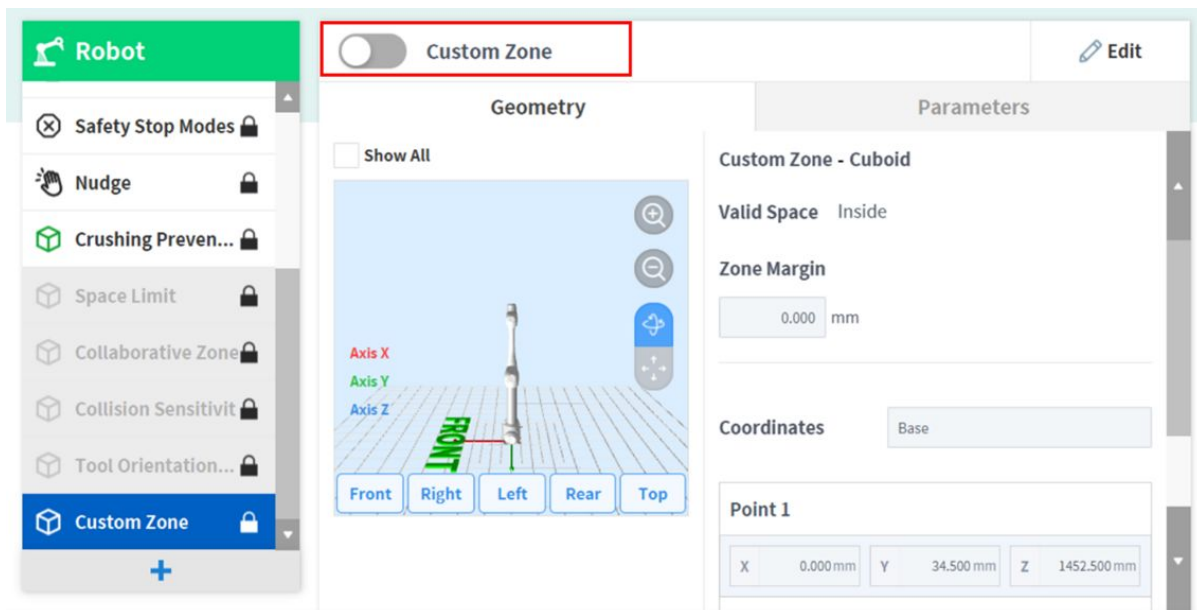

Robot Limits Setting

It sets the safety limits of safety monitoring functions.

Note

- The limit and initial safety settings may vary according to the robot lineup.
- Safety limits is the condition where the safety-rated monitoring function triggers the stop function. When stop is completed, the position of the robot and force applied externally may differ from the configured safety threshold.

TCP/Robot Limits

To set the TCP/Robot Limits, go to the **Robot** Workcell and select **Robot > Robot Limits > TCP/Robot**. The TCP/Robot Limits setting screen layout is composed as follows:

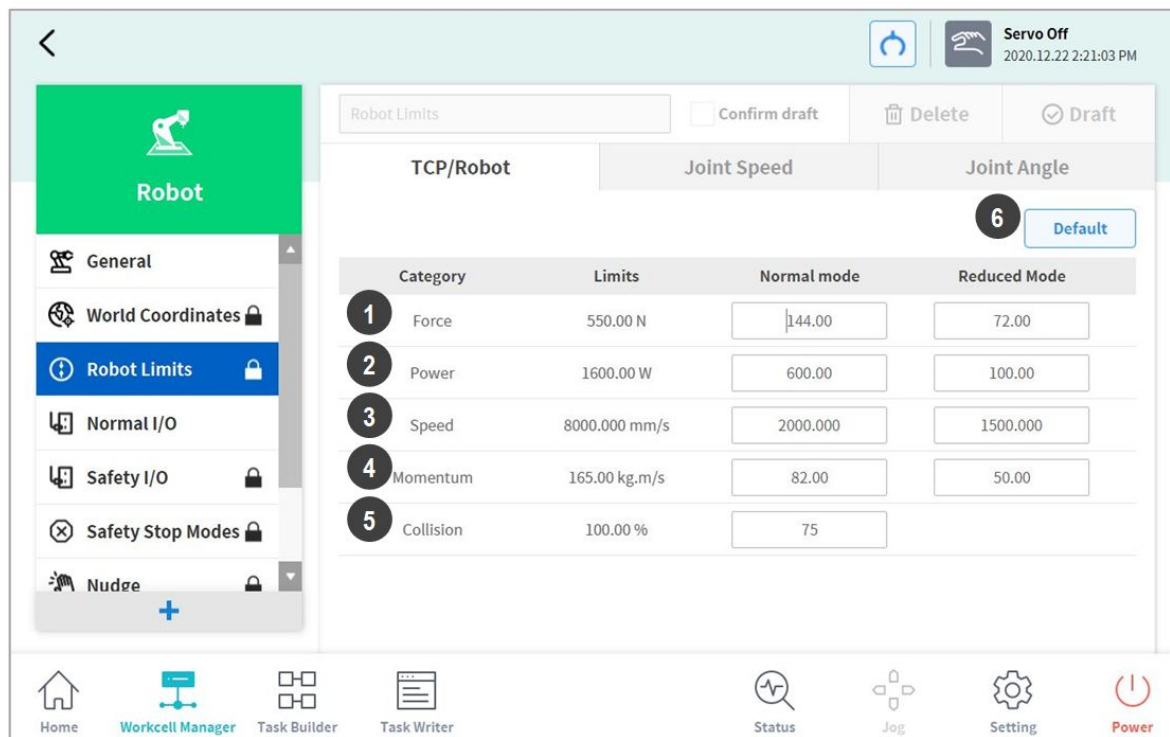

No.	Item	Description
1	Force (N)	It can limit the force level applied to the tool center point (TCP).
2	Power (W)	It can limit the mechanical power level of the robot.
3	Speed (mm/s)	It can limit the speed of the tool center point (TCP).
4	Momentum (kg.m/s)	It can limit the momentum size of the robot.
5	Collision (%)	It configures the collision detection sensitivity.
6	Default Value	It resets the TCP/Robot Limits settings to default values.

Joint Speed Limits

To set the joint speed limits, go to the **Robot** Workcell and select **Robot > Robot Limits > Joint Speed**. The Joint Speed Limits setting screen layout is composed as follows:

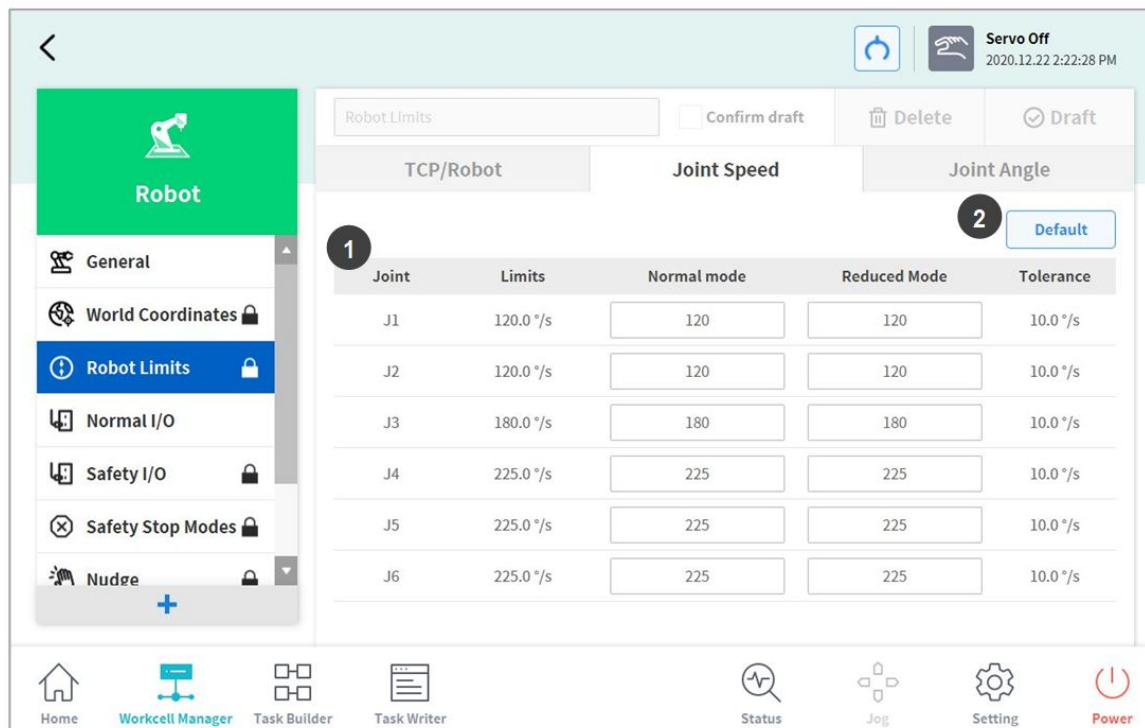

No.	Item	Description
1	Joint Speed	It can limit the speed of each joint. (J4 cannot be set for the P series.)
2	Default Value	It resets the Joint Speed Limits settings to default values.

Joint Angle Limits

To set the joint angle limits, go to the **Robot** Workcell and select **Robot > Robot Limits > Joint Angle**. The Joint Angle Limits setting screen layout is composed as follows:

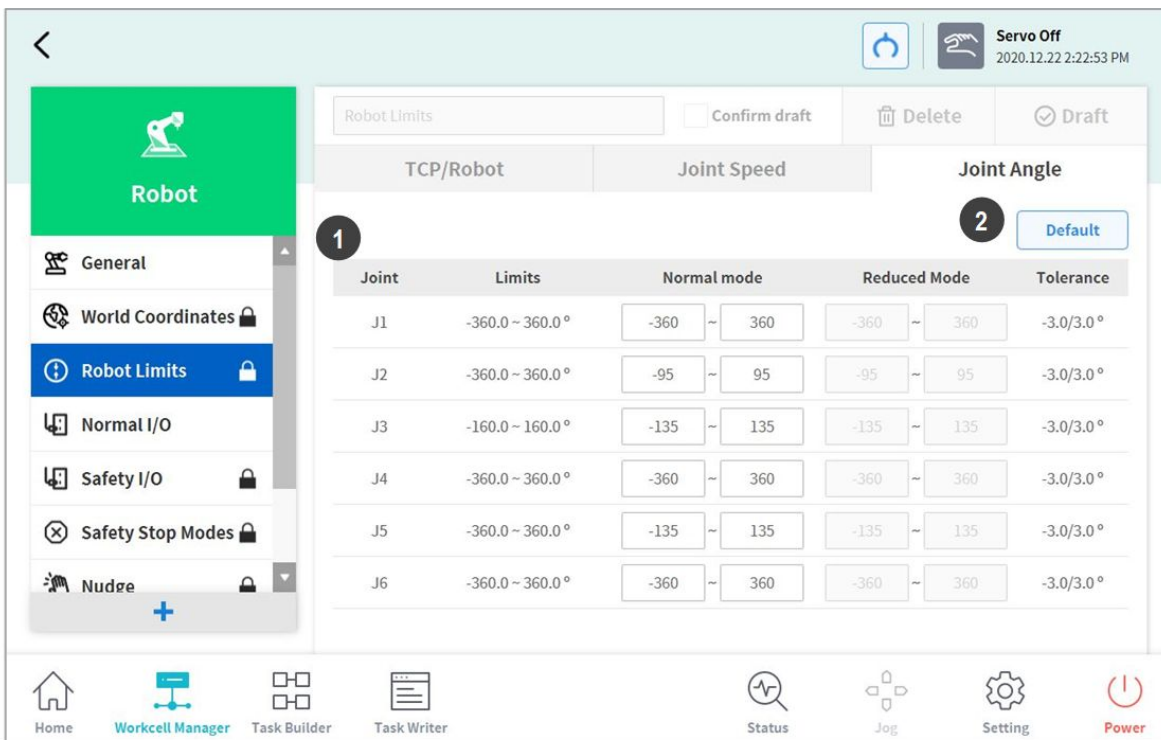

No.	Item	Description
1	Angle Range of each Joint	It can limit the angle range of each joint. (J4 cannot be set for the P series.)
2	Default Value	It resets the Joint Angle Limits settings to default values.

Tool Weight Setting

To configure the robot tool weight, tap the  "Add" button on the **Robot** Workcell and select **Robot > Tool Weight**.

Auto Tool Weight Measurement:

1. Select an Auto motion calculation method.
 - All Motion: All joints are used to measure tool weight.
 - **4, 5, 6 Motion:** Joints 4, 5 and 6 are used to measure tool weight.
2. Enable the checkbox of the parameter (weight, center of gravity) to estimate.
 - It is possible for the user to enter a known parameter value without enabling the checkbox.
 - If the user enters a known parameter, the values for parameters with their checkboxes enabled calculate the weight or center of gravity according to the entered parameter value.
3. Tap the **Auto Calculate**

Warning

- If the Auto Calculate checkbox for weight is disabled, enter a positive real number. (the center of gravity can be a negative real number or 0)
- Remove all obstacles before executing auto calculate.
- To execute Auto Calculate of 4, 5 and 6, the 3-axis angle must be greater than +30 degrees or less than -30 degrees.
- Note that safety monitoring functions are disabled during Auto Calculate.
- During Auto Calculate, the Auto Calculate button becomes the Stop button, which allows the user to stop Auto Calculate. If calculation is stopped, the weight and center of gravity values are reset.

Note

- When automatically measuring tool weight, there is a margin of error of ± 0.5 kg (1.1 lb).
- In case of the M series, when the maximum permissible tool weight is set, the automatic acceleration adjustment function is activated.

Mount Setting

The robot can be installed at any angle. To configure the robot installation pose, tap the **+** “Add” button on the **Robot** Workcell and select **Robot > Robot Installation Pose**. The robot installation pose can be entered manually or calculated automatically.

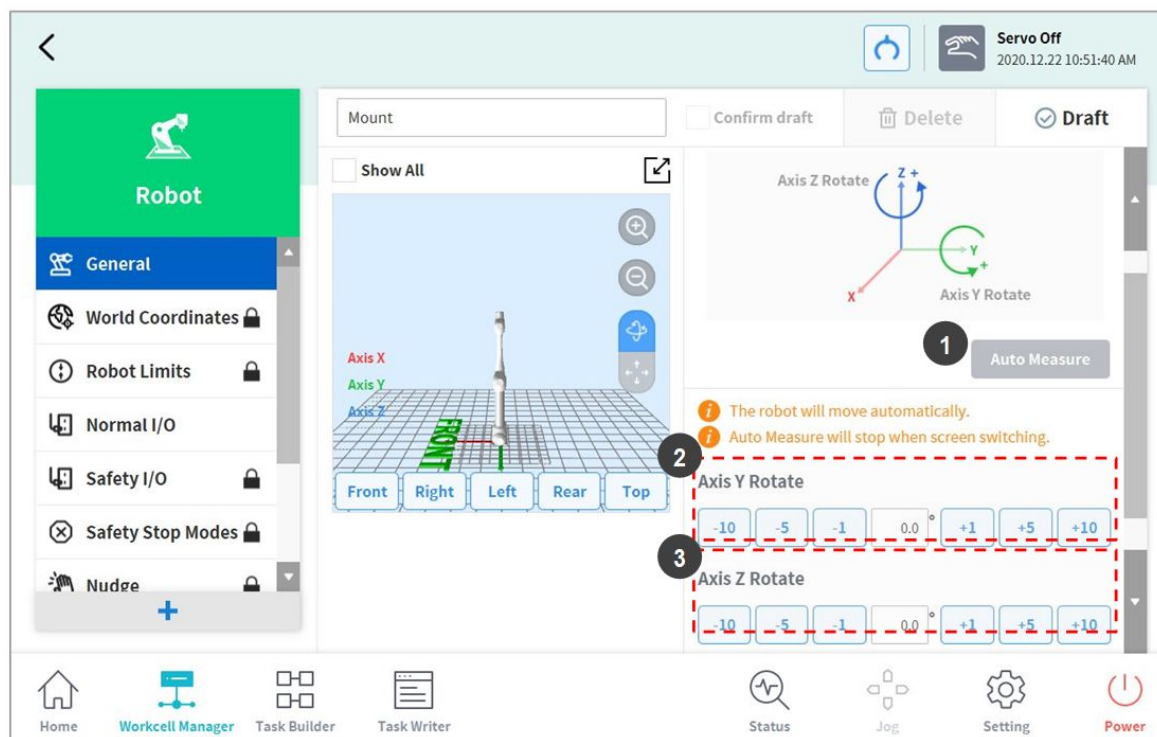

No.	Item	Description
1	Auto Calculate	Calculates the robot installation angle automatically.
2	Y-axis Rotation Setting	Enter the Y-axis angle of the robot during installation.
3	Z-axis Rotation Setting	Enter the Z-axis angle of the robot during installation.

Note

Tap the **Auto Calculate** button to calculate the inclination value automatically. The installation pose Auto Calculate function can be used when the robot base is inclined from the ground by more than 5 degrees. The Auto Calculate function for robot installation pose allows easy configuration of the installation pose required by direct teaching, force control and compliance control functions without entering accurate installation angle values, but the absolute position accuracy of the automatically calculated robot pose setting may be lower than that of accurately measured values.

Caution

- The H, P Series models do not support robot installation pose functions. Installation must be done on the ground.
- Auto Calculate is not supported in models without Force Torque Sensors.

4.7.3 End Effector Setting

The end effector is a device that acts directly on the target using the tool attached to its tool flange to execute the task the user has configured for the robot, and it has grippers (double-/single-action pneumatic grippers) and tools (tools and screwdrivers). In addition, user-built tools and screens can be added as Workcell Items. Doosan Robotics provide a web-based App Builder development eco system for Workcell Item app development. Manuals and web services for App Builder can be found at the Developer LAB.

- [Developer LAB] <https://devlab.doosanrobotics.com>⁷

Grippers and Tools

Grippers are end effectors that have fingers to pick up or drop objects. The following is the setting screen for a pneumatic gripper. This example will be used as the basis for explaining how to configure an end effector. For more information about each gripper setting, refer to the separate manuals provided.

The screenshot displays the configuration screen for the 'GripperDA_v1' end effector. The interface includes a sidebar with 'End Effector' and 'GripperDA_v1' options. The main area is divided into 'Interface' and 'Tool Center Point' tabs. Under the 'Interface' tab, the communication type is set to 'digital I/O' and the workcell item action is 'Grasp'. A table lists the I/O signals for grasping and releasing, with their respective I/O types and port numbers. The 'Grasp' and 'Release' actions are currently set to 'No Signal'.

Write/Read Signal Name	I/O Type	Port No.	Write/Read Signal
out_Grasp	Flange Digital Out	1	On / Off
out_Release	Flange Digital Out	2	On / Off
Grasp_in	Flange Digital In	1	No Signal
Release_in	Flange Digital In	2	No Signal

7. <https://devlab.doosanrobotics.com/>

1	Workcell Name Input Field	Enter the name of the end effector.
2	Communication	Sets the I/O signal of the end effector.
3	Tool Center Point	Sets the tool center point (TCP) of the end effector.
4	Output Signal	Checks and sets the output signal. (If a function is enabled in Workcell Item Action, its name and signal type are disabled.) <ul style="list-style-type: none"> • Name: Displays the output signal name. • Signal Type: Sets the output signal type (controller, flange). • Port Number: Select the end effector output signal port. • Signal: Tests the output signal status.
5	Input Signal	Checks and sets the input signal. (If a function is enabled in Workcell Item Action, its name and signal type are disabled.) <ul style="list-style-type: none"> • Name: Displays the output signal name. • Signal Type: Sets the input signal type (controller, flange, Modbus). • Port Number: Select the end effector output signal port. • Operation: Displays the input signal status. If the signal is normal, it is displayed as green.
6	Delete	Deletes the end effector being configured.
7	Confirm	Saves the setting.

Tool and screwdriver are available. Configuring tool settings is similar to that of gripper settings. For more information about each tool setting, refer to the reference manuals provided.

End Effector I/O Signal Setting

1. Tap the Add (+) Workcell button at the bottom of the end effector of the Workcell Manager.
2. Enter the Workcell name in the Workcell Name field at the top of the Workcell Setting screen.



The screenshot shows a horizontal bar with three elements: a text input field containing 'GripperDA_v1', a 'Delete' button with a trash icon, and a 'Confirm' button with a checkmark icon.

3. Select the port number for I/O signal setting. Default Value displays the initial value set by the App Builder.

Interface

Tool Center Position

Communication Type - digital I/O

Workcell Item Action Grasp Test

	Write/Read Signal Name	I/O Type	Port No.	Write/Read Signal
-	<input type="text" value="out_Grasp"/>	Flange Digital Out ▼	1 ▼	On Off
-	<input type="text" value="out_Release"/>	Flange Digital Out ▼	2 ▼	On Off
-	<input type="text" value="Grasp_in"/>	Flange Digital In ▼	1 ▼	● Checked
-	<input type="text" value="Release_in"/>	Flange Digital In ▼	2 ▼	● No Signal

+ Add Write Signal
 + Add Read Signal

4. Tap the Confirm button.

End Effector I/O Testing

To test the operation status of the connected end effector, follow the procedure below.

1. Select the end effector to test and tap the **Edit** button.

GripperDA_v1

✎ Edit

2. Tap the **On/Off** button of the **Signal** to test the output signal.

	Write/Read Signal Name	I/O Type	Port No.	Write/Read Signal
-	<input type="text" value="out_Grasp"/>	Flange Digital Out ▼	1 ▼	On Off
-	<input type="text" value="out_Release"/>	Flange Digital Out ▼	2 ▼	On Off

3. Select a function among the Workcell Item Actions and tap the Test button to test the end effector function.

Communication Type - digital I/O

Workcell Item Action Grasp Test

4. Check whether the end effector receiving the output signal operates normally.

Note

If the input signal is entered properly, a green indicator lights up.

Tool Center Point (TCP) Setting

When configuring the tool center point (TCP), the position and rotation angle based on the flange coordinates must also be defined. The distance from the default starting point of the flange coordinate to the tool center point (TCP) in the X, Y and Z directions cannot be set to be greater than 10000 mm. In addition, if the converted lengths ($L = \sqrt{X^2 + Y^2 + Z^2}$) of X, Y and Z are less than 300mm, direct teaching-point lock functions can be executed, and if the converted lengths are less than 500mm, force control and compliance control functions can be executed.

Warning

When TCP offset is set to 300mm or more, force control and compliance control performance may be reduced or vibration may occur depending on the work environment. Please use with caution.

In particular, if the TCP is configured using **Auto Calculate**, the calculation is made based only on the X, Y and Z positions, so it is necessary to enter the rotation angle. The rotation angle can be defined with items A, B and C, and it is based on the Euler Z-Y-Z rotation method.

The screenshot shows the software interface for GripperDA_v1. At the top, there is a text input field containing 'GripperDA_v1', a 'Delete' button, and a 'Confirm' button. Below this is a tabbed interface with two tabs: 'Interface' and 'Tool Center Point'. The 'Tool Center Point' tab is active and contains the following elements:

- Offset** section with an information icon:
 - X: 0.000mm
 - Y: 0.000mm
 - Z: 0.000mm
 - A: 0.0°
 - B: 0.0°
 - C: 0.0°
 A red dashed box highlights the A, B, and C rotation angle input fields.
- Auto Calculation** section with an information icon and a toggle switch (currently off):
 - Reference Pose (selected)
- A table with four rows:

Point	Get Pose	Move To Pose	Reset
Point 1	<input type="radio"/>	<input type="radio"/>	<input type="radio"/>
Point 2	<input type="radio"/>	<input type="radio"/>	<input type="radio"/>
Point 3	<input type="radio"/>	<input type="radio"/>	<input type="radio"/>
Point 4	<input type="radio"/>	<input type="radio"/>	<input type="radio"/>
- An **Auto Calculation** button at the bottom.

The definitions of the coordinate axis expressed with x, y, z and coordinate axis expressed with X, Y, Z are as follows:

- Coordinate axis of “Flange Coordinate” (x, y, z): The coordinate axis direction defined at the end of the flange is identical to the robot coordinate with a robot joint angle of $(0,0,0,0,0,0)$.
- Coordinate axis of “TCP Coordinate” (X, Y, Z): The coordinate axis is defined at the end of the tool installed on the end of the flange or working point. The rotation angle of the “TCP Coordinate” is defined based on the “Flange Coordinate” in the order of 1) to 3) of the following:

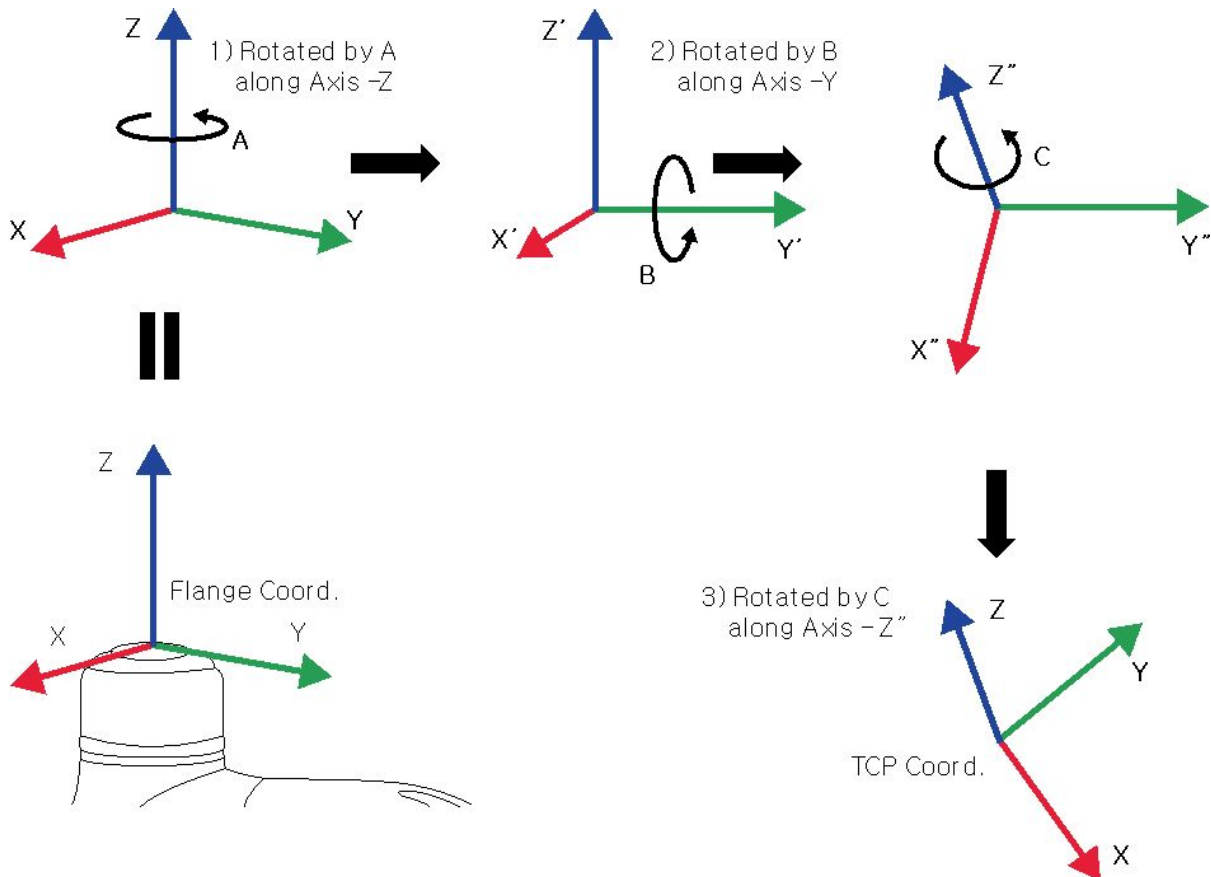

- 1) Rotate A degrees along the z axis of the Flange Coordinate
- 2) Rotate B degrees along the y' axis of the coordinate rotated according to 1)
- 3) Rotate C degrees along the z'' axis of the coordinate rotated according to 2)

Here are a few examples of configuring the TCP according to the method described above:

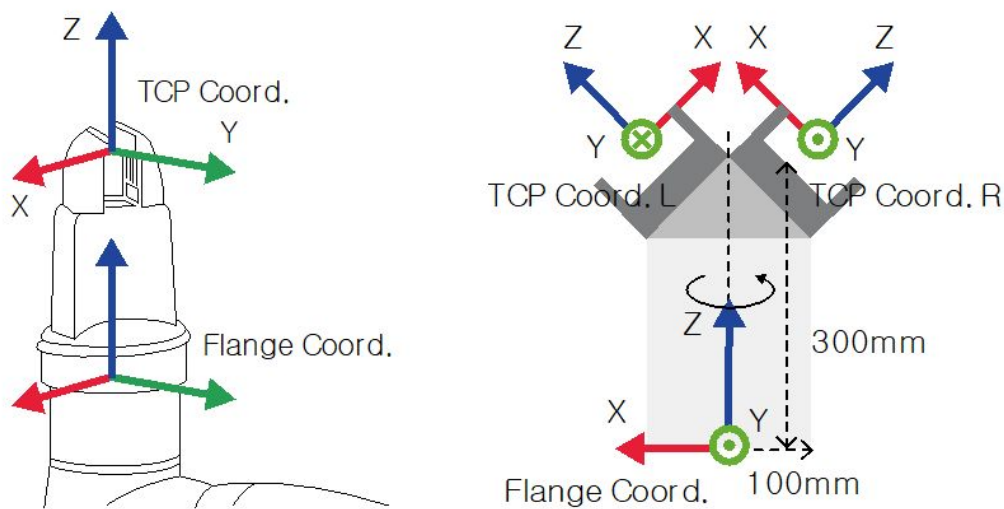

- $[X, Y, Z, A, B, C] = [0, 0, 100, 0, 0, 0]$: General Gripper with Z-direction offset (TCP Coord)
- $[X, Y, Z, A, B, C] = [100, 0, 300, 180, -45, 0]$: Left Gripper with 45-degree angle (TCP Coord. L)
- $[X, Y, Z, A, B, C] = [-100, 0, 300, 0, -45, 0]$: Right Gripper with 45-degree angle (TCP Coord. R)

Tool Center Point Setting based on Other End Effectors

When using a symmetrical double gripper, the TCP of an end effector is configured based on the other well-configured end effector. The TCP offset of a new end effector can be easily configured by rotating the pose and point on the tool coordinate at the base end effector TCP point on the Z axis by the angle entered.

1. Select the **Tool Center Point** tab on the end effector setting screen.

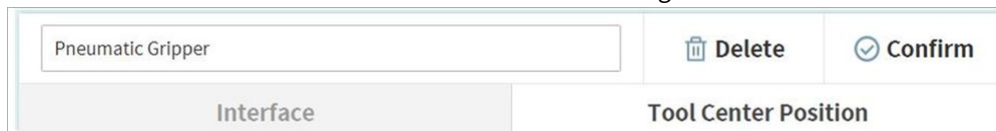

2. Tap the **Auto Calculate** toggle switch.



3. Select the **Reference End Effector** item.

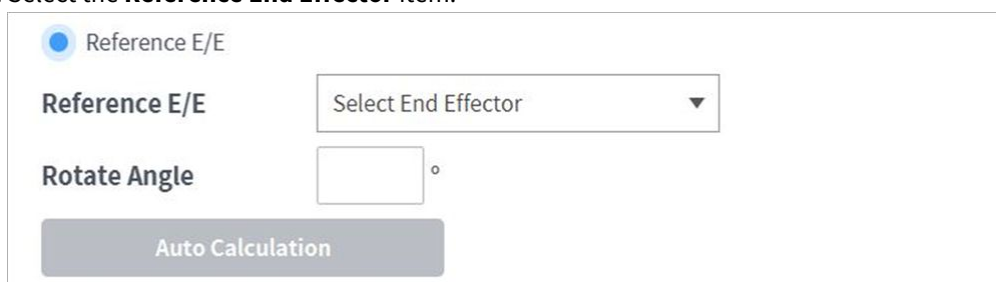

4. Select the end effector to copy.

Reference E/E

5. Configure the tool Z-axis rotate angle of the configuring end effector and reference end effector.

Rotate Angle °

6. Click the **Auto Calculate** button on the bottom, check whether the calculated TCP offset is automatically entered and tap the **Confirm** button.

Offset ⓘ

X	0.000 mm	Y	0.000 mm	Z	0.000 mm	A	0.0°	B	0.0°	C	0.0°
---	----------	---	----------	---	----------	---	------	---	------	---	------

Note

The configuring end effector and base end effector must be symmetrical on the tool Z axis.

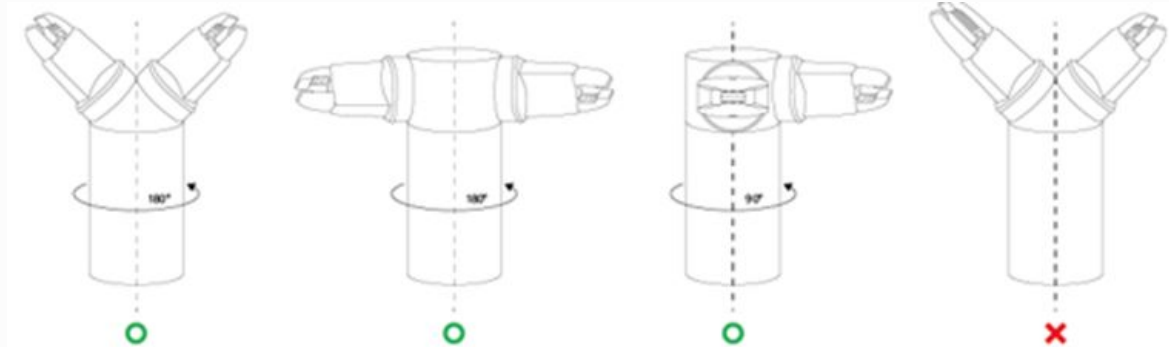

4.7.4 Machine Tool Setting

Machine tools are the main work devices that interact with the robot, and the machine tools that can be registered in the Workcell Manager are as follows:

Category	Type	Description
Turning Center	Turning Center	It turns cylindrical materials to allow the material to be cut to the desired shape using a tool turret.
Press Machine	Press Machine	This is a machine that compresses a flat material to form a desired shape.

Category	Type	Description
Injection Machine	Molding Machine	This is a device that injects materials such as plastic into a mold and forms it into the desired shape.

Machine tool settings are similar to those of the gripper settings.

For more information about each machine tool settings, refer to the separate manuals provided.

4.7.5 Peripheral Setting

Peripherals are Workcell items that are not categorized as a robot, end effector or machine tool, but interact with the robot. Peripherals that can be registered in the Workcell Manager are as follows:

Category	Type	Description
Feeder	Shooting Bolt Feeder	This is a device that supplies bolts to the end of a screwdriver using a tube and air pressure.
	Pallet (4 Point)	This is a cradle that allows the target to be placed in a set formation. (Square, stack, and linear patterns available)
	Pick-up Bolt Feeder	This is a device that supplies bolts for screwdriving.
Others	Button	This is a device that sends On/Off signals.
	External Encoder	Externally installed Encoder Setting
Vision	Smart Vision Camera	This is a device that corrects the target position based on video information.
Conveyor Tracker	Conveyor Tracker	Externally installed Conveyor Operation Setting

For more information about peripheral settings, refer to the separate **Reference Manual** provided.

Others

The others category settings are similar to those of the gripper settings. For more information about other category settings, refer to the separate manuals provided.

Vision

For more information about Vision settings, refer to the separate manuals provided.

4.8 Tool Setting

It sets the tool center point, weight and shape, which act as the basis for robot movement. It is possible to set and enable multiple end effectors and the tool center point, weight and shape on the Workcell Manager screen, so the tool center point, weight and shape of the end effector to be used must be set in **Tool Settings** of the tool.

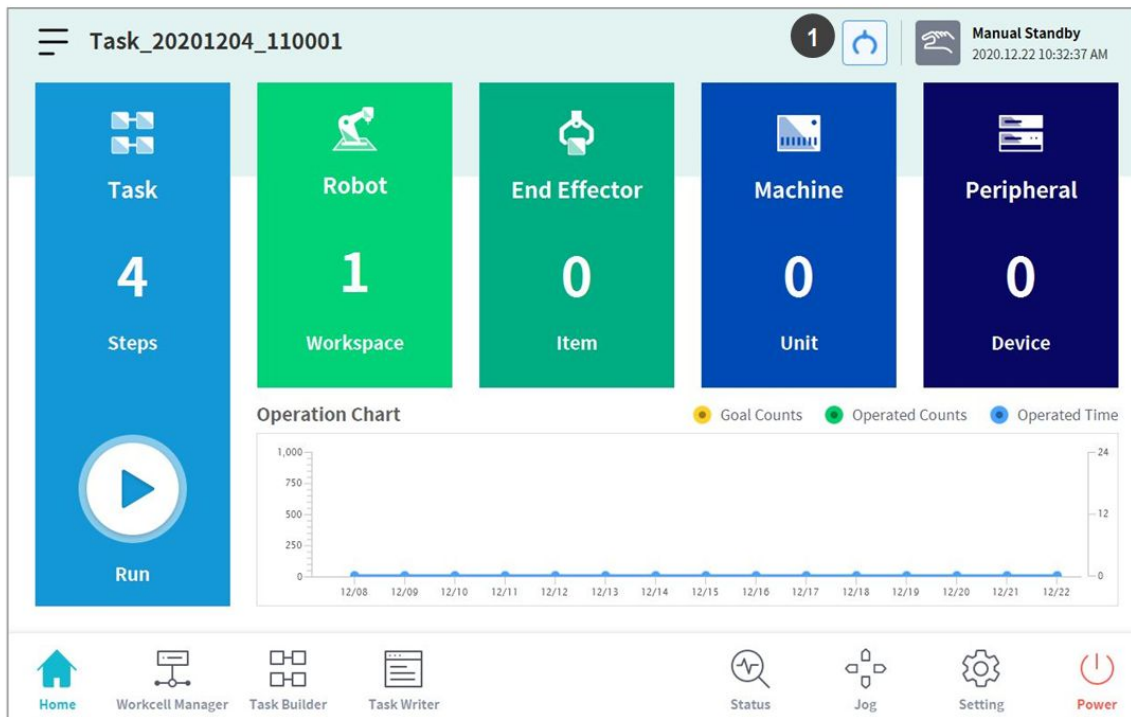

No.	Item	Description
1	Tool Setting Button	It runs the Tool Setting popup.

1. Select the **Tool Setting button**.
2. Select the desired Workcell item from the **Tool Center Point, Weight or Tool Shape**.

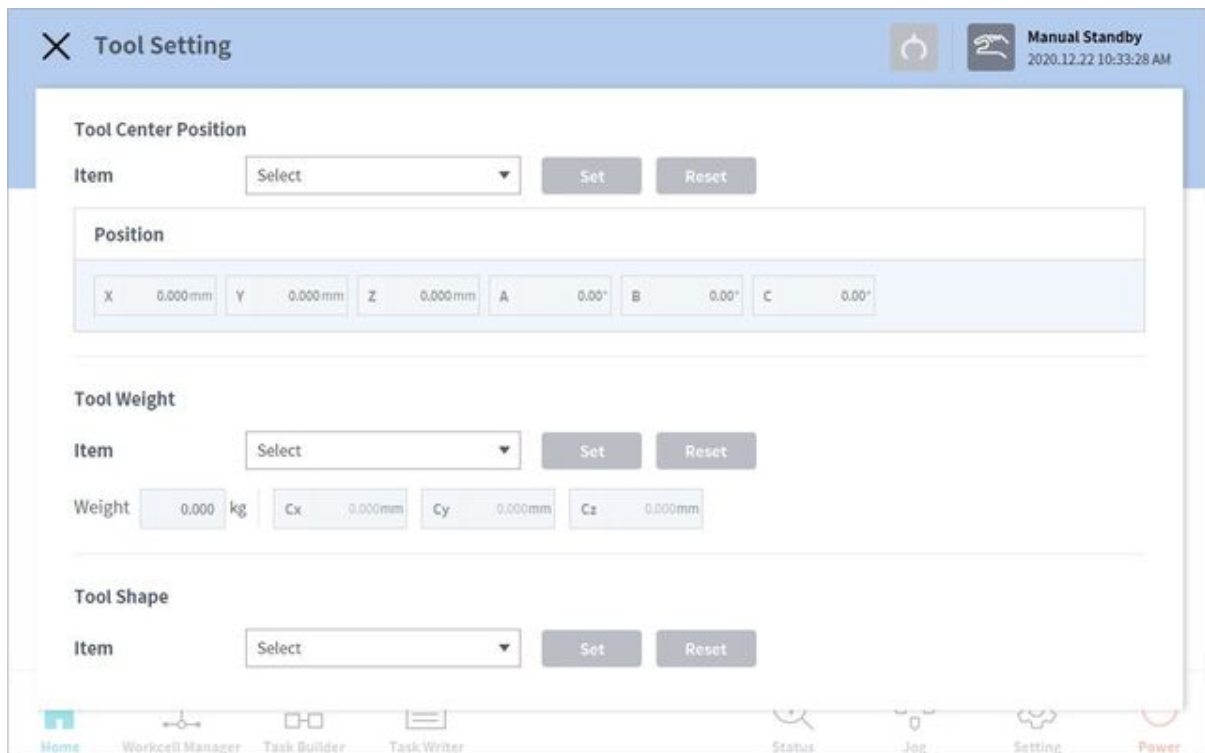

3. Press the **Setting** button to save the tool center point, weight or shape of the corresponding Workcell item.

Note

The robot's tool center point and tool weight can be set to default where no input is made by pressing the **Reset button**

4.9 Manual Robot Operation

This section describes how to operate the robot manually.

4.9.1 Jog Function

In **Jog** mode, the user can navigate the entire work space or set the operation space the user configured as the robot operation space. The movement angle of each axis can be limited according to the selected operation space and joint angle limit of the safety setting.

To use the jog function, tap the  **Jog** button on the main menu.

- In Auto mode, the **Jog** button is disabled, so the function is unavailable.
- The Jog function cannot be used during **Servo Off**.
- The robot is operated manually in the **Jog** screen, so the robot only moves when the Jog button is pressed.
- It is possible to move the robot based on the current position on the **Jog** tab screen.
- The robot can be moved by configuring the target angle/coordinates on the **Move** tab screen.

- It is possible to configure the reference coordinates on the **Jog** tab screen and **Move** tab screen as a joint or task.
- The robot's alignment reference is selected in the **Align** tab screen.

Note

- On the **Align** screen, if the safety signal I/O, POS_3_ENABLE_SWITCH, is set, the Servo On and Jog functions are available only if this signal is inputted.
- If the robot cannot be navigated due to being located in a space other than the operation space of the **Jog** mode, set the robot operation space to “None” to allow the robot to be navigated.

Align Screen

The robot's alignment reference can be set on the **Align** screen.

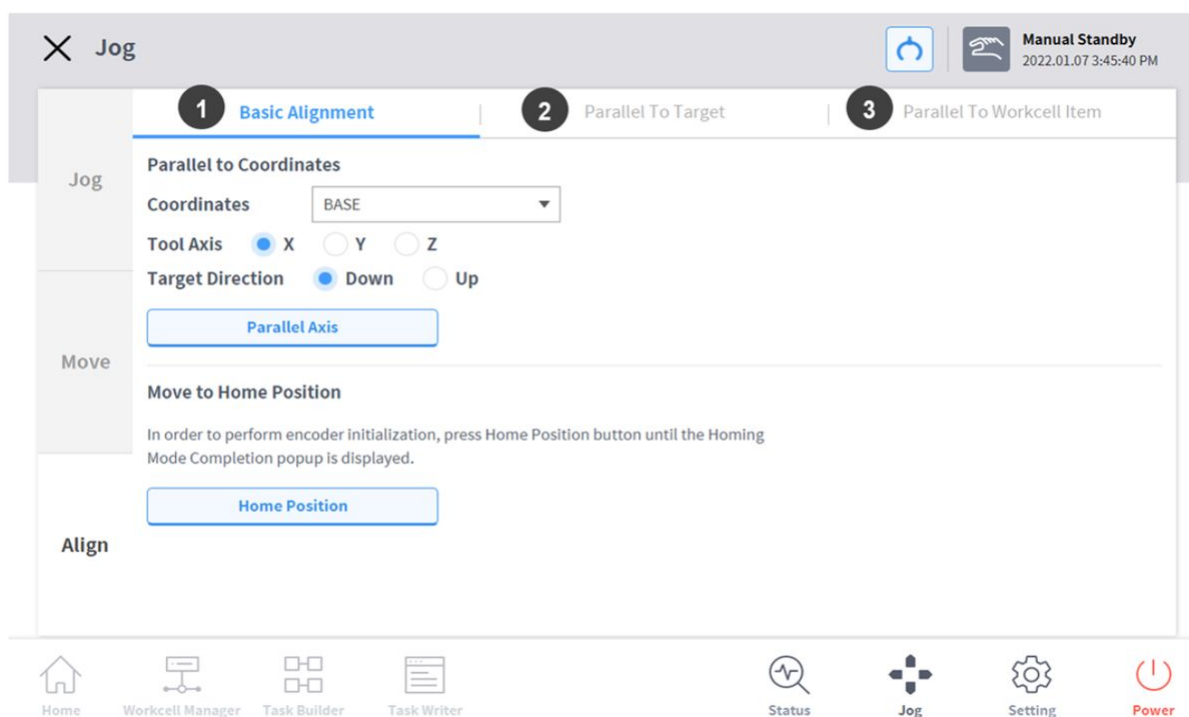

No.	Item	Description
1	Basic Alignment	It aligns the TCP based on the Base/World axis and target direction.
2	Align with Target	Aligns the TCP with the target.
3	Align with Workcell Item	Aligns the TCP with Workcell item.

Alignment based on Base Axis

When the work item is positioned in the Base axis direction of the robot, it is possible to align the TCP on the workpiece before workpiece teaching.

The teaching pose can be configured in line with the Base Coordinates axis, making it is easy to specify a teaching pose.

To perform teaching after locking the pose, use the plane or line locked direct teaching function with "Cockpit" buttons.

To align the robot TCP based on the base axis, follow these steps:

1. Select the **Align** tab and select the **Basic Alignment** tab.

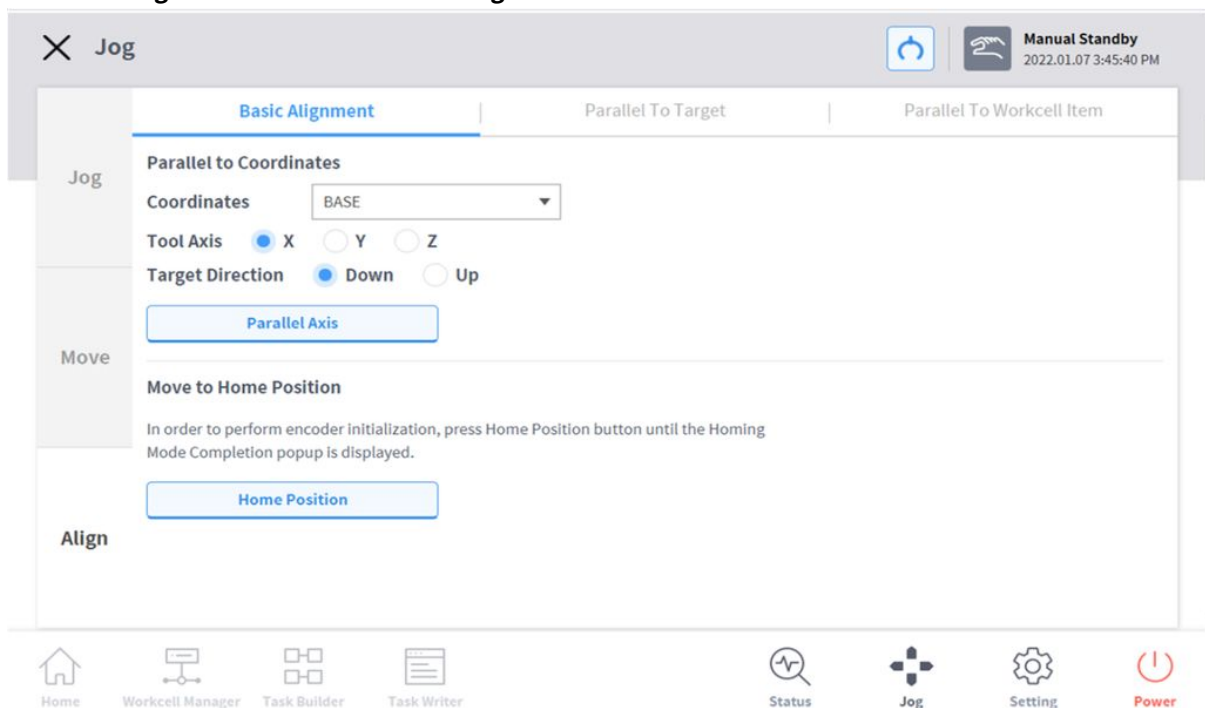

2. Select the reference coordinates for alignment.



3. Select the reference tool axis.



4. Select the alignment direction.

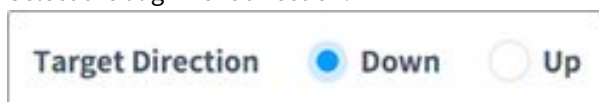

5. Tap and hold the **Parallel Axis** button to align the axis.

Alignment based on Target

This is a useful function if the workpiece is aligned with the TCP in an axis direction for workpiece teaching. To perform teaching after locking the pose, use the plane or line locked direct teaching function with cockpit buttons.

To align the robot TCP based on target, follow these steps:

1. Select the **Align** tab and select **Parallel To Target** tab.

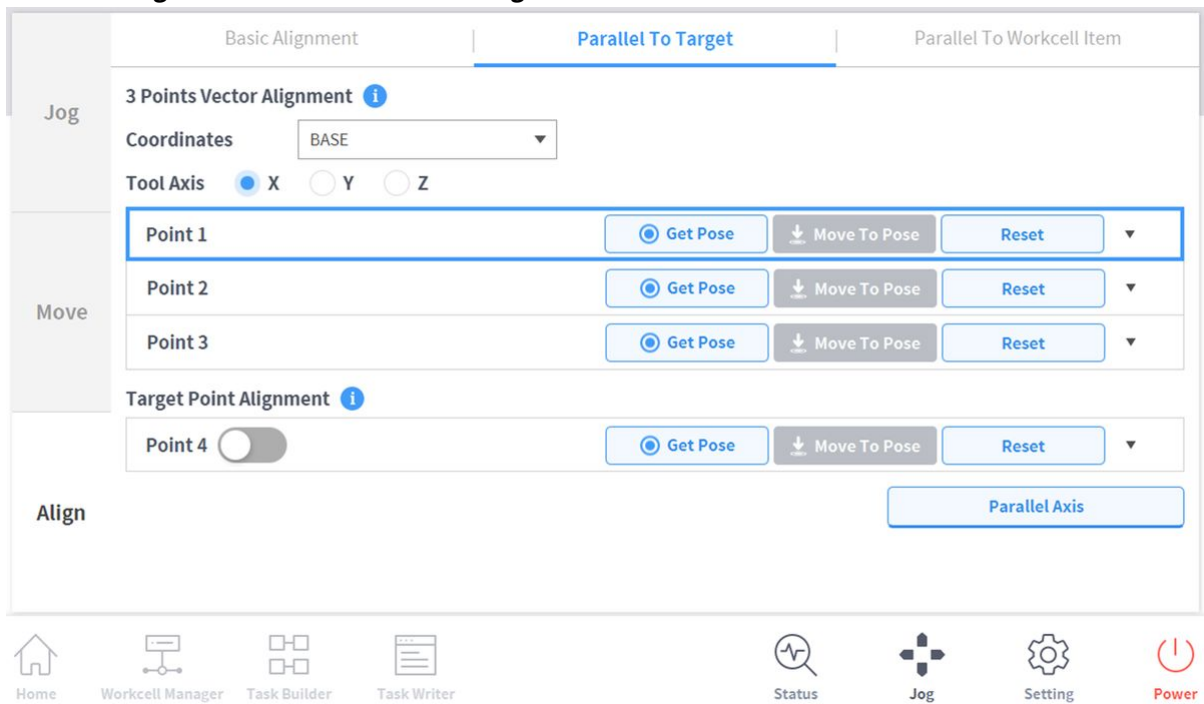

2. Select the reference coordinates for alignment.



3. Select the tool axis to align.

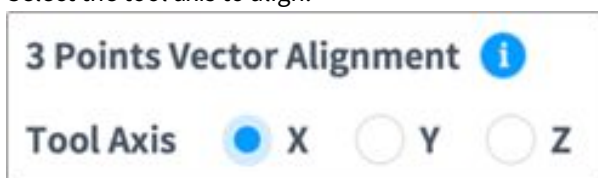

4. Move the robot to the desired position and tap **Point 1**.
5. Tap the **Save Pose** button of **Point 1.4**

6. **Point 2 and Point 3** are set in the same way. When settings are complete, a virtual vector area is set based on the three points.

Point 1	<input type="radio"/> Get Pose	<input type="button" value="Move To Pose"/>	<input type="button" value="Reset"/>	▲
Point 2	<input type="radio"/> Get Pose	<input type="button" value="Move To Pose"/>	<input type="button" value="Reset"/>	▲
Point 3	<input type="radio"/> Get Pose	<input type="button" value="Move To Pose"/>	<input type="button" value="Reset"/>	▲

7. (Optional) To set the TCP direction and position together, press the "toggle" button of **Point 4** , move the robot to the desired position and tap the "Save Pose" button.

8. Tap and hold the **Align Axis** button to align the axis.

- Place the 6-axis head 150 mm above the target in the Z-axis direction.

Alignment based on Workcell Items

Aligns the robot TCP based on the Workcell item.

1. Select the **Align** screen and select the **Parallel To Workcell Items** tab.
2. Select the desired item from the **Workcell Item**.
3. Select the alignment direction.
4. Tap and hold the **Align Axis** button to align the axis.

Note

The sorting directions for [Alignment based on Target](#)(p. 291) and 'Alignment based on Workcell Items' are determined according to whether the teaching sequence of three points taught in the Workcell Item was clockwise or counter clockwise. [Refer to Figure below]

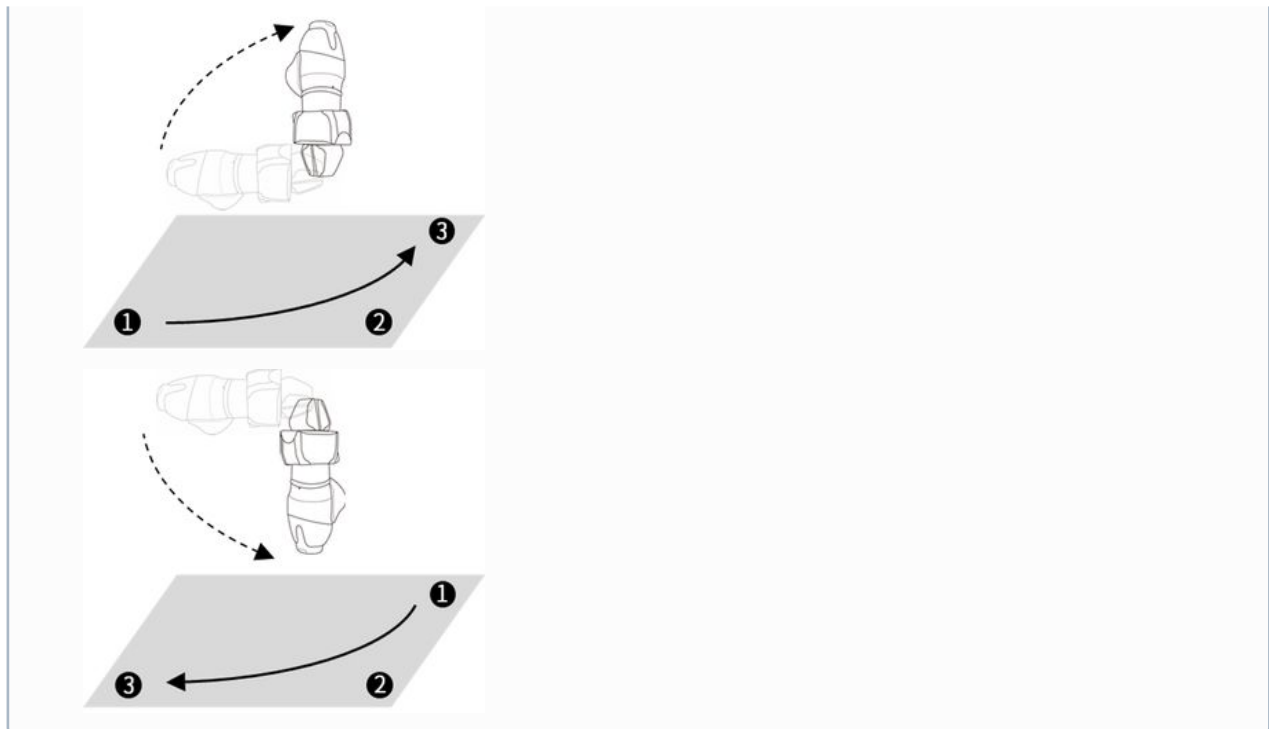

Go to Home

	Basic Alignment	Parallel To Target	Parallel To Workcell Item
Jog	Parallel to Coordinates Coordinates <input type="text" value="BASE"/>		
	Tool Axis <input checked="" type="radio"/> X <input type="radio"/> Y <input type="radio"/> Z Target Direction <input checked="" type="radio"/> Down <input type="radio"/> Up		
Move	<input type="button" value="Parallel Axis"/>		
	Move to Home Position In order to perform encoder initialization, press Home Position button until the Homing Mode Completion popup is displayed.		
Align	<input type="button" value="Home Position"/>		

Moves the robot to the default home position or the user home position configured in **Settings** on the main menu.

1. Select the **Align** tab and select the **Basic Alignment** tab.
2. Tap and hold the **“Home Position”** button to move the robot to the home position.

⚠ Caution

- When a robot or joint of a robot is being swapped, User Home Position must be reset using the teach pendant.
- When performing a backup/restore, you must reset the user home position on the teach pendant.
- The User Home Position setting of DART Studio is not reflected on the teach pendant. If the User Home Position is set using DART Studio and then used with the teach pendant, the User Home Position must be reset.

Jog Plus (Jog+)

Using Jog+ allows you to use the jog feature simultaneously while performing different work. This can be used when precise movement to the target point is required during robot teaching.

Jog Plus can be activated in the following ways.

1. Press the jog button for more than 1 second in the main menu at the bottom of the screen.
2. The Jog Plus screen is activated.

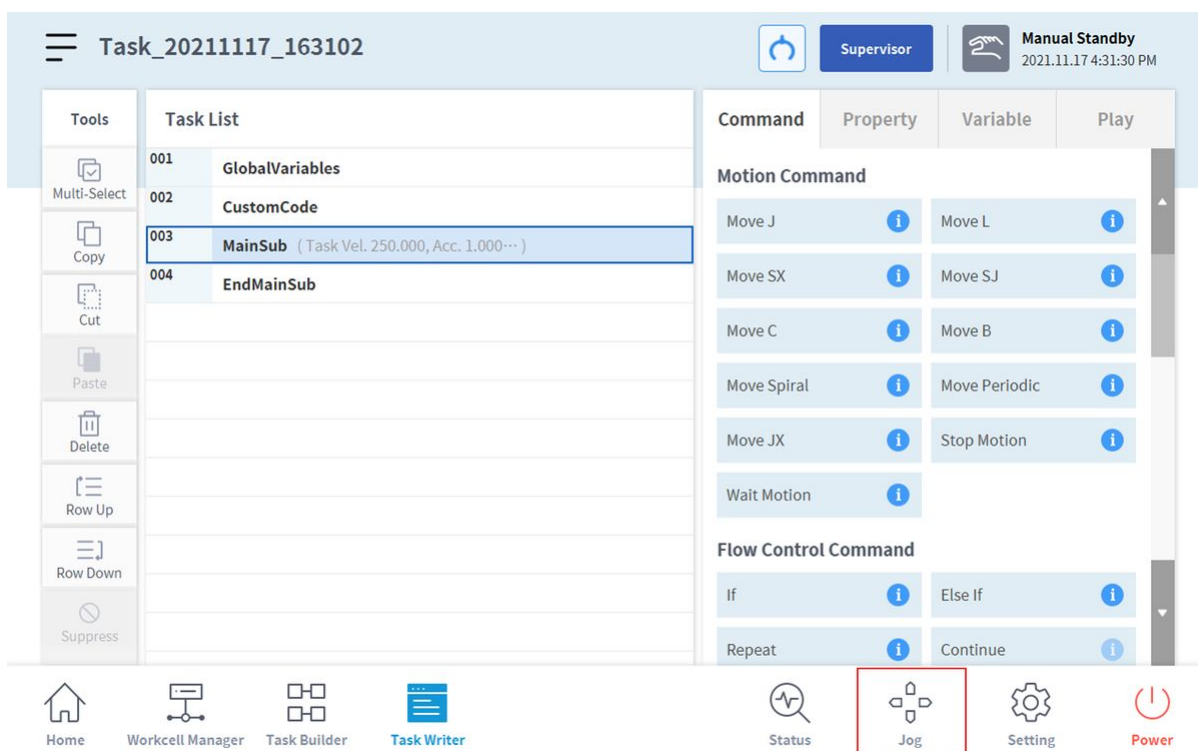

3. Jog Plus can be deactivated by pressing the 'X' button.

Task_20211117_163102 Supervisor Manual Standby 2021.11.17 4:32:54 PM

Tools	Task List	Command	Property	Variable	Play
Multi-Select	001 GlobalVariables	Motion Command Move J <input type="button" value="i"/> Move L <input type="button" value="i"/> Move SX <input type="button" value="i"/> Move SJ <input type="button" value="i"/> Move C <input type="button" value="i"/> Move B <input type="button" value="i"/> Move Spiral <input type="button" value="i"/> Move Periodic <input type="button" value="i"/> Move JX <input type="button" value="i"/> Stop Motion <input type="button" value="i"/> Wait Motion <input type="button" value="i"/>			
Copy	002 CustomCode				
Cut	003 MainSub (Task Vel. 250.000, Acc. 1.000...)				
Paste	004 EndMainSub				
Delete					
Row Up					

X	0.00 mm
Y	34.50 mm
Z	1452.50 mm
A	0.00°
B	0.00°
C	0.00°
J1	0.00°
J2	0.00°
J3	0.00°
J4	0.00°
J5	0.00°
J6	0.00°

Display Coordinates BASE Tool

Joint J1 J2 J3 J4 J5 J6

Task X Y Z Rx Ry Rz

Tool Center Position Select

Angle Increment 0.0°

Position Increment 0.0 mm

Tool Weight Select

Force BASE

X 0.00 N
Y 0.00 N
Z 0.00 N

Task_20210728_133558 Manual Standby 2021.07.28 2:34:54 PM

Tools	Task List	Command	Property	Variable	Play												
Multi-Select	001 GlobalVariables (Global)	Move J (Joint) <input type="button" value="Confirm"/> Absolute <input checked="" type="radio"/> Relative <input type="radio"/> Select Variable <input type="button" value="Get Pose"/> <input type="button" value="Move To"/> <input type="button" value="Reset"/> <table border="1"> <tr> <td>J1</td><td>0.0°</td> <td>J2</td><td>0.0°</td> <td>J3</td><td>90.00°</td> </tr> <tr> <td>J4</td><td>0.00°</td> <td>J5</td><td>90.00°</td> <td>J6</td><td>0.0°</td> </tr> </table>				J1	0.0°	J2	0.0°	J3	90.00°	J4	0.00°	J5	90.00°	J6	0.0°
J1	0.0°					J2	0.0°	J3	90.00°								
J4	0.00°					J5	90.00°	J6	0.0°								
Copy	002 Start MainSub (Task Vel. 250.000, Acc. 1.0...)																
Cut	003 MoveJ																
Paste	004 WeightMeasure (Global_a)																
Delete	005 Popup (Message, text copy test)																
Row Up	006 End MainSub																

X	0.00 mm
Y	34.50 mm
Z	1452.50 mm
A	0.00°
B	0.00°
C	0.00°
J1	0.00°
J2	0.00°
J3	0.00°
J4	0.00°
J5	0.00°
J6	0.00°

Display Coordinates BASE Tool

Joint J1 J2 J3 J4 J5 J6

Task X Y Z Rx Ry Rz

Tool Center Position Select

Angle Increment 0.0°

Position Increment 0.0 mm

Tool Weight Select

Force BASE

X 0.00 N
Y 0.00 N
Z 0.00 N

No.	Item	Description



1	Current robot pose	Displays the robot pose based on the set display coordinates.
2	Manual Mode Speed	Configures the robot movement speed in manual mode. The speed can be adjusted by dragging the slider pointer. If the slider pointer is at 100%, the corresponding maximum joint speed on the Jog tab will be 30 deg/s, and the maximum task speed will be 250 mm/s. This speed influences the speed controlled by the jog and movement buttons.
3	Reference Point Setting	It configures the reference point to align the task coordinate. <ul style="list-style-type: none"> • Base: It configures the task coordinate based on the robot base. • World: Sets task coordinates based on the set World Coordinates. • Tool: It configures the task coordinate based on the tool installed on the end of the robot's six-axis.
4	Select Axis	Selects the axis to move. <ul style="list-style-type: none"> • Joint Tab: Select one axis among J1 - J6. • Task Tab: Select one axis among X - Rz.
5	Select Increment	<ul style="list-style-type: none"> • Enters a number regarding how much the selected axis is to be moved.
6	Move – Button	If the button is held down, the selected axis is moved in the - direction in accordance with the increment location.
7	Move – Button	If the button is held down, the selected axis is moved in the + direction in accordance with the increment location.
8	Force Monitoring	Displays the occurring external force based on the selected coordinate system.
9	TCP Setting:	Sets TTCP.
10	Tool Weight Indicator	Sets the tool Weight.
11	Change Jog+ location	Changes the Jog+ location to the top or bottom of the screen.

Jog Screen

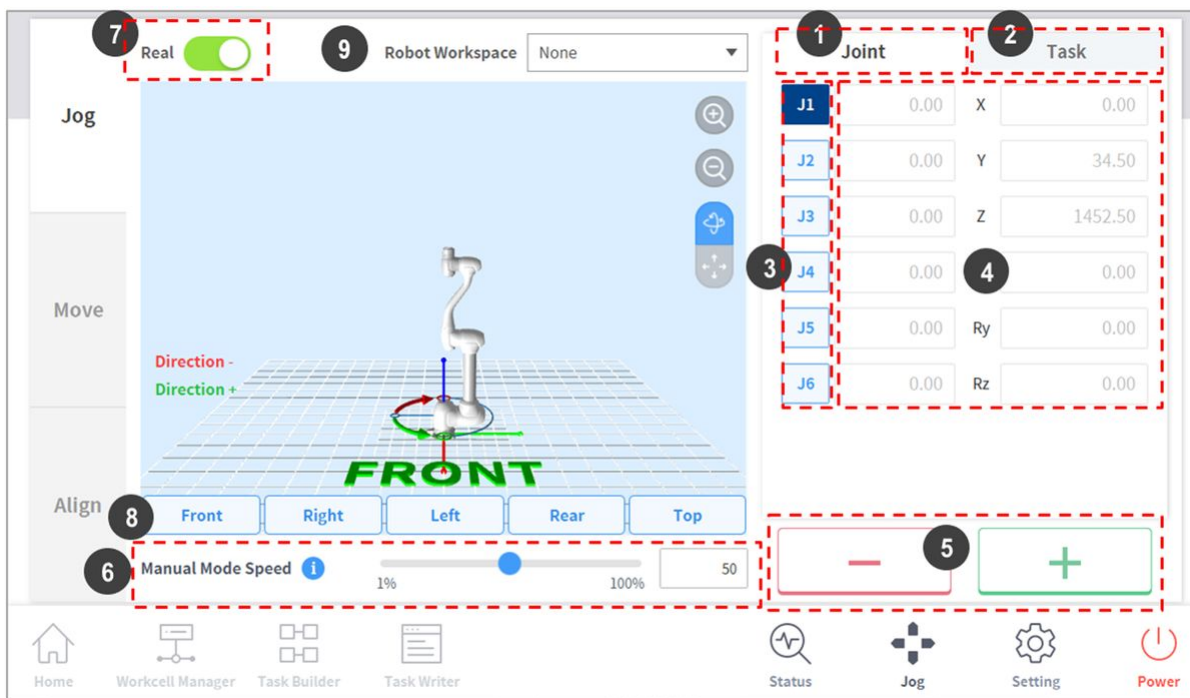
It is possible to navigate based on the current robot position on the jog screen.



N o.	Item	Description
1	Joint	It configures the joint as the reference coordinate for jog mode.
2	Task	It configures the task as the reference coordinate for jog mode.
3	Select Axis	Select an axis to move in jog mode. <ul style="list-style-type: none"> • Joint Tab: Select one axis among J1 - J6. • Task Tab: Select one axis among X ~ Rz.
4	Coordinate Display	The coordinates of the robot currently operated in Jog mode is displayed. If the robot position changes by pressing the direction button, the coordinate also changes.
5	Direction	It moves the robot in the + or - direction on the selected axis.
6	Manual Mode Speed	Configures the robot movement speed in manual mode. The speed can be adjusted by dragging the slider pointer. If the slider pointer is at 100%, the corresponding maximum joint speed on the Jog tab is 30 deg/s, and the maximum task speed is 250 mm/s. This speed influences the speed controlled by the jog and movement buttons.

7	Real Mode	It configures whether to operate the robot in real mode while in jog mode. <ul style="list-style-type: none"> On (): The robot actually moves. Off (): The simulator operates.
8	Simulator Alignment	It selects the alignment direction of the robot displayed in the simulator. Pressing each direction button aligns the robot in the corresponding direction.
9	Robot Workspace	It displays robot workspace information registered in the Workcell Manager in the Jog Simulator. Press the drop-down menu to select the workspace to display.

Note

- TCP Speed Limit: The highest operation speed during jog and movement button operation is limited to 250 mm/s according to safety policies.
- If the robot stops due to reaching the joint limit or if a collision is detected while moving the robot with jog mode, set the safety recovery mode and move the robot to be positioned within the joint angle limit. For more information about Safety Recovery Mode, refer to [Safety Recovery Mode](#)(p. 305).



Execute based on World Coordinates

To move the robot based on World Coordinates, follow these steps:

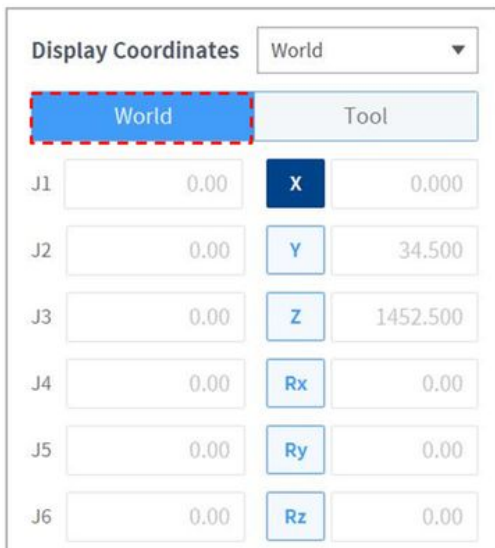
1. Select the **Task** tab on the **Jog** screen.
2. Select the display coordinates to be used as World Coordinates and select **World** as the reference point of the task coordinates.



Display Coordinates		World	
	World	Tool	
J1	0.00	X	0.000
J2	0.00	Y	34.500
J3	0.00	Z	1452.500
J4	0.00	Rx	0.00
J5	0.00	Ry	0.00
J6	0.00	Rz	0.00

3. Select World Coordinates to move.
4. Press and hold the Direction Button( , ) to move the corresponding axis.

Execute based on Robot Base

To move the robot based on the robot base, follow these steps:

1. Select the **Task** tab on the **Jog** screen.
2. Select the display coordinates to be used as the base and select the **Base** as the reference point of the task coordinates.

Joint		Task	
Display Coordinates		BASE	
BASE		Tool	
J1	0.00	X	X 0.000
J2	0.00	Y	Y 34.500
J3	0.00	Z	Z 1452.500
J4	0.00	Rx	A 0.00
J5	0.00	Ry	B 0.00
J6	0.00	Rz	C 0.00

3. Select the Base Coordinates to move.
4. Press and hold the Direction Button(**+** , **-**) to move the corresponding axis.

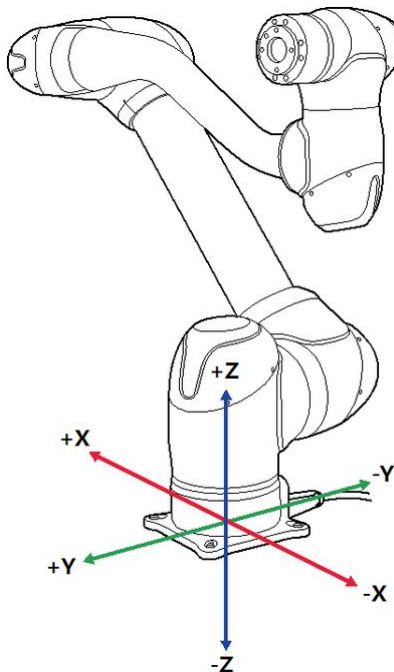

Note

Safety area does not apply in virtual mode.

Execute based on Joint

To adjust the angle based on the robot joint, follow these steps:

1. Select the **Joint** tab on the **Joint** screen.
2. Select the axis (J1-J6) to adjust the angle.

Joint		Task	
J1	0.00	X	0.00
J2	0.00	Y	34.50
J3	0.00	Z	1452.50
J4	0.00	Rx	0.00
J5	0.00	Ry	0.00
J6	0.00	Rz	0.00

3. Press and hold the Direction Button (**+** , **-**) to adjust the angle of the corresponding axis.

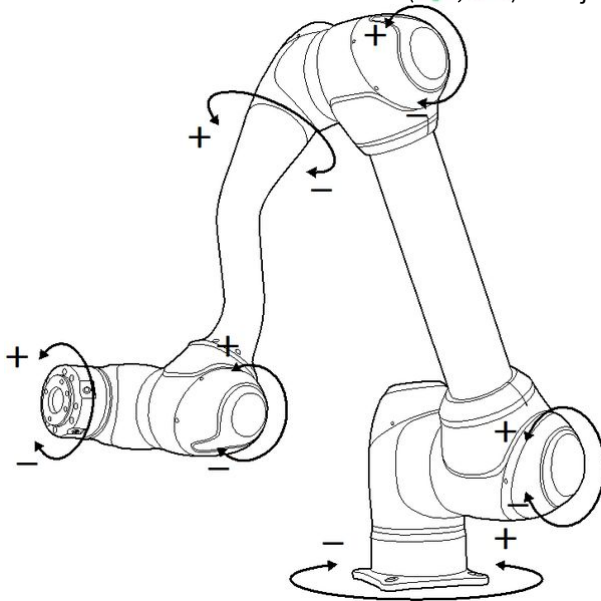

Note

Safety area does not apply in virtual mode.

Execute based on Robot Tool

To move the robot based on the robot tool, follow these steps:

1. Select the **Task** tab on the **Jog** screen.

- Select Base or World as the display coordinates and set the **Tool** based on the reference point of the task coordinates.

Joint		Task	
Display Coordinates		BASE	
BASE		Tool	
J1	0.00	X	0.000
J2	0.00	Y	34.500
J3	0.00	Z	1452.500
J4	0.00	Rx	0.00
J5	0.00	Ry	0.00
J6	0.00	Rz	0.00

- Select the Tool Coordinates to move.
- Press and hold the Direction Button (**+** , **-**) to move the corresponding axis.

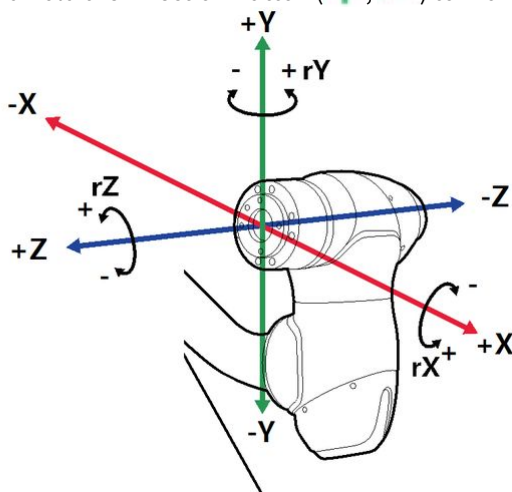

Note

- Safety area does not apply in virtual mode.
- Rx, Ry and Rz are executed according to TCP (tool center position).

Movement Screen

The robot can be moved by target angle/coordinates on the Move screen.

If the coordinates the robot must move to are known or if the robot must be moved up to coordinates in decimal points, it is possible to move the robot by entering coordinates.

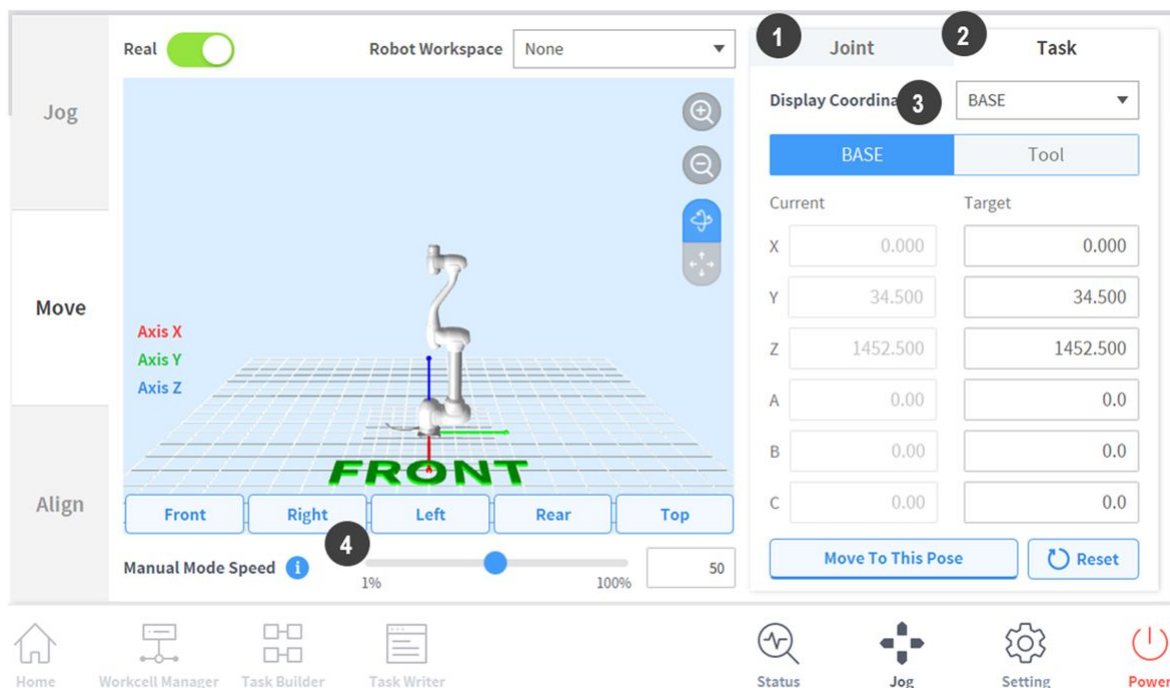

N o.	Item	Description
1	Joint	It configures the reference coordinate to use when moving the robot with a jog.
2	Task	It configures the reference angle to use when moving the robot with a jog.
3	Reference Point Setting	It configures the reference point to align the task coordinate. <ul style="list-style-type: none"> • Base: It configures the task coordinate based on the robot base. • World: Sets task coordinates based on the set World Coordinates. • Tool: It configures the task coordinate based on the tool installed on the end of the robot's six-axis.
4	Manual Mode Speed	It configures the robot's movement speed in manual mode. The speed can be adjusted by dragging the slider pointer. If the slider pointer is at 100%, the corresponding maximum joint speed on the Move tab is 30 deg/s, and the maximum task speed is 250 mm/s. The speed influences the jog and button operation speed.

Move with Base Reference Coordinates

To move the robot based on base coordinates, follow these steps:

1. Select the **Move** tab and select the **Task** tab.

Display Coordinates: BASE

BASE | Tool

	Current	Target
X	0.000	0.000
Y	34.500	34.500
Z	1452.500	1452.500
A	0.00	0.0
B	0.00	0.0
C	0.00	0.0

Move To This Pose | Reset

2. Select Base as the display coordinates and select the **Base** tab.
3. Configure the pose to move with reference to the base.
4. Tap and hold the **Move to Corresponding Pose** button to go to the set coordinate.

Move with World Coordinates Reference Coordinates

To move the robot based on World Coordinates, follow these steps:

1. Select the **Move** tab and select the **Task** tab.

Display Coordinates: World

World | Tool

	Current	Target
X	0.000	0.000
Y	34.500	34.500
Z	1452.500	1452.500
A	0.00	0.0
B	0.00	0.0
C	0.00	0.0

Move To This Pose | Reset

2. Select World as the display coordinates and select the **World** tab.

3. Configure the pose to move with reference to the World Coordinates.
4. Tap and hold the **“Move to Corresponding Pose”** button to go to the set coordinate.

Move with Tool Reference Coordinates

To move the robot based on tool coordinates, follow these steps:

1. Select the **Move** tab and select the **Task** tab.
2. Select the **Tool** tab.
3. Configure the pose to move with reference to the tool.
4. Tap and hold the **Move to Corresponding Pose** button to go to the set coordinate.

Moving with Angle Setting

To move the robot at a specific angle, follow these steps:

1. Select the **Move** tab and select the **Joint** tab.
2. Enter the target angle of the robot joint.

	Joint	Task
	Current	Target
J1	<input type="text" value="-7.57"/>	<input type="text" value="0.0"/>
J2	<input type="text" value="0.00"/>	<input type="text" value="0.0"/>
J3	<input type="text" value="0.00"/>	<input type="text" value="0.0"/>
J4	<input type="text" value="0.00"/>	<input type="text" value="0.0"/>
J5	<input type="text" value="0.00"/>	<input type="text" value="0.0"/>
J6	<input type="text" value="0.00"/>	<input type="text" value="0.0"/>

3. Enable the **Real Mode**.

Real
Robot Workspace

4. Tap and hold the **Move to Corresponding Pose** button to adjust the robot joint angle.

4.9.2 Safety Recovery Mode

If there is an error with a continuing safety violation or if a robot needs to be packed for transportation, the user can use the **Safety Recovery Mode** to configure the position and angle of the robot.

- **Software Recovery:** In Servo Off status, if a safety violation error situation caused by position-related safety violations, such as the robot exiting the operation area or violating prohibited areas, occurs or force is continuously applied when the robot is stopped due to colliding with a fixed object, **Servo On** or **Jog** cannot be set even when attempting to reset the robot to a normal state using the **Jog** or program. In such cases, **Software Recovery** mode is used to reset the robot to normal.
- **Packaging Mode:** For packaging and transporting the robot, the robot can be set to predefined values (which go beyond the normal operation angle limit) for packaging.

Using Software Recovery Mode

To use the software recovery mode, follow these steps:

1. Tap the **Safety Recovery** button in the **Status** window.



2. Tap each joint button on the right side of the Software Recovery screen, and use **+** and **-** button to set the position. Or press the **1**, **2** and **3** buttons of the **Cockpit** to adjust the joint angle by direct teaching.
 - For more information about the cockpit buttons, refer to [Cockpit Button \(five buttons\)](#)(p. 310) or [Cockpit Button \(six buttons\)](#)(p. 312).
 - Changes made to the setting are reflected on the simulation window on the left in real time.

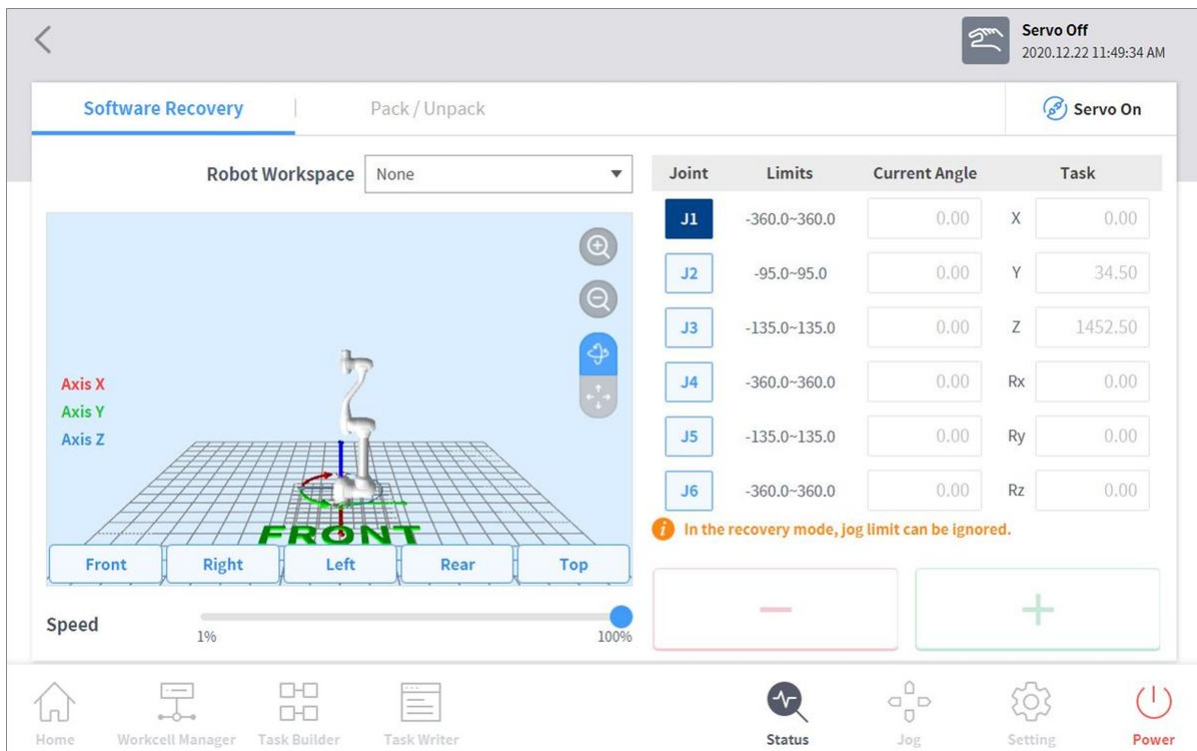

3. When the setting is complete, tap the X button on the top left.

Caution

Software recovery mode cannot be used when the joint angle limit exceeds 3 degrees.

Packaging Mode Setting

To configure the packaging mode, follow these steps:

1. Tap the **Safety Recovery** button in the **Status** window.



2. Select the **Packaging Mode** tab.

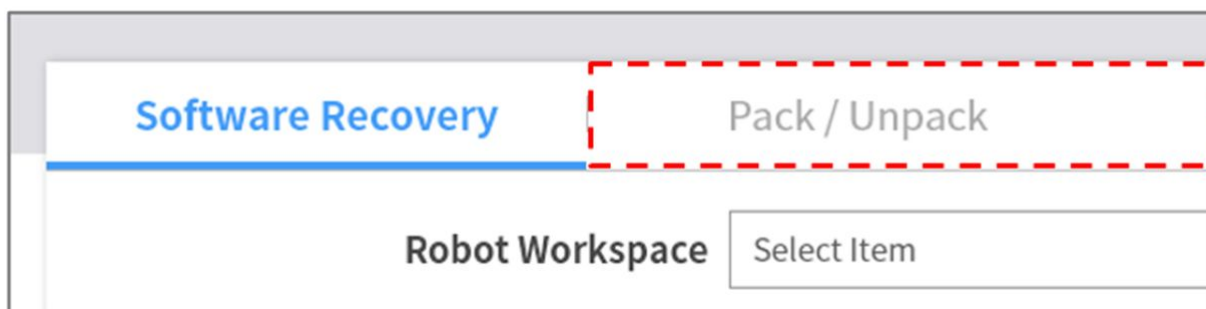

3. Tap the **Servo On** button to activate recovery standby mode.



4. Tap the **Go to Packaging Pose** button.

- The robot automatically moves to the set packaging pose.

Software Recovery | **Pack / Unpack** | Servo On

Package Mode

Model Name M1013

Pack

M1013	J1	J2	J3	J4	J5	J6
Packaging Pose	0.00	0.00	160.00	0.00	20.00	0.00
Joint Limit(-/+)	360.00	120.00	160.00	360.00	135.00	0.00

Unpack

4.9.3 Backdrive Mode

Backdrive allows the robot joint control with only the brake and without power driving the motor. This function is used when the robot cannot return to normal with **Safety Recovery** mode or Hand-guiding. With **Backdrive** mode, the user can engage or disengage the brake of each joint.

The process of setting **Backdrive** mode is as follows:

1. Tap the **Status** button on the main menu and tap the **Backdrive**

- If the **Backdrive** button is not enabled, press and release the Emergency Stop button or press the **Servo Off** button to enable it.

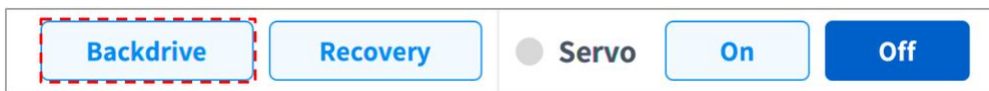

2. Tap the **Start Backdrive Mode** button on the **Backdrive**

- Release / Hold buttons to release the brakes of each joint are enabled.
 - Release : Orange
 - Hold : Green

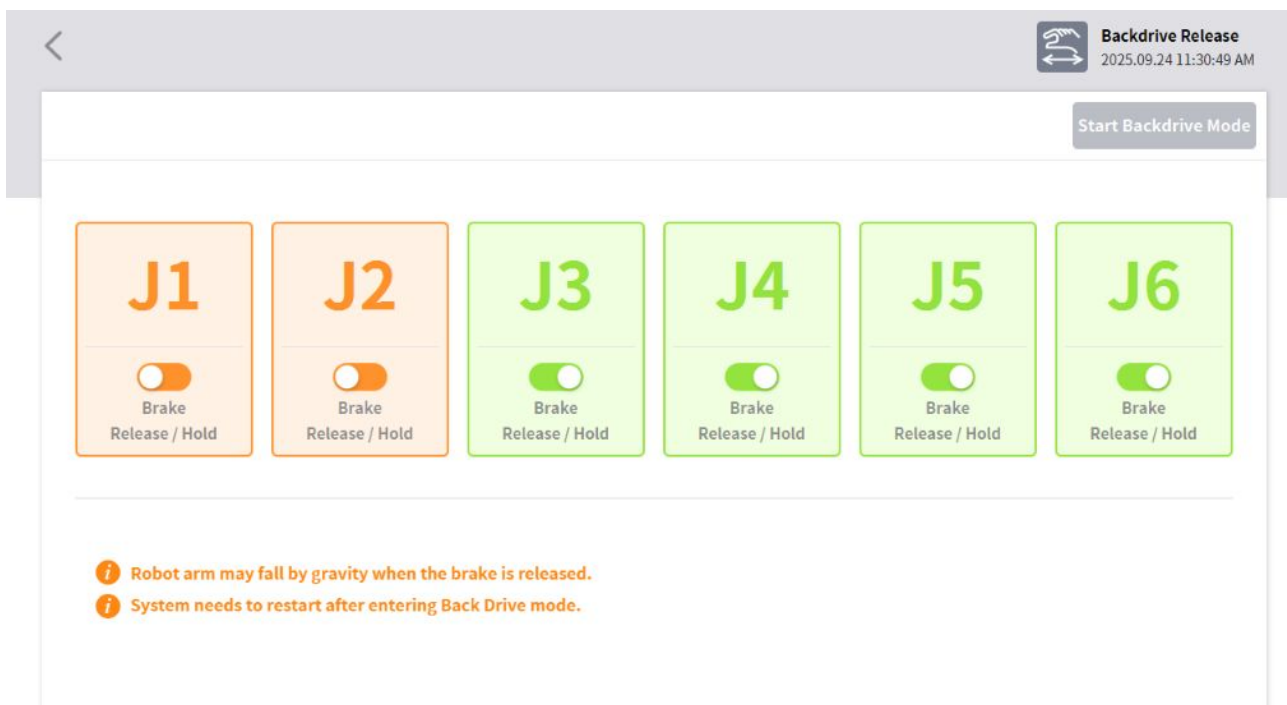

3. Set the brake of the joint to move as Release and move the robot by applying force.

- Due to the deceleration ratio of the decelerator inside the joint, the joint sagging speed due to the manipulator weight is not high, and movement speed when force is applied is also not high.
- If the decelerator malfunctions or if joints move at a speed faster than a certain speed during **Backdrive** mode, the brakes of all joints are applied automatically to ensure safety.

4. Set the brake Hold when the position change is complete.

5. Tap the **Power** on the main menu to shut down the operating program, tap and hold the power button on the top of the teach pendant to shut down the system, and press it again to turn on the system.

- **Backdrive** is released and work can resume normally.

Note

- Move each joint back to the normal work range individually in sequential order.
- If **Backdrive** mode is executed, the system must be rebooted to resume normal work again.
- Use caution as temporary sagging may occur depending on the axis location in **Backdrive** mode.

4.9.4 Hand-Guiding Operation

The user can change the robot's pose by directly moving the robot. Use the Hand-guiding button on the teach pendant or use the cockpit located on joint J6 to change the robot's pose.

⚠ Caution

- Before entering the robot's operation range, press the Hand-guiding button on the teaching pendant one or two times to make sure that the robot does not move when no external force is applied.
- If a tool is installed on the tool flange, configure the tool weight on the Workcell Manager and Jog screens on the teach pendant before changing the robot pose. If the Hand-guiding button is pressed without configuring the tool weigh, the robot may move abruptly.
- When using tools whose center of gravity are far away from the flange too much (400 mm or more), the robot can generate unstable vibrations. In such cases, operate the robot manually using the jog function rather than with Hand-guiding.
- Before Handguiding - freedrive and constrained motion, always verify the actual payload and settings are correct and payload is securely attached to the tool flange.

Teach Pendant Hand-Guiding Button

The user can change the robot's pose while holding down the Hand-guiding button located on the back of the teaching pendant.

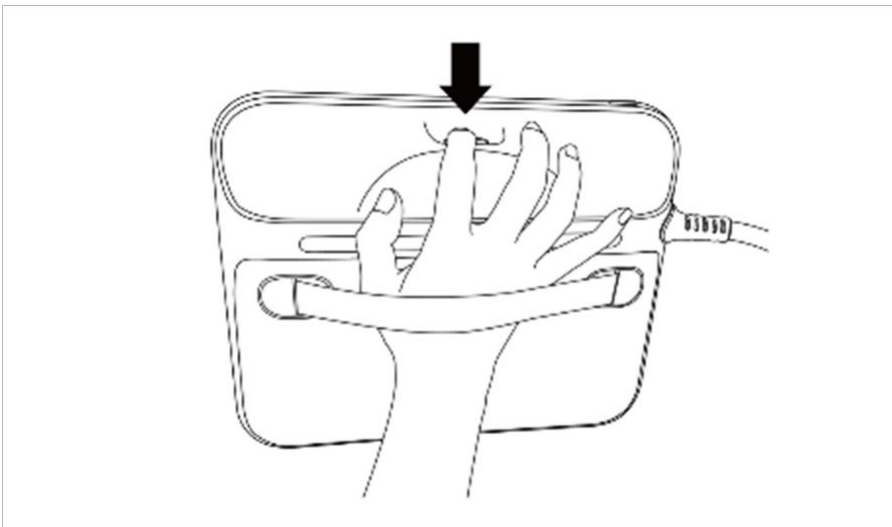

i Note

- By default, the Hand-guiding button can only be used in Manual mode, and it cannot be used in Auto mode when the task programs of **Task Builder** and **Task Writer** are operating.
- However, if the robot is set to the Hand-guiding Ready state with the Hand Guide command of the Task Writer, the button can be used even in Auto mode.

Cockpit Button (five buttons)

The user can change the robot's pose while holding down the Hand-guiding button or custom button on the cockpit.

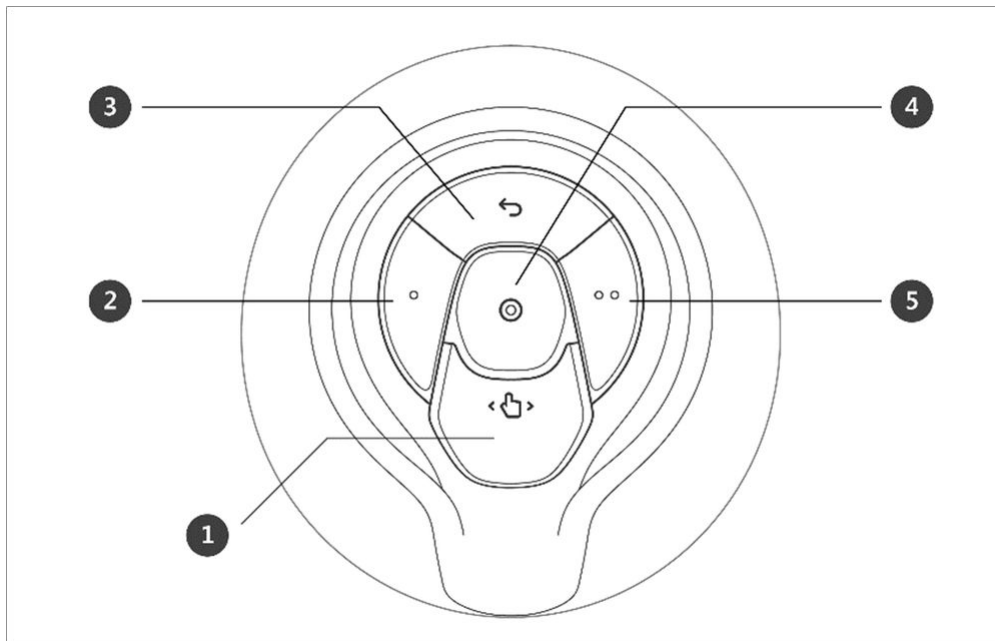

No.	Item	Description
1	Hand-Guiding Button	This button can be used to adjust or change the robot's pose.

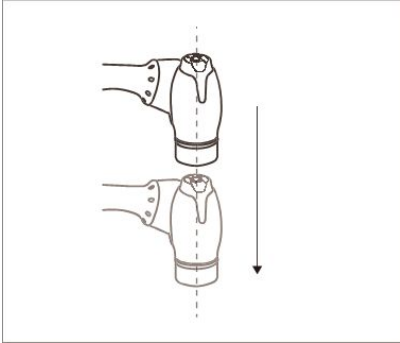
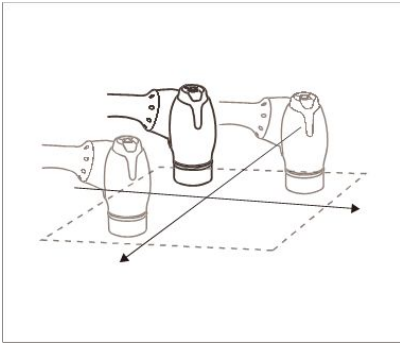
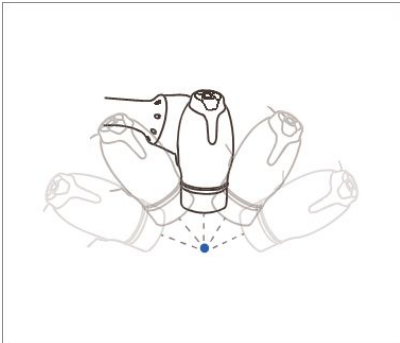
No.	Item	Description
2, 5	User Setting Button	<p>This button can modify the robot's pose by entering a pose according to a lock condition corresponding to a mode.</p> <ul style="list-style-type: none"> • Axis Lock : Changes the pose according to the Z-axis of the tool coordinates  <ul style="list-style-type: none"> • Surface Lock : Changes the pose according to the X-Y surface of the tool coordinates  <ul style="list-style-type: none"> • Point Lock : Changes the angle only from the reference point of the tool coordinates  <ul style="list-style-type: none"> • Angle Lock: Changes the position only with the current TCP angle locked

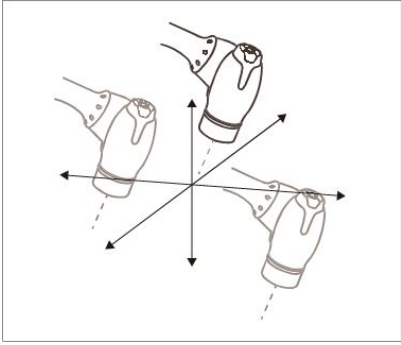
No.	Item	Description
		 <p>For more information about the settings, refer to Cockpit Setting(p. 357).</p>
3	Cancel Button	Deletes the most recently saved pose.
4	Save Pose Button	Saves the current robot pose. For more information, refer to Skill Command Work Point Setting with Cockpit Buttons (p. 336).

Cockpit Button (six buttons)

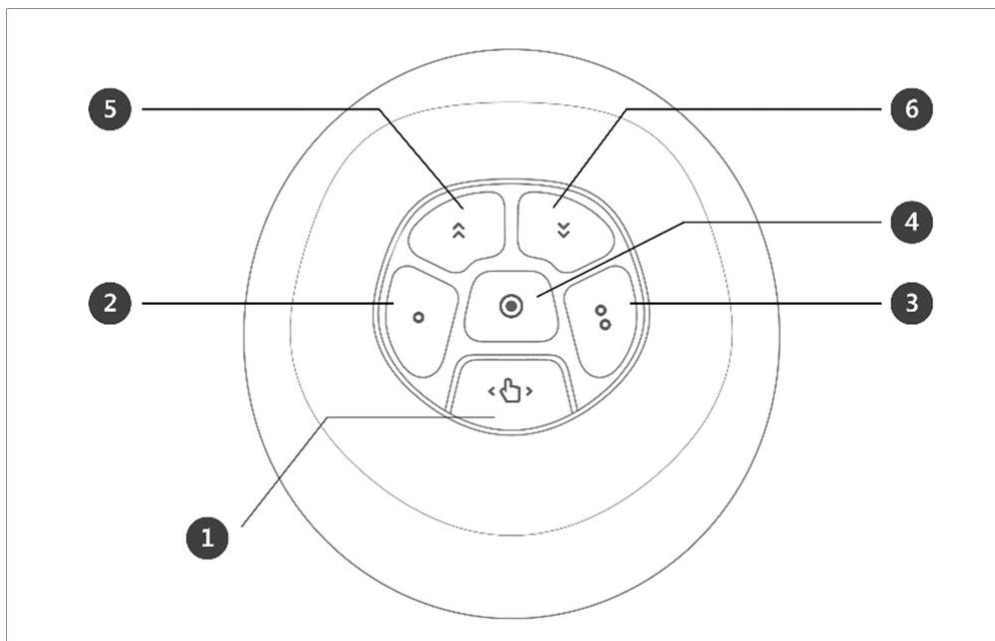

No.	Item	Description
1	Hand-Guiding Button	This button can be used to adjust or change the robot's pose.

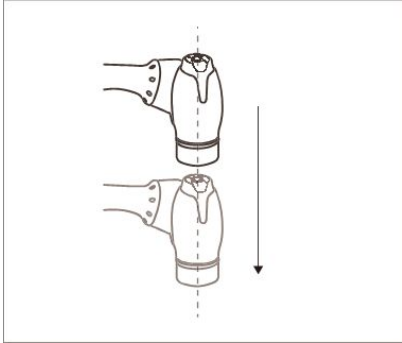
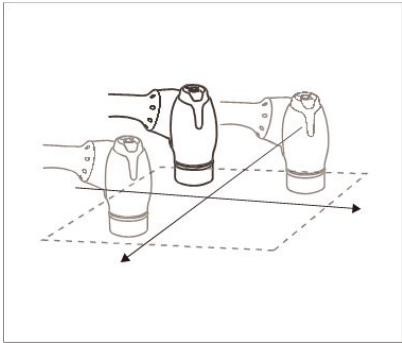
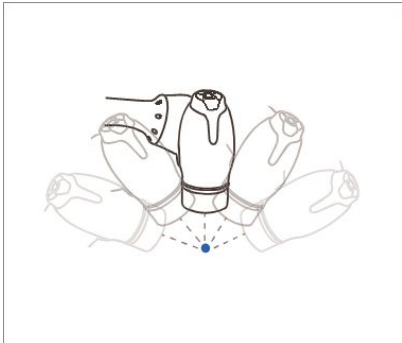
No.	Item	Description
2, 3	User Setting Button	<p>This button can modify the robot's pose by entering a pose according to a lock condition corresponding to a mode.</p> <ul style="list-style-type: none"> • Axis Lock: Changes the pose according to the Z-axis of the tool coordinates  <ul style="list-style-type: none"> • Surface Lock: Changes the pose according to the X-Y surface of the tool coordinates  <ul style="list-style-type: none"> • Point Lock: Changes the angle only from the reference point of the tool coordinates  <ul style="list-style-type: none"> • Angle Lock: Changes the position only with the current TCP angle locked

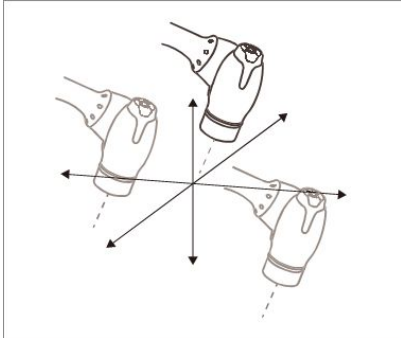
No.	Item	Description
		 <p>For more information about the settings, refer to Cockpit Setting(p. 357).</p>
4	Save Pose Button	Saves the current robot pose. For more information, refer to Skill Command Work Point Setting with Cockpit Buttons (p. 336).
5	One Line Up	Moves the Focus displayed on the screen one line up
6	One Line Down	Moves the Focus displayed on the screen one line down

i Note – Cockpit Setting Change

- **1** The hand-guiding button and **2**, **3** constraints motion button settings require 2 seconds to be modified.
- Pressing the Save Pose button on the Skill Setting screen will automatically move the focus to the next pose.
- The cancel button can only be used in the Skill Setting window that manages multi-poses.

Clamping Escape by Cockpit

Clamping Escape function can only be used when it is enabled at [Cockpit Setting](#)(p. 357).

Clamping Escape function can be enabled with **2** and **5** buttons for 5 cockpit buttons, and with **2** and **3** buttons for 6 cockpit buttons.

Clamping Escape function can be used with 2 paths on the Teach Pendant screen.

1. Entering from Servo Off status > Enters in Backdrive Handguiding Mode.

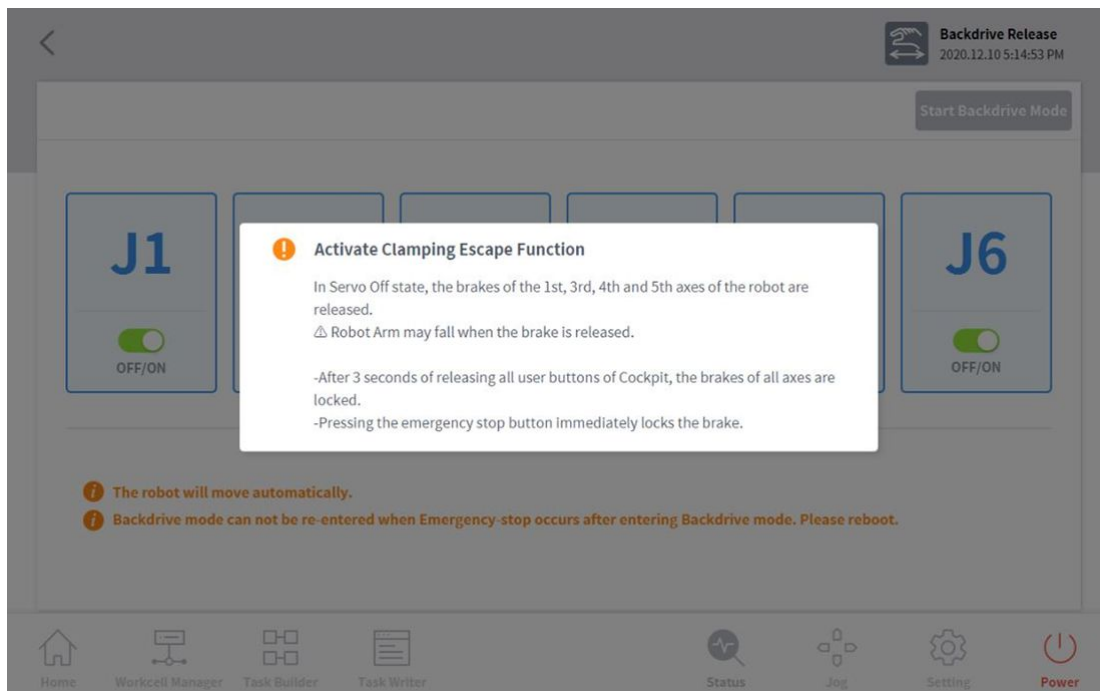

2. Entering from Interrupted status > Enters in Recovery Handguiding Mode.

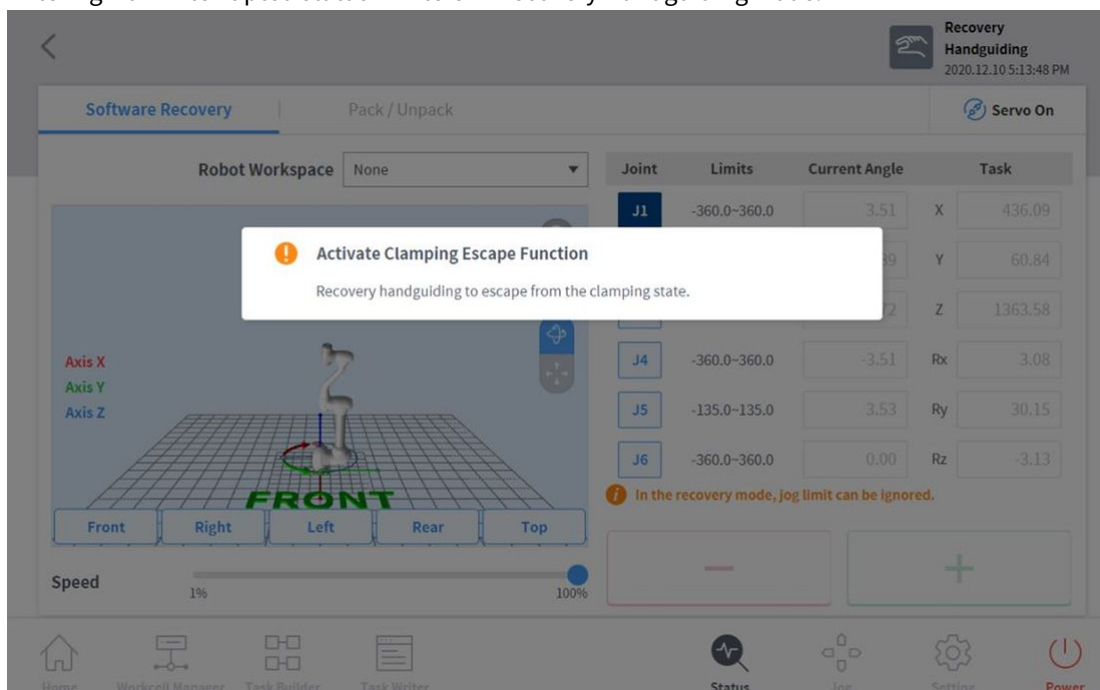

4.10 Automatic Robot Operation

This section describes how to operate the robot automatically. Robot tasks can be programmed, simulated and executed using the Task Builder or Task Writer.

For task programming samples of motion, force/compliance control, and skill, refer to [Step 4. Create Task Program](#)(p. 120).

4.10.1 Robot Teaching and Execution

In order to use the robot in the user's process, the robot space, end effector, machine tools and peripherals must be configured in the **Workcell Manager** first. When **Workcell Manager** setting is complete, create a task program using **Task Builder** or **Task Writer**, and execute it.

Task Builder displays commands recommended for the peripherals registered using the Workcell Manager, which allows the user to easily create and execute task programs. It also offers a custom code function which can load and execute task programs which have been created based on the Programming Manual.

Task Writer uses DRL (Doosan Robot Language) to create and execute programs suited for the user's process, and it also features a Custom Code function where the user can load and execute task programs created by referring to the Programming Manual.

For more information about the **Workcell Manager**, refer to [Utilizing Workcell Manager](#)(p. 252); for more information about **Task Builder**, refer to [Task Builder](#)(p. 316); and for details on **Task Writer**, refer to [Task Writer](#)(p. 344) For more information about the Doosan Robot Language, see the separate manuals.

Note

- When teaching a robot, execute teaching using conditions identical to the actual operation (tool and workpiece weight).
- When the robot is swapped, or when task execution condition (tool and workpiece weight) or the pose change, teaching deviation may occur. In such case, re-teaching is recommended.
- If the robot model is swapped, it is recommended that you create a new task program and execute teaching.

Caution

Make sure to perform a risk assessment before teaching and operating the robot. Doosan Robotics is not responsible for any consequences due to operating the robot without proper risk assessment.

4.10.2 Task Builder

After registering and configuring all Workcell items in the **Workcell Manager**, a program to execute the robot task must be created using commands or skills.

With **Task Builder**, the user can create a new task, enter skills or commands, or create tasks using templates recommended by the system. For a detailed list of skills, commands and templates, refer to the manual

provided separately. For a list of skills, commands and templates, refer to the separate Reference Manual provided.

To use Task Builder, tap  **Task Builder** on the main menu.

Task Management

Create New Task

To create a new task, follow these steps:

1. Tap **New** on the initial screen of **Task Builder**.
 - If a task is being edited, tap the  Menu button and tap **New**.
2. Select a Workcell item from the task to create and tap the > button to move the selected item to the list.
3. After selecting a Workcell item, tap **Next**.
4. Enter the name of the new task program in the **File Name** field.
5. Tap the **Confirm** button.

When a new task is created, the task edit screen is displayed. For more information on how to edit a task, refer to [Edit Task](#)(p. 320).

Template

A template is a bundle of skills that compose a work procedure used with a combination of Workcell items when a particular Workcell item is registered. It is possible to easily create a task with the settings of skills already in the template without worrying about the work process.

To create a new task using a template, follow these steps:

1. Tap the **Template** on the initial screen of **Task Builder**.
2. Select a template to use.
 - Available templates vary according to the Workcell Items registered in the **Workcell Manager**. If no Workcell Item is registered in the **Workcell Manager**, no template will be displayed.

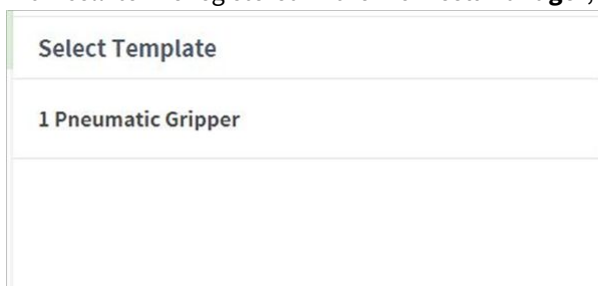

3. Enter the name of the new task program in the **File Name** field.
4. Tap the **Confirm** button.

When a new task is created using a template, the task edit screen is displayed. For more information on how to edit a task, refer to [Edit Task](#)(p. 320)

Note

Software version V2.7.3 does not support this function. The Template function will be updated and offered in again in a new software version.

Save Task

To save an edited task, tap the  Menu button and tap **Save**.

Note

If the file is not saved for the first time, a confirmation window appears. Tap the **Confirm** button to save it to an existing file.

Save Task As

To save the task as a different file, follow these steps:

1. Tap the  "Menu" button and tap the "**Save as**" button.
2. When the **Save as** window appears, enter the task name and tap the **Confirm** button.

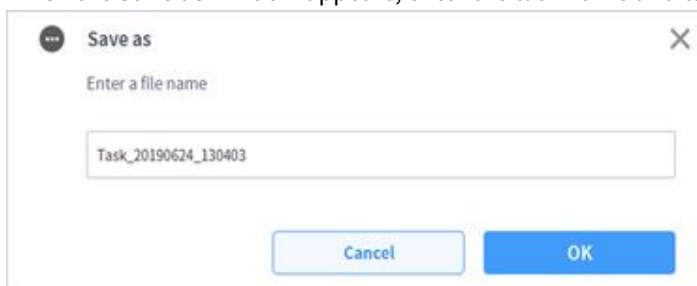

When the save is complete, the **Save Complete** window appears.

Editing Workcell Items

To view a Workcell item selected from the current task or to select or remove an additional Workcell item, please refer to the following:

1. Tap the  Menu button and press the selected Workcell item.
2. From the current task, it is possible to add or remove new Workcell items in the current task or Workcell list.

Save Task on External Storage Device (Task Builder)

To save an opened task to an external storage device, follow these steps:

1. Connect an external storage device to the USB slot.
 - Only external storage devices with FAT32 file systems can be used.
2. Tap the  Menu button and tap **Export/DRL Export**.
3. After the **Export/DRL Export** window appears, select the drive of the external storage device and tap the **Confirm** button.
4. When the **Save as** window appears, enter the task name and tap the **Confirm** button.

When the save is complete, the **Save Complete** window appears.

Note

- The file extension of the saved task file is 'tb'.
- The file extension of the saved DRL is 'drl'.

Load Saved Tasks

To load a saved task, follow these steps:

1. Tap **Saved Files** on the initial screen of the **Task Builder**.
 - If a task is being edited, tap the  Menu button and tap **Open**.
2. Select a task to open from the file list and tap the **Open** button.
3. Searches for tasks in the file list can be made using the filter function.
 - Search in latest, oldest, alphabetical order, and reverse order is possible.

Delete Saved Tasks

To delete a saved task, follow these steps:

1. Tap **Saved Files** on the initial screen of the Task Builder.
 - If a task is being edited, tap the  Menu button and tap **Open**.
2. Select a task to delete from the file list and tap the "**Delete**" button.

Import Tasks on External Storage Devices 1

To import a task saved on an external storage device, follow these steps:

1. Connect the external storage device with the task file to the USB slot.
2. Tap **Import** on the initial screen of Task Builder.
3. Tap the **Search** button.

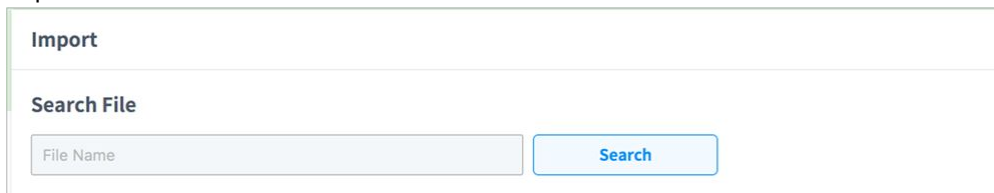

The screenshot shows a window titled "Import". Below the title is a section labeled "Search File". This section contains a text input field with the placeholder text "File Name" and a blue button labeled "Search".

4. When the **Search File** window appears, select the task to import and tap the **Confirm** button.

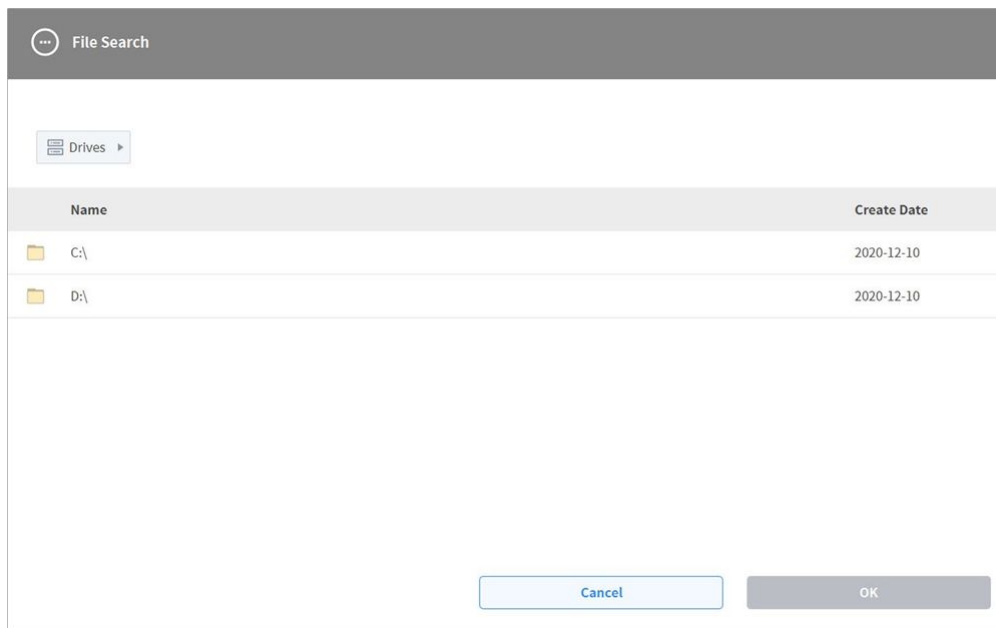

5. Tap the **Import** button on the bottom right.

When the task file is saved on an external storage device, the **Save Complete** window appears.

To load a task file saved on the system, refer to [Load Saved Tasks](#)(p. 319).

Edit Task

When a task is created, the user can add commands in the **Task List**, and when the Properties of the added command are configured, the task program can be executed. The **Task Builder** screen offers an edit function for adding/deleting/copying commands or changing the order of commands. The **Task Builder** commands consist of motion commands, flow control and other commands, and skill commands.

i Note

When attempting to enter the **Home**, **Workcell Manager** or **Task Writer** screen, a message confirming whether to save the program being edited is displayed. **Jog** and **Settings** screens are displayed as popup windows. Refer to [Robot Mode and State](#)(p. 15).

Edit Task Screen Configuration

The edit task screen of Task Builder is structured as follows:

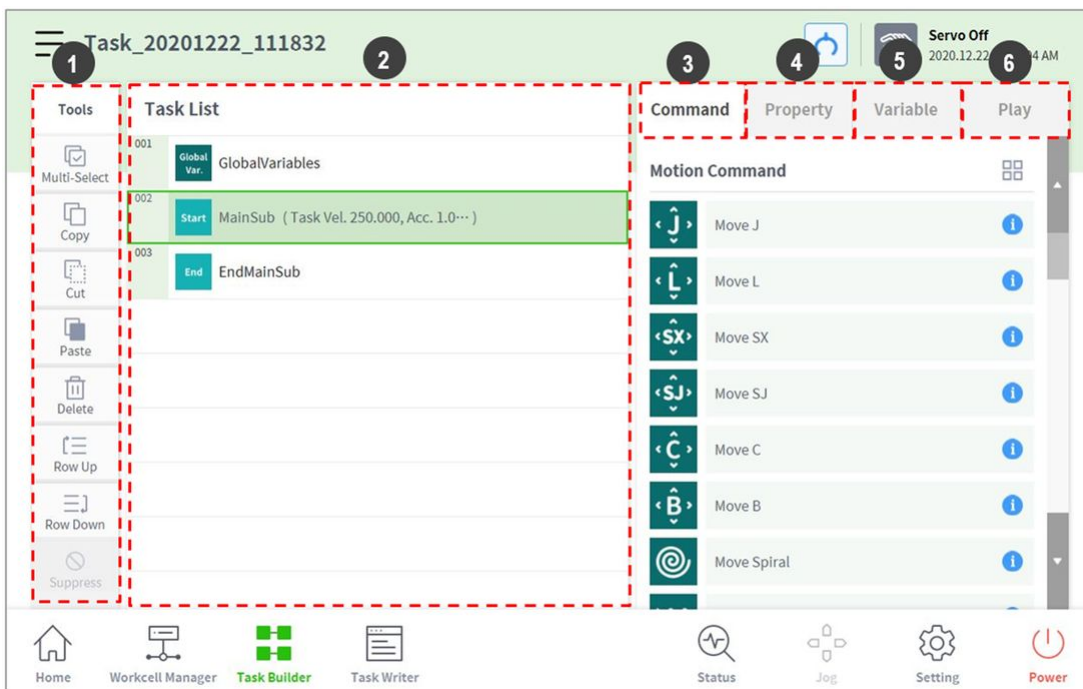

No.	Item	Description
1	Edit Command Tool (CTR)	<ul style="list-style-type: none"> • Multi Select: Select multiple commands. • Copy: Copies a command. • Cut: Cuts a command. • Paste: Pastes a copied or cut command. • Delete: Deletes a command. • Line Up: Moves a command up by a line. • Line Down: Moves a command down by a line. • Annotate: Annotates a command to exclude the corresponding command from execution during task execution.
2	Task List	Displays the task order and a list of commands added from the Command tab. When a task is created, GlobalVariables , MainSub and EndMainSub commands are added automatically.
3	Command	Displays a list of commands to add to the Task List. Selecting a command will add it to the Task List.
4	Property	Check and edit the settings of the command added to the task list.
5	Variable	Adds a system variable or tracks global and system variables used in a task.
6	Play	Executes the task currently being configured in virtual/ream mode.

Note

- **GlobalVariables:** The global variable and global pose of the task program can be entered in the **Property tab** of **GlobalVariables**, and predefined global variables and global poses can be used in the property screen of the command added in the task list.
- **MainSub** and **EndMainSub:** The command selected by the user is added to the bottom of the MainSub, and commands are executed in the order of commands located at the bottom of MainSub to commands located at the top of MainSub.
- When monitoring is performed with a variable registered in the Variable tab, the value change frequency may be too fast to display the value on the screen.
- System variables can be registered without any limit on the number starting from software version V2.8.
- If there are too many system variables registered, there may be long loading times for task execution.

Add Command

To add a command, follow these steps:

1. Select the location to add a command in the Task List.

- A command is added to the next line of the selected location.

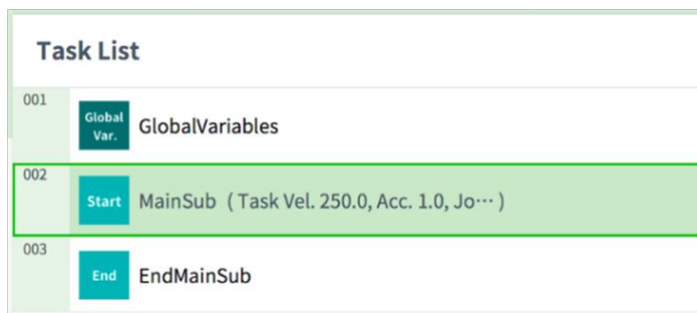

2. Select the command to add from the Command tab.

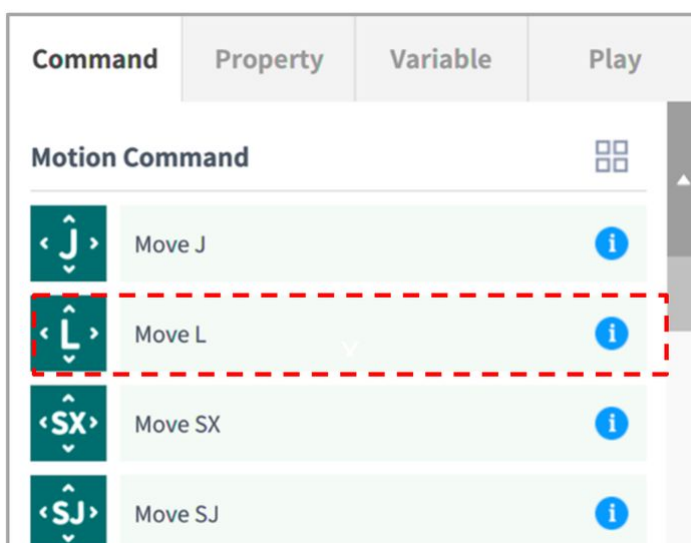

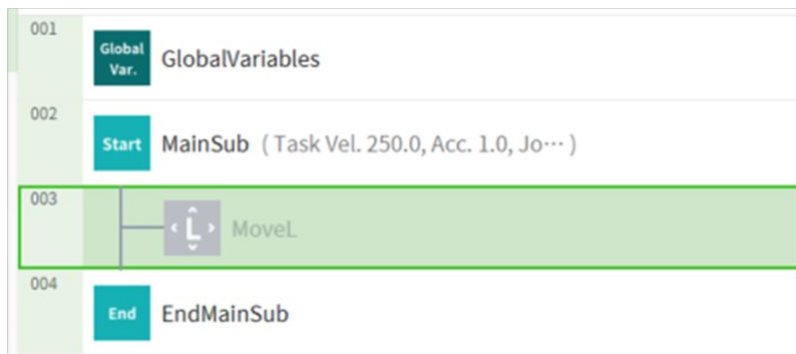

Delete Command

To delete a command, follow these steps:

1. Select a command to delete and tap the **Delete** button in the command edit tools.
2. When a confirmation window appears, tap the **Confirm** button.

Paste command

To copy/cut and paste a command to the task list, follow these steps:

1. Select command to copy or cut.
2. Tap the **Copy** or **Cut** button on the command edit tool.
3. Select the location to paste the command.
 - The copied/cut command is added to the next line of the selected location.
4. Tap the **Paste** button on the command edit tool.

Task Builder Commands

The user can create task programs using motion commands, flow control and other commands and skill commands from Task Builder. For more information about commands, refer to the manual provided separately.

Motion Command

These are commands used to adjust or change the robot's pose.

Move J	Used to move the robot to the target joint coordinates.
Move L	Used to move the robot along a line towards the target work space coordinate.
Move SX	Used to move the robot along a curved line connecting multiple via points and target points within the workspace.
Move SJ	Used to move the robot along a curved line connecting multiple via points and target points expressed as a joint coordinate.

Move C	Used to move the robot along an arc composed of a current point, via point and target point.
Move B	Used to move the robot along a line and arc connecting multiple via points and target points within the workspace.
Move Spiral	Used to move the robot along a path extending to the outer side from the center of a spiral.
Move Periodic	Used to move the robot along a path repeated periodically.
Move JX	Used to move the robot to the target workspace coordinate and joint form. This does not move along a straight line.
Stop Motion	This is used to stop task execution.

Flow Control and Other Commands

These can control the task flow through task standby, repeat, executing commands included in the task and conditions.

If	This is used to branch according to a specific condition during task execution
Else If	This is used to branch according to a specific condition during task execution.
Repeat	This is used to repeat the task command.
Continue	This is used to return to the first command of a repetition statement (Repeat).
Break	This is used to exit the repeat execution command (Repeat).
Exit	This is used to end task execution.
Sub	This is used to define a thread within the task.
Call Sub	This is used to execute the defined thread.
Thread	This is used to end thread execution.
Run Thread	This is a command to define a thread within the task.
Kill Thread	This is a command to execute a defined subtask.

Sub Task	This is used to temporarily stop task execution.
Call Sub Task	This is used to receive user input and save it in a variable during task execution.
Wait	This is used to control the Function button.
User Input	This is used to branch according to a specific condition during task execution. <ul style="list-style-type: none"> • Messages are limited to within 256 bytes. • It is recommended that the text be concise. For long text, some content is omitted with an ellipsis (...). • Formatting code such as newline (\n) or carriage return (\r) is not allowed.
Watch Smart Pendant	This is used to repeat the task command.

Force Control Command

The force of the robot can be controlled during task execution.

Compliance	This is used to control Compliance during task execution.
Force	This is used to control force during task execution.

Other Commands

There are commands that weigh the item and receive user input.

Note

- Repeated usage of specific commands regarding the screen UI may result in reduced system performance, less responsive screen UI, and abnormal operation of the program.
- It is not recommended to perform commands such as Set and Comment over 50 times per second.

Comment	This is used to save the user-designated information in a log during task execution. <ul style="list-style-type: none"> • Messages are limited to within 256 bytes. • It is recommended that the text be concise. For long text, some content is omitted with an ellipsis (...). • Formatting code such as newline (\n) or carriage return (\r) is not allowed.
Custom Code	This is used to insert and execute a DRL code during task execution.
Define	This is used to define a variable during task execution.

Popup	This is used to display a popup screen during task execution. <ul style="list-style-type: none"> • Messages are limited to within 256 bytes. • It is recommended that the text be concise. For long text, some content is omitted with an ellipsis (...). • Formatting code such as newline (\n) or carriage return (\r) is not allowed.
Set	This is used to execute various settings during task execution.
Weight Measure	This is used to measure the weight during task execution and save it in a variable.
Wait Motion	This is used to temporarily stop the robot after the previous motion command is complete.
GlobalVariables	This is used to add Global Variable.

Advanced Commands

There is a command to execute Hand-guiding.

Hand Guide	This is used to execute direct teaching during task execution.
Nudge	This is used to delay task execution until Nudge (applying force to the robot) input.

Skill Commands

This is an application command preset for using Workcell Items on the robot. A series of commands, including robot motion and I/O signals, are contained within a single skill. When a skill command is used, it is possible to easily configure jobs related to the Workcell Item without complicated programming. To use command skills, it is necessary to configure the work and related Workcell items. For more information about skill command list and configurations, refer to the manual provided separately.

Deprecated Skill Command

Skill commands can be updated due to increased usability and additional motion improvements. If a skill command is updated, the existing skill command becomes deprecated, and it cannot be added or edited. Deprecated skill commands are displayed as dimmed icons.

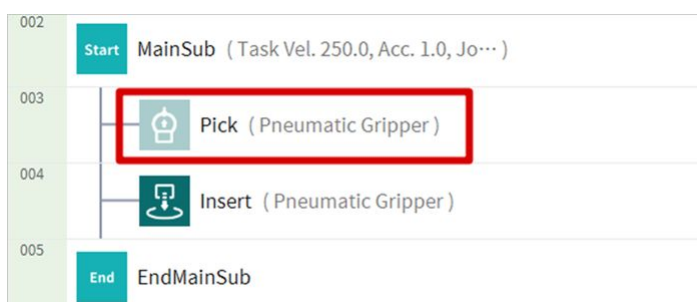

Deprecated skill commands cannot be added new, but can be used to view property information or be used in the current task program.

In the property window of a deprecated skill command, the phrase “Deprecated Item” is displayed.

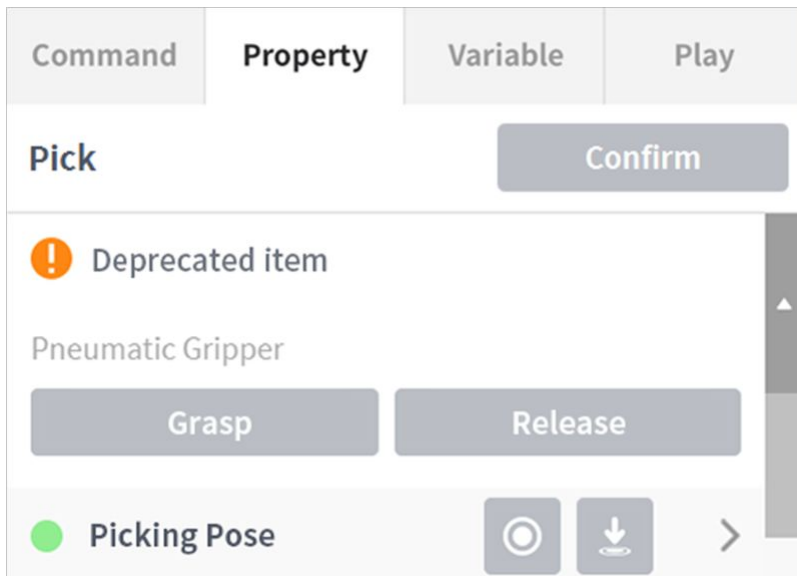

If a deprecated skill command is present, it is recommended to replace it with an updated skill command.

Setting and Applying Command Properties (Task Builder)

Tap a command list added to the task list to configure the properties of the command.

- The properties to configure vary according to the command.
- Some buttons in the command properties are enabled when related properties are entered.
- For user convenience, some properties are preconfigured with default values.
- If necessary, comments for the command can be entered.

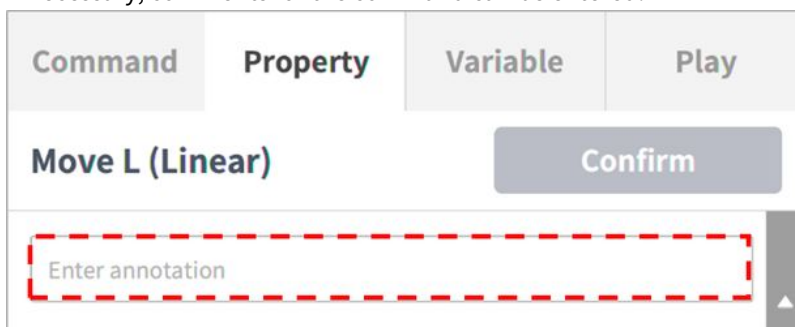

- The properties of a command are applied only after the **Confirm** button is tapped.

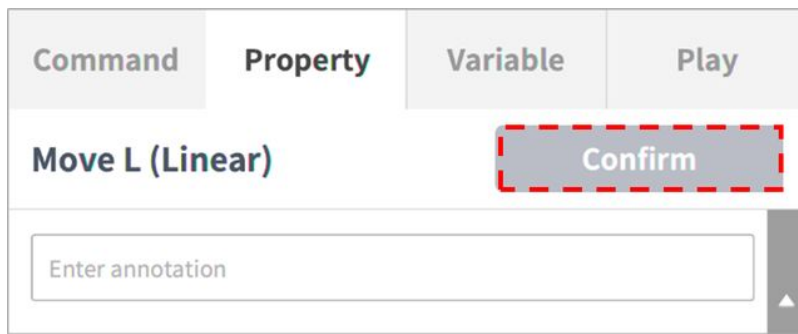

For more information about command properties, refer to the manuals provided separately.

Note

- In the case of SubTask, Sync Mode can be set. (available in V2.9 or higher)
- With Sync Mode, changes can be applied on Imported Task when saving.
- With Sync Mode, Import Task can be individually saved during exporting.
- With Sync Mode, Import Task can be individually saved during save as.

Motion Command Property Setting

Waypoint Setting

To configure the waypoint of a command, follow these steps:

1. Select the type (**Absolute, Relative**) of reference coordinate and coordinate value.



2. Either use the jog function or perform direct teaching to move the robot to the desired position.
3. Tap the **Save Pose** button to save the robot tool position.
 - If necessary, define a variable using GlobalVariables or the Define command.

Speed Setting

The default speed is the speed configured for all areas. If the speed property is set as **All Zones**, it operates the speed set in the **MainSub** property.

Tap the **Local** tab and set the speed property to **Local** to individually designate the speed to be applied to commands.

- The user can enter a speed and acceleration directly or use the slide bar to setting.
- The user can configure variables if necessary.

Caution

- When considering the maximum payload condition in the payload diagram for each model, it is recommended to set the acceleration value to the same speed or less. (Speed:Acceleration Ratio = 1:1)
- If a high acceleration is set, the robot may vibrate during acceleration/deceleration.

Note

- Beginning with V2.9 version, the acceleration unit is changed from m/s^2 to mm/s^2 .

- From V2.9 version, the maximum speed available for task setting is 4000 mm/s .

Program Link Mode Setting

Execute the following lines simultaneously with the motion to control the flow of the program.

- **Synchronized:** Program flow is put on hold until the motion ends.
- **Asynchronized:** This executes the following line simultaneously with the motion. This can be utilized for tasks such as verifying external signals or delivering output during motion.

Operating mode Sync Async

Blending Mode Setting

This is a function to move smoothly to the next target point if a specific condition is satisfied without stopping when the target point (waypoint) of the current motion command is reached.

Blending mode Duplicate Override

If the radius is set to 0, the motion blending function does not activate. So, if the robot reaches the target point of the current command, it stops and then moves to the target point of the next motion command.

Radius

0.00 mm 1000.00 mm

Overlap: When the robot reaches the set radius centering the target point of the motion command, it retains the speed of the current command and moves to the target point of the next command.

Override: When the robot reaches the set radius centering the target point of the motion command, it immediately reduces the speed of the current command and moves to the target point of the next command.

Note

If a skill is added or TCP setting performed on the command block that follows the blending radius setting or if compliance control for force control is used, an error may occur during execution. However, the blending motion is available if all options (toggle buttons) except for approach pose/retract pose are disabled when a skill is added.

Multi-Segment (Waypoint) Setting

Depending on the motion command, it may be necessary to configure two or more waypoints. Each waypoint is referred to as a segment, and adding a waypoint will add a line at the bottom of the command. The motion commands requiring two or more segments are referred to as “multi-segment motion commands.”

The following is an example of configuring a Move SJ command.

1. Tap **Add Pose** in command properties.

- Segment 1 is added to the bottom line of Move SJ command.

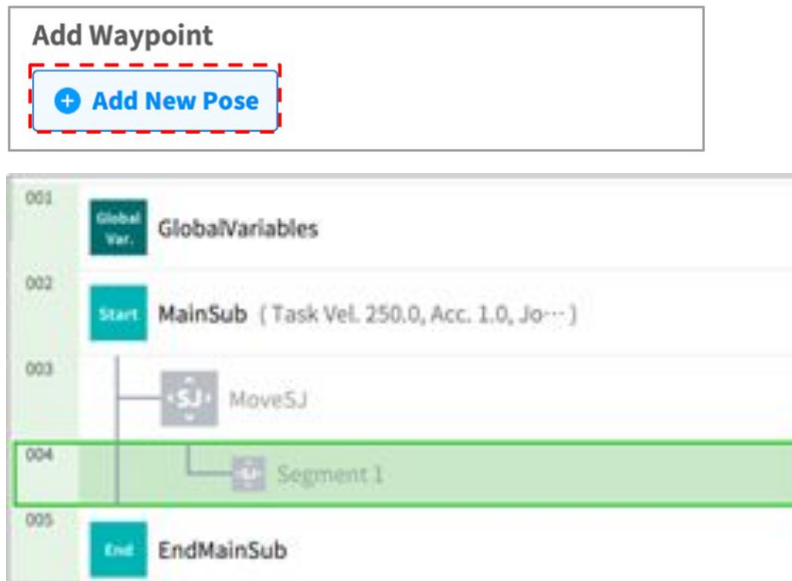

2. Either use the jog function or perform direct teaching to move the tool to the desired position.

3. Tap the **Save Pose** button in segment properties to save the robot tool position.

4. Repeat steps 1-3 to add segments.

Skill Command Property Setting

Understanding Basic Principles of Skill Commands

Skill commands are based on a few operation patterns.

For a robot to begin operation, the weight and tool center point (TCP) of the tool equipped on the robot must be configured, and the basic operational pattern of the skill commands must have an approach pose and retract pose that are perpendicular to the reference pose.

TCP Setting: Using an End Effector skill command will automatically change the TCP offset setting. The End Effector skill command execution stage includes an offset setting suited for the TCP of the End Effector. If the TCP offset changes, the Blending Motion function, which smoothly connects the previous motion command, cannot be used.

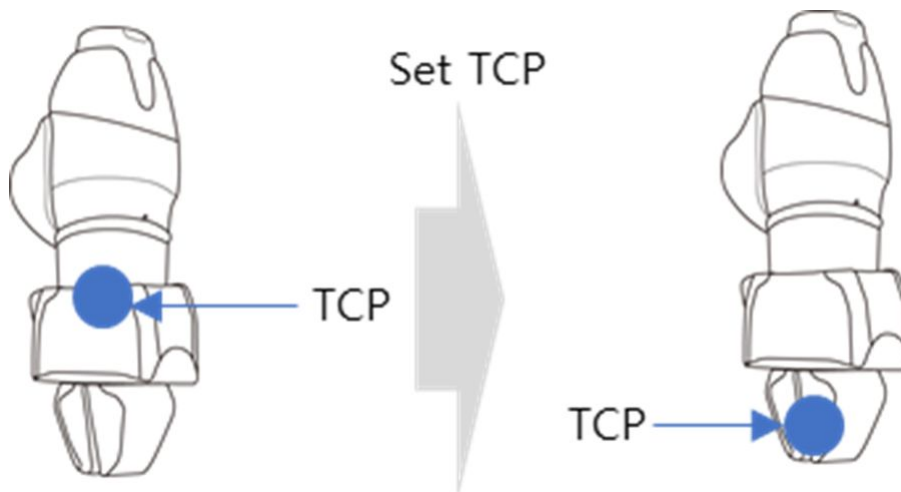

Move to Approach Pose: This is a point available to move to the Approach Pose. It is set in the Z direction from the Approach Pose, and a different direction can also be selected. The Approach Distance entered is automatically calculated for the Action Pose and moves to the corresponding point.

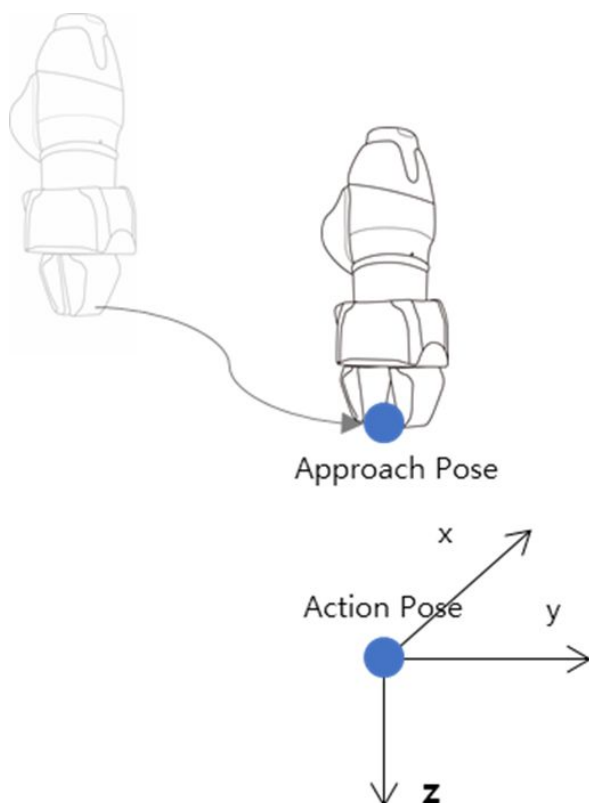

Move to Reference Pose: This is the point on the workpiece where the End Effector performs work. To set detailed coordinates other than the velocity and acceleration for the reference pose, press the  button on the right side of the reference pose. However, using the relative coordinates tab while setting the detailed motion

can cause a malfunction during skill execution, so make sure to use the absolute coordinates for reference point teaching.

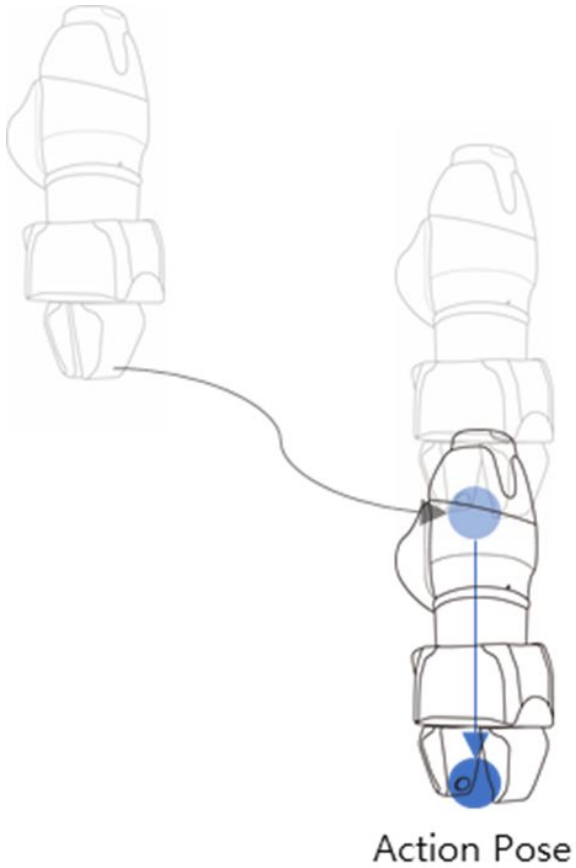

Move to Retract Pose: This is the point to pick up the workpiece and move it safely to another point. It is the Z direction from the Approach Pose, and a different direction can also be selected. The Retract Distance entered is automatically calculated for the Action Pose and moves to the corresponding point.

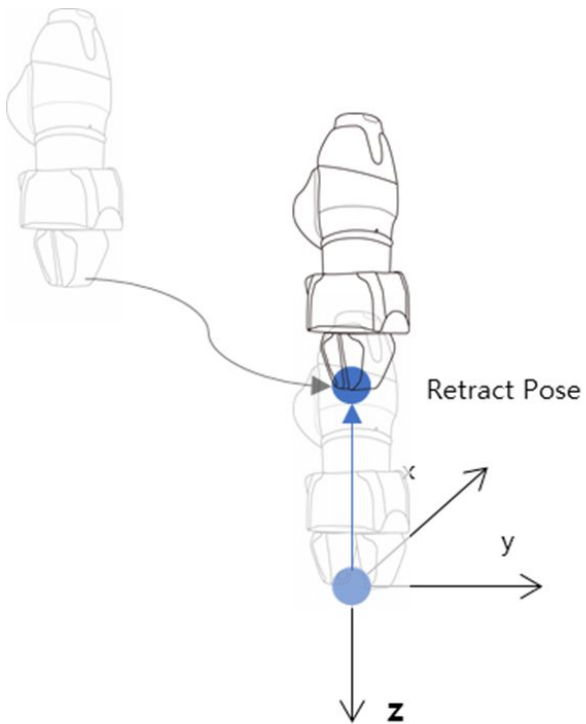

Move to Start Pose: If the End Effector execution target does not end with a single motion, there may be an intermediate point and an end point, and the Action Start Pose is the point where the work starts. (i.e. Door_OpenClose Skill - Start Pose)

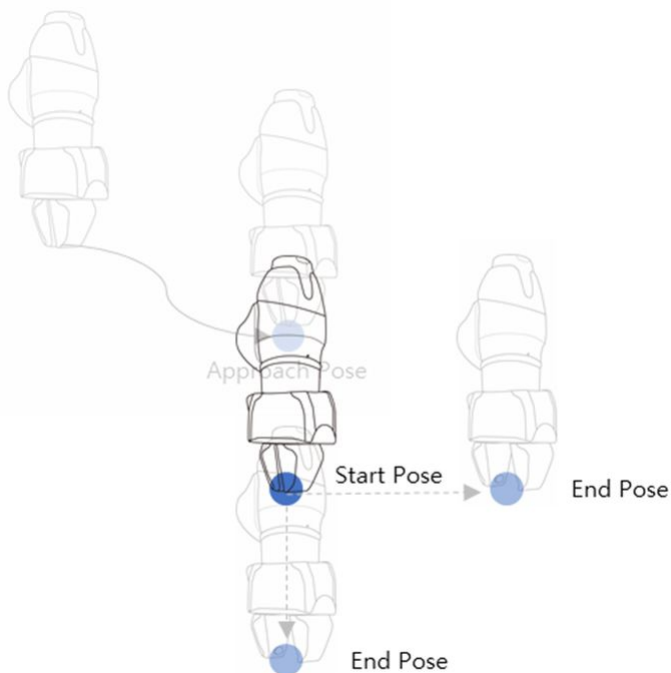

Move to End Pose: If the End Effector execution target does not end with a single motion, there may be an intermediate point and an end point, and the Action End Pose is the point where the work ends. (i.e. Door_OpenClose Skill – End Pose)

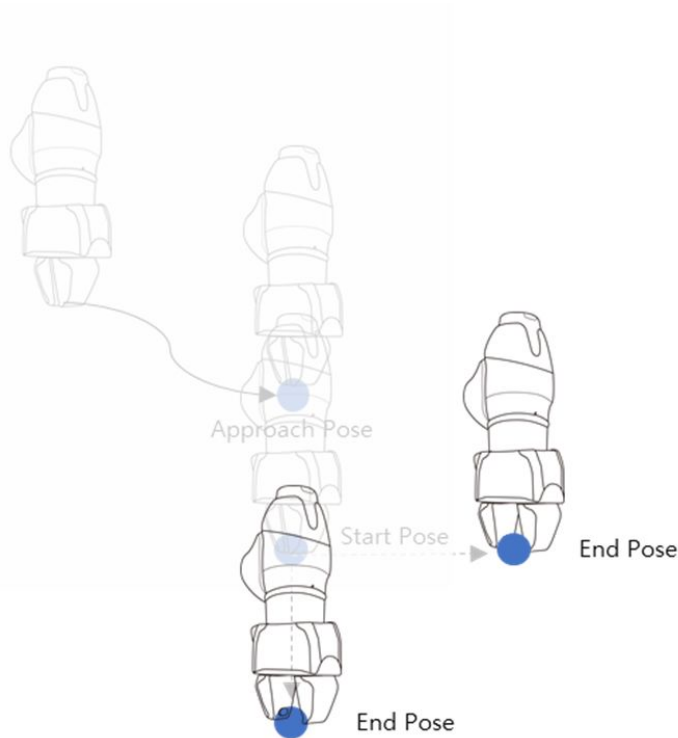

Compliance Control and Contact Check

With the Compliance Control and Contact Sensing functions, which is the unique force control technology of Doosan Robotics, it is possible to easily perform teaching without repeated operation for accurate point designation since it allows position deviation within a tolerance range between the workpiece and surrounding items during robot operation.

Compliance Control: If force is applied during Approach, Action and Retract, it allows deviation from the set position with some level of buffering, like a spring.

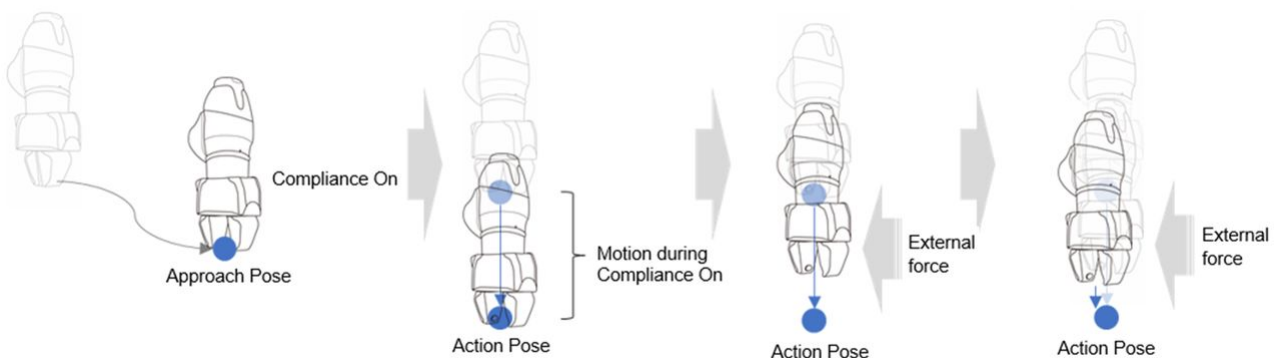

Contact Check: Based on the **Contact Force** and **Contact Determination Range** values entered, the function detects contact with the target, stops at a corresponding position and activates the gripper to grab the target.

- This function must be used with Compliance Control Function. If **Force** is entered and Compliance Control is not enabled, an error occurs.
- Contact is a function that detects contact with an external force, so the sensitivity of Collision Detection must be set at low levels or Collision Detection must be disabled.
- Be careful when using this function, as excessive force can be generated when contacting the external environment if the Compliance Control option stiffness (i.e., Z-direction) value is too large or the work speed is too high. (It is necessary to make adjustments according to the situation by lowering the stiffness value if the work speed is too high or by increasing the stiffness if work speed is too low.)

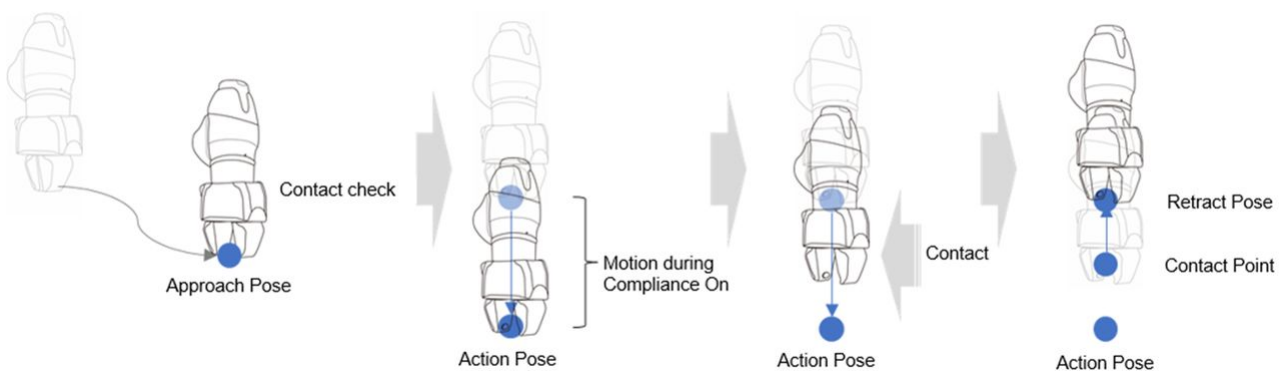

Skill Command Work Point Setting with Cockpit Buttons

Cockpit buttons can be used to configure the action pose.

For example, with the Pick skill command:

1. Add a skill command from **Task Builder** and tap the added skill command.
2. Perform direct teaching to the skill's action pose to move the robot.
3. Press the Save Pose button on the cockpit.



Note

Save Cockpit Pose is available from the Task Builder and Task Writer.

Execute Task Program

Provides descriptions of the play screen of Task Builder and screen configuration. The play screen offers the function to priorly check robot motion by executing the task virtually.



Note

- Before closing the simulator/robot, make sure to press the "stop" button () to stop the motion program.
- Moving to the **Play** tab disengages manual mode and engages Auto mode.



- When entering manual mode on the **Play** tab, go to the **Command** tab or **Property** tab before moving to another menu.

Virtual mode screen

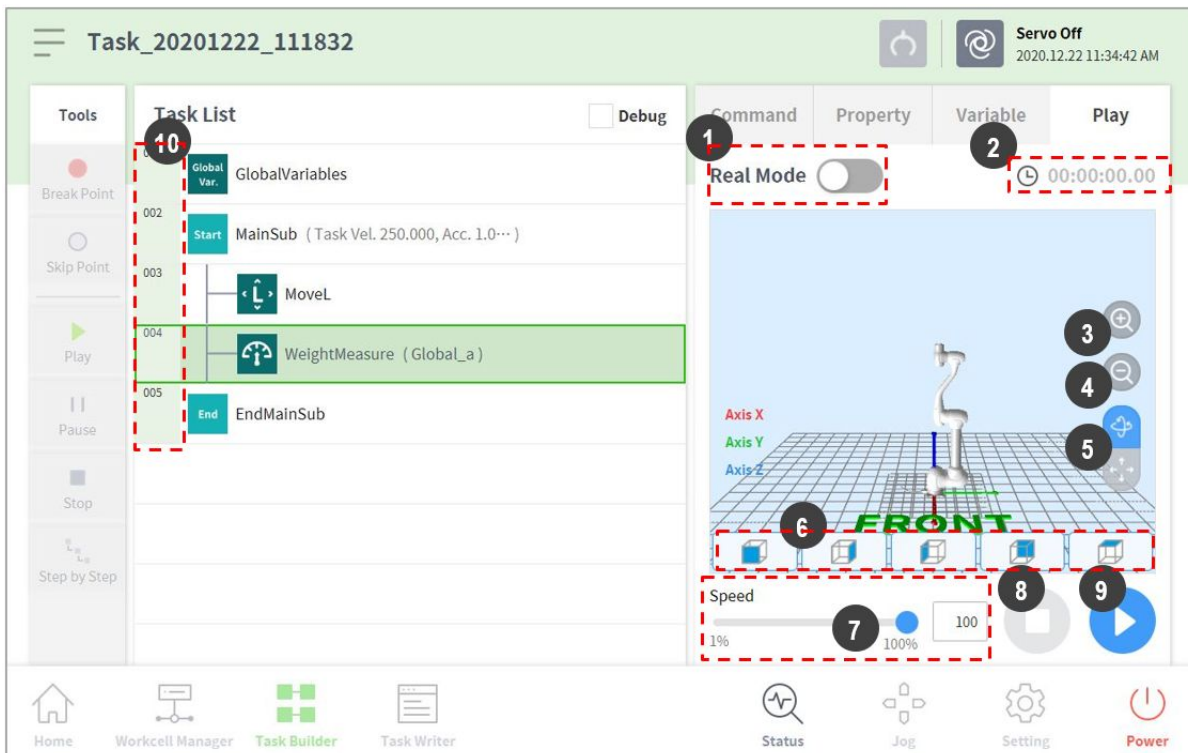
The virtual mode screen of Task Builder is structured as follows:



No.	Item	Description
1	Real mode ()	Sets the robot test play mode. <ul style="list-style-type: none"> • Real mode: Operates an actual robot to test the task in the task list. • Virtual mode: Uses a simulator screen to test the task in the task list.
2	Total time	Displays the total time elapsed after the task execution.
3	Simulator Zoom-in button	Zooms into the simulated robot model.
4	Simulator Zoom-out button	Zooms out from the simulated robot model.

5	Rotate and pan button	Rotate button  : Rotates the simulation screen with the robot base as a central axis. Pan button  : Moves the simulation screen horizontally and vertically.
6	Viewpoint button	Sets viewpoints with the robot model as the control point.
7	Speed slider	It sets the speed of the robot in a real or a virtual mode.
8	Stop button	It stops the current task.
9	Execute/pause toggle button	It executes or pauses the work in the task list.
10	Time	It displays the time spent on the corresponding command/skill.

Real Mode Screen: Information Message Tab

The real mode screen end effector information tab of Task Builder is structured as the following.

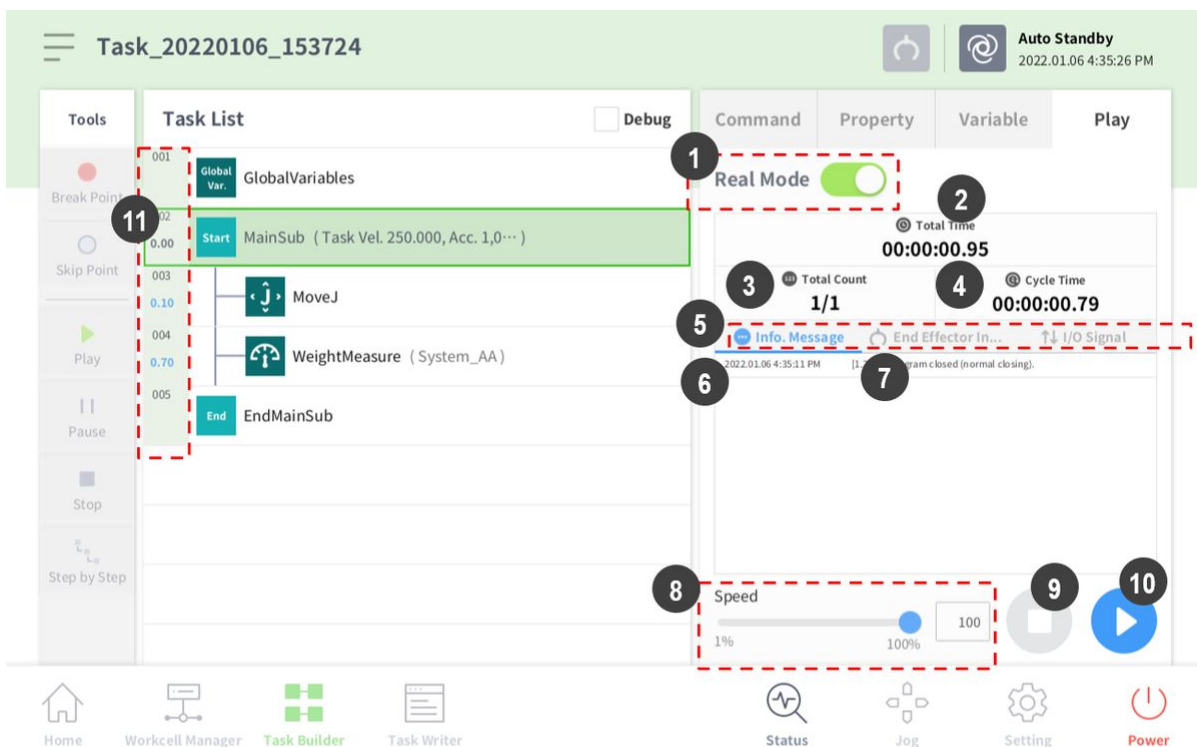

The screenshot shows the Real Mode Screen in Task Builder. The interface is divided into several sections:

- Task List (Left):** A list of tasks with a 'Debug' checkbox. The tasks are:
 - 001 GlobalVar: GlobalVariables (11)
 - 002 Start MainSub (Task Vel. 250.000, Acc. 1,0...)
 - 003 MoveJ
 - 004 WeightMeasure (System_AA)
 - 005 End EndMainSub
- Information Panel (Right):**
 - 1 Real Mode:** A toggle switch that is currently turned on.
 - 2 Total Time:** 00:00:00.95
 - 3 Total Count:** 1/1
 - 4 Cycle Time:** 00:00:00.79
 - 5 Info. Message:** A message box showing the timestamp **6** 2022.01.06 4:35:11 PM and the message **7** Program closed (normal closing.).
- Speed Control (Bottom):**
 - 8 Speed:** A slider set to 100%.
 - 9 Play:** A play button.
 - 10 Power:** A power button.

	Item	Description
1	Real Mode	It sets the robot test play mode. <ul style="list-style-type: none"> • Real: It operates an actual robot to test the task in the task list. • Virtual: It uses a simulator screen to test the task in the task list.
2	Total time	It displays the total time elapsed after the task execution.
3	Total count	It displays the total number of task executions.
4	Average execution time	It displays the average time spent to execute one cycle of the task in the task list.
5	Information Screen Shift Tab	It shifts between the robot information message screen, End Effector information screen and I/O information screen. <ul style="list-style-type: none"> • Information Message Tab: It displays the information messages generated during execution. • End Effector Information Tab: It displays the robot tool center point, tool weight and collision and force information. • I/O Information Tab: It displays the I/O information of the controller and flange.
6	Information Message Time Area	It displays the time information of the displayed information message.
7	Information Message Area	Displays the information message.
8	Speed slider	It sets the speed of the robot in a real or a virtual mode.
9	Stop button	It stops the current task.
10	Play/Pause Toggle Button	It executes or pauses the work in the task list.
11	Time	It displays the time spent on the corresponding command/skill.

[Real Mode Screen: End Effector Information tab](#)

The real mode screen end effector information tab of Task Builder is structured as follows:

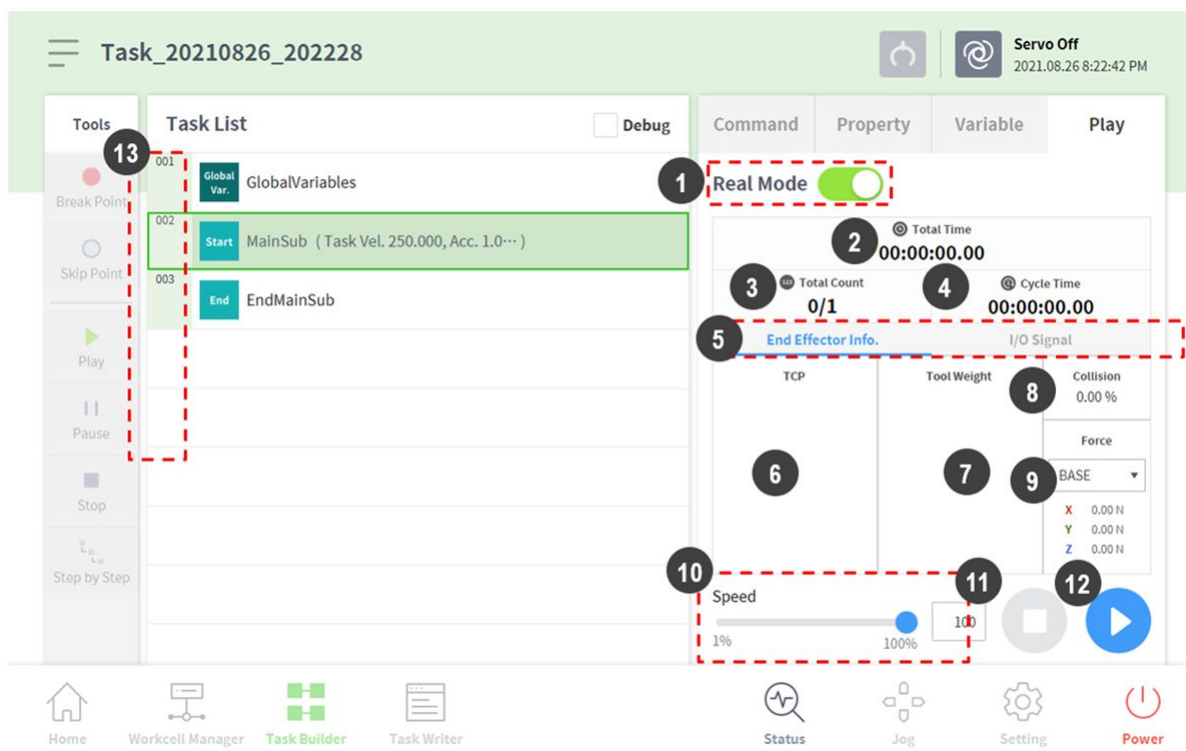

No.	Item	Description
1	Real Mode ()	Sets the robot test play mode. <ul style="list-style-type: none"> • Real mode: Operates an actual robot to test the task in the task list. • Virtual mode: Uses a simulator screen to test the task in the task list.
2	Total time	Displays the total time elapsed after the task execution.
3	Total count	Displays the total number of task executions.
4	Average execution time	Displays the average time spent to execute one cycle of the task in the task list.
5	Information Screen Shift Tab	You can switch between the robot information message screen, End-Effector information screen, and input/output information screen. <ul style="list-style-type: none"> • Information Messages tab: Displays information messages that occur during playback. • End Effector Information Tab: Displays the center point of the robot tool, the tool weight and the collision and force information. • I/O Information Tab: Displays the I/O information of the controller and the flange.

6	Tool center point information area	Displays the tool center point information configured through the tool center point and weight configuration functions of the set TCP command or the jog.
7	Tool weight information	Displays the tool weight information configured through the tool center point and weight configuration functions of the set TCP command or the jog.
8	Collision information area	Displays the collision sensitivity value set for the area where the robot is currently positioned.
9	Force information area	It displays the force information occurring in the Base, World, User, and Reference coordinate systems. The Reference coordinate system displays force based on the coordinate system information applied to the robot.
10	Speed slider	It sets the speed of the robot in a real or a virtual mode.
11	Stop button	It stops the current task.
12	Execute/pause toggle button	It executes or pauses the work in the task list.
13	Time	It displays the time spent on the corresponding command/skill.

 **Caution**

- Before executing a task, execute the task in virtual mode to check whether the task operates as intended.
- It is recommended to test the robot program by designating temporary waypoints outside another machine's work space. Doosan Robotics is not responsible for damages that occur due to programming error or robot malfunctioning, as well as damage to the equipment.
- The emergency stop button is located on the teach pendant. In an emergency situation, press the emergency stop button to stop the robot.

[Real Mode Screen: I/O Information Tab](#)

The real mode play screen end I/O information tab of Task Builder is structured as follows:

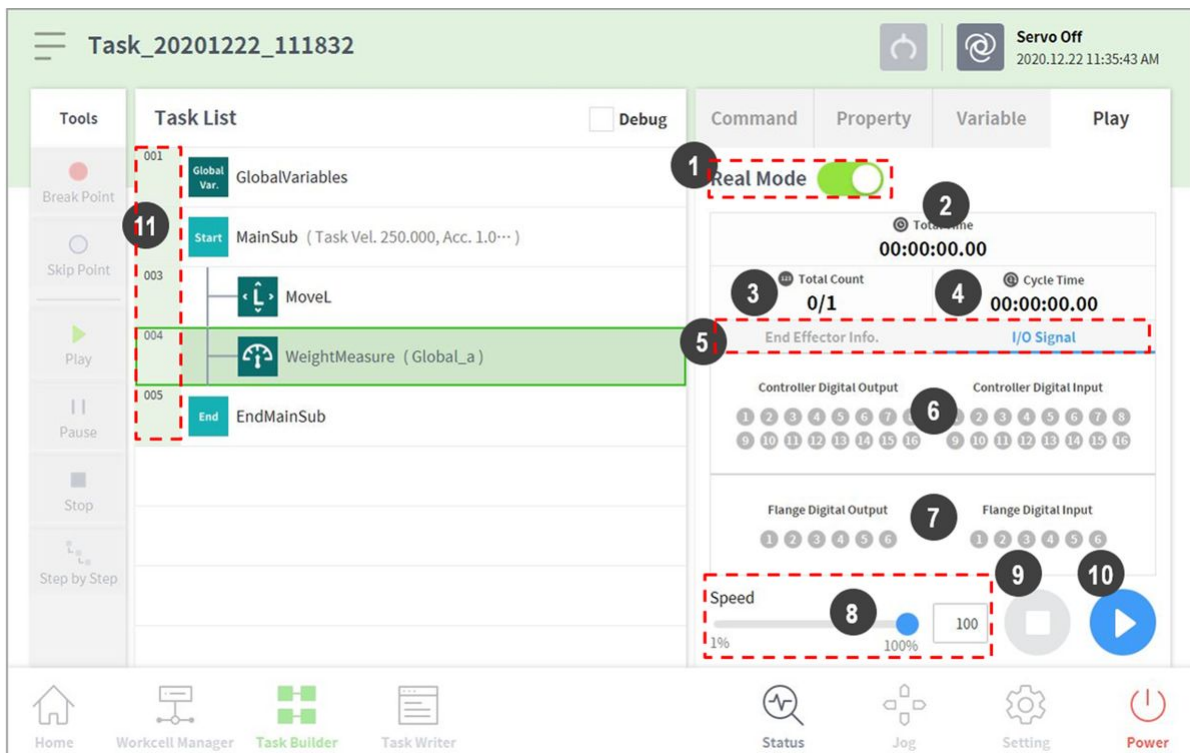

No	Item	Description
1	Real mode ()	Sets the robot test play mode. <ul style="list-style-type: none"> • Real mode: Operates an actual robot to test the task in the task list. • Virtual mode: Uses a simulator screen to test the task in the task list.
2	Total time	Displays the total time elapsed after the task execution.
3	Total count	Displays the total number of task executions.
4	Average execution time	Displays the average time spent to execute one cycle of the task in the task list.
5	Information Screen Shift Tab	You can switch between the robot information message screen, End-Effector information screen, and input/output information screen. <ul style="list-style-type: none"> • Information Messages tab: Displays information messages that occur during playback. • End Effector Information Tab: Displays the center point of the robot tool, the tool weight and the collision and force information. • I/O Information Tab: Displays the I/O information of the controller and the flange.



6	Controller digital I/O signal	Displays the controller digital I/O signals of the current task. <ul style="list-style-type: none"> • If the digital signal is a high signal, the icon is displayed in sky blue. • If the digital signal is a low signal, the icon is displayed in gray.
7	Flange digital I/O signal	Displays the flange digital I/O signals of the current task. <ul style="list-style-type: none"> • If the digital signal is a high signal, the icon is displayed in sky blue. • If the digital signal is a low signal, the icon is displayed in gray.
8	Speed slider	It sets the speed of the robot in a real or a virtual mode.
9	Stop button	It stops the current task.
10	Execute/pause toggle button	It executes or pauses the work in the task list.
11	Time	It displays the time spent on the corresponding command/skill.

Execute Task

It is possible to test the task being created by executing it. To execute a task, follow these steps:

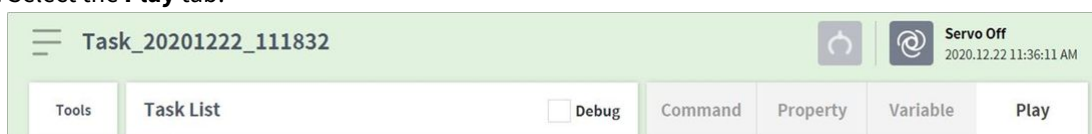
1. Select the **Play** tab.



2. Tap the **Real Mode** () button.
3. Drag the speed slider to set the robot speed.
4. Press  to execute the task.
 - Pause (): Pauses the task currently being executed.
 - Stop (): Stops the task currently being executed.

Note

- If Real mode is off, execution is made only in virtual mode where the robot is only operated in the simulator.
- When Real mode is turned on, a status display showing the I/O status appears.
- When executing a task program in virtual mode, it is only executed once regardless of the setting, and diverging through I/O signal within the task does not execute properly.
- Tool center position and tool weight information on the play information screen are only displayed properly when the Set TCP command is executed or the tool center position and weight of the jog are set.
- Commands that had issues occur during program execution are highlighted with orange.

4.10.3 Task Writer

Task Writer is intended for advanced users familiar with program coding. It allows complex motions that cannot be executed with basic commands to be created using DRL (Doosan Robot Language) and Custom Code, which allows the user to load and execute programs created or saved on an external storage device.

Simplified, convenient functions are only available in **Task Builder**, and advanced custom code functions are only available with the **Task Writer**.

Tap the Task Writer () button to go to the Task Writer screen.

Task Management

Create New Task

To create a new task, follow these steps:

1. Tap **"New"** on the main Task Writer screen.
 - If a task is being edited, tap the  Menu button and tap **New**.
2. Enter the name of the new task program in the **File Name** field.
3. Tap the **Confirm** button.

When a new task is created, the task edit screen is displayed. For more information on how to edit a task, refer to [\(2.12.2-en_US\) Edit Task Program\(p. 347\)](#).

Save Task

To save an edited task, tap the  Menu button and tap **Save**.



Note

If the file is not saved for the first time, a confirmation window appears. Tap the **Confirm** button to save it to an existing file.

Save Task As

To save a task as different file, follow these steps:

1. Tap the  Menu button and tap the **Save as** button.
2. When the **Save as** window appears, enter the task name and tap the **Confirm** button.

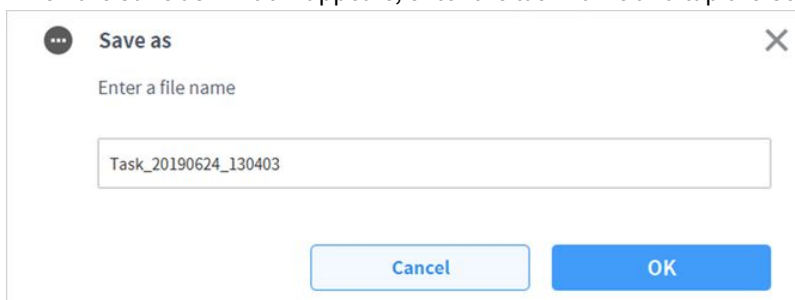

When the save is complete, the **Save Complete** window appears.

Save Task on External Storage Device (Task Writer)

To save an opened task as on an external storage device, follow these steps:

1. Connect an external storage device to the USB slot.
 - Only external storage devices with FAT32 file systems can be used.
2. Tap the  Menu button and tap **Export/DRL Export**.
3. After the **Export/DRL Export** window appears, select the drive of the external storage device and tap the **Confirm** button.
4. When the **Save as** window appears, enter the task name and tap the **Confirm** button.

When the save is complete, the **Save Complete** window appears.

Note

- The file extension of the saved task file is 'tw'.
- The file extension of the saved DRL is 'drl'.

Load Saved Tasks

To load a saved task, follow these steps:

1. Tap **Saved Files** on the main screen of **Task Writer**.
 - If a task is being edited, tap the  Menu button and tap **Open**.
2. Select a task to open from the file list and tap the **Open** button.
3. Searches for tasks in the file list can be made using the filter function.
 - Search in latest, oldest, alphabetical order, and reverse order is possible.

Note

Even if the model where the task was created is different, the task can be loaded on any M-Series model. However, the M-Series and A-Series are not mutually compatible.

Delete Saved Tasks

To delete a saved task, follow these steps:

1. Tap **Saved Files** on the main screen of **Task Writer**.
 - If a task is being edited, tap the  Menu button and tap **Open**.
2. Select a task to delete from the file list and tap the **Delete** button.

Import Tasks on External Storage Devices

To import a task saved on an external storage device, follow these steps:

1. Connect the external storage device with the task file to the USB slot.
2. Tap the **Import** on the **Task Writer** initial screen.
3. Tap the **Search** button.

4. When the **Search File** window appears, select the task to import and tap the **Confirm** button.

Name	Create Date
C:\	2020-12-10
D:\	2020-12-10

5. Tap the **Import** button on the bottom right.

When the task file is saved on an external storage device, the **Save Complete** window appears.

To load a task file saved on the system, refer to [\(2.12.2-en_US\) Load Saved Tasks](#)(p. 353).

Export Task to External Storage Device

To export a task to an external storage device, follow these steps:

1. Connect the external storage device with the task file to the USB slot.
2. Tap the **Export** on the **Task Writer** initial screen.
3. The export popup window appears. Select the external drive to export the task and tap the **"Confirm"** button.

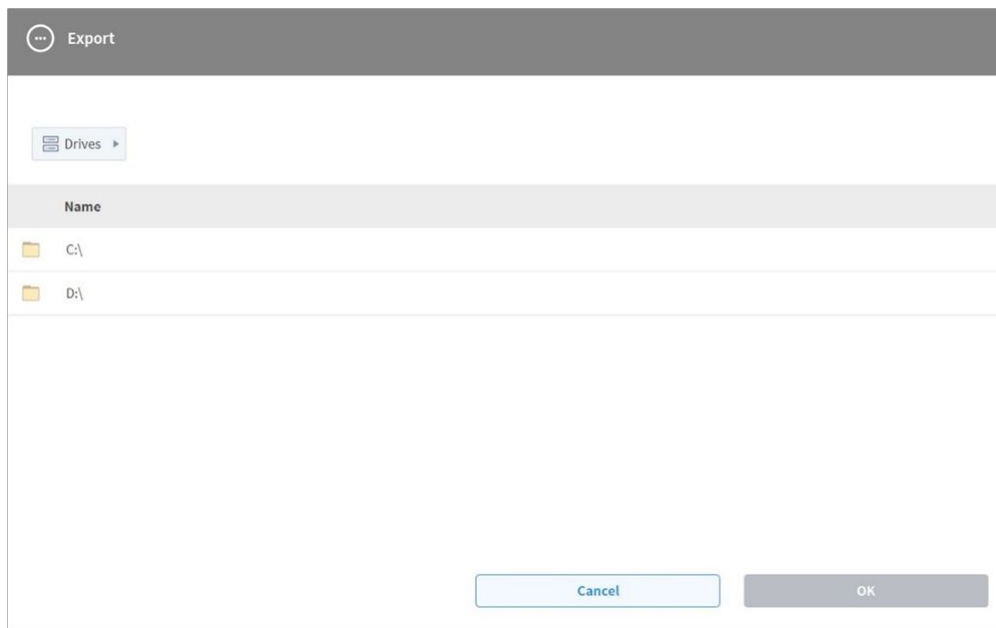

4. The Save As popup window appears. Enter the task name in the popup window and tap the **"Confirm"** button.

Edit Task Program

The edit screen of Task Writer is identical to that of the edit screen of Task Builder, and the editing features are also identical.

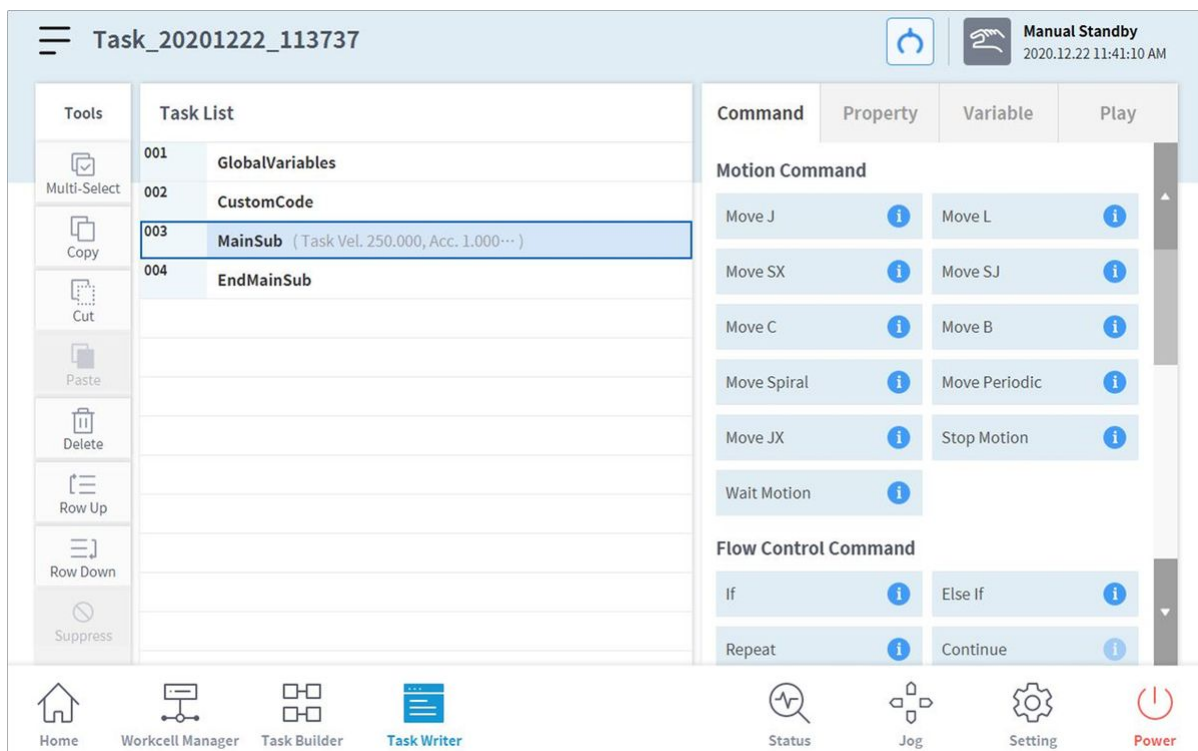

For more information about the edit task program, refer to [\(2.12.2-en_US\) Edit Task](#)(p. 320).

Note

- **GlobalVariables:** The global variable and global pose of the task program can be entered in the **Property** tab of **GlobalVariables**, and predefined global variables and global poses can be used in the property screen of the command added in the task list. 10 all-area variables and all-area poses can be added to each GlobalVariables command.
- **CustomCode:** The user can enter DRL Codes or load predefined programs saved in an external storage device.
- **MainSub** and **EndMainSub:** The command selected by the user is added to the bottom of the **MainSub**, and commands are executed in the order of commands located at the bottom of **MainSub** to commands located at the top of **MainSub**.
- **Thread:** Jobs to be performed simultaneously with **MainSub** can be added as a **Thread**, and when a **Thread** is added, a command can be added below the **Thread**. Motion commands cannot be added to a **Thread**.
- The **Line Monitoring option** under Thread command > Property screen is used to allow/disallow focus transfer to commands inside the thread block upon program execution.

Task Writer Command

The commands available in the Task Writer are **Motion Commands, Flow Control and Other Commands,** and **Advanced Commands.**

Motion Command

These are commands used to adjust or change the robot's pose.

Move J	Used to move the robot to the target joint coordinates.
Move L	Used to move the robot along a line towards the target work space coordinate.
Move SX	Used to move the robot along a curved line connecting multiple via points and target points within the workspace.
Move SJ	Used to move the robot along a curved line connecting multiple via points and target points expressed as a joint coordinate.
Move C	Used to move the robot along an arc composed of a current point, via point and target point.
Move B	Used to move the robot along a line and arc connecting multiple via points and target points within the workspace.
Move Spiral	Used to move the robot along a path extending to the outer side from the center of a spiral.

Move Periodic	Used to move the robot along a path repeated periodically.
Move JX	Used to move the robot to the target workspace coordinate and joint form. This does not move along a straight line.
Stop Motion	This is used to stop task execution.

Flow Control and Other Commands

These can control the task flow through task standby, repeat, executing commands included in the task and conditions.

If	This is used to branch according to a specific condition during task execution.
Else If	This is used to branch according to a specific condition during task execution.
Repeat	This is used to repeat the task command.
Continue	This is used to return to the first command of a repetition statement (Repeat).
Break	This is used to exit the repeat execution command (Repeat).
Exit	This is used to end task execution.
Sub	This is used to define a subroutine within the task.
Call Sub	This is used to execute the defined subroutine.
Thread	This is used to define a thread within the task.
Run Thread	This is used to execute the defined thread.
Kill Thread	This is used to end thread execution.
Sub Task	This is a command to define a thread within the task.
Call Sub Task	This is a command to execute a defined subtask.
Wait	This is used to temporarily stop task execution.

User Input	This is used to receive user input and save it in a variable during task execution. <ul style="list-style-type: none"> • Messages are limited to within 256 bytes. • It is recommended that the text be concise. For long text, some content is omitted with an ellipsis (...). • Formatting code such as newline (\n) or carriage return (\r) is not allowed.
Watch Smart Pendant	This is used to control the Function button.

Force Control Command

The force of the robot can be controlled during task execution.

Compliance	This is used to control Compliance during task execution.
Force	This is used to control force during task execution.

Other Commands

There are commands that weigh the item and receive user input.

Note

- Repeated usage of specific commands regarding the screen UI may result in reduced system performance, less responsive screen UI, and abnormal operation of the program.
- It is not recommended to perform commands such as Set and Comment over 50 times per second.

Comment	This is used to save the user-designated information in a log during task execution. <ul style="list-style-type: none"> • Messages are limited to within 256 bytes. • It is recommended that the text be concise. For long text, some content is omitted with an ellipsis (...). • Formatting code such as newline (\n) or carriage return (\r) is not allowed.
Custom Code	This is used to insert and execute a DRL code during task execution.
Define	This is used to define a variable during task execution.
Popup	This is used to display a popup screen during task execution. <ul style="list-style-type: none"> • Messages are limited to within 256 bytes. • It is recommended that the text be concise. For long text, some content is omitted with an ellipsis (...). • Formatting code such as newline (\n) or carriage return (\r) is not allowed.
Set	This is used to execute various settings during task execution.

Weight Measure	This is used to measure the weight during task execution and save it in a variable.
Wait Motion	This is used to temporarily stop the robot after the previous motion command is complete.
GlobalVariables	This is used to add a Global Variable.

Advanced Commands

There is a command to execute Hand-guiding.

Hand Guide	This is used to execute direct teaching during task execution.
Nudge	This is used to delay task execution until Nudge (applying force to the robot) input.

Setting and Applying Command Properties

Configuring and applying the commands in **Task Writer** are identical to those of **Task Builder**([2.12.2-en_US Setting and Applying Command Properties \(Task Builder\)](#)(p. 327)).

Execute Task Program

The execution of task programs in **Task Writer** is identical to that of **Task Builder**([2.12.2-en_US Execute Task Program](#)(p. 336)).

Debug Screen

The debug mode of the Task Writer screen is structured as follows:

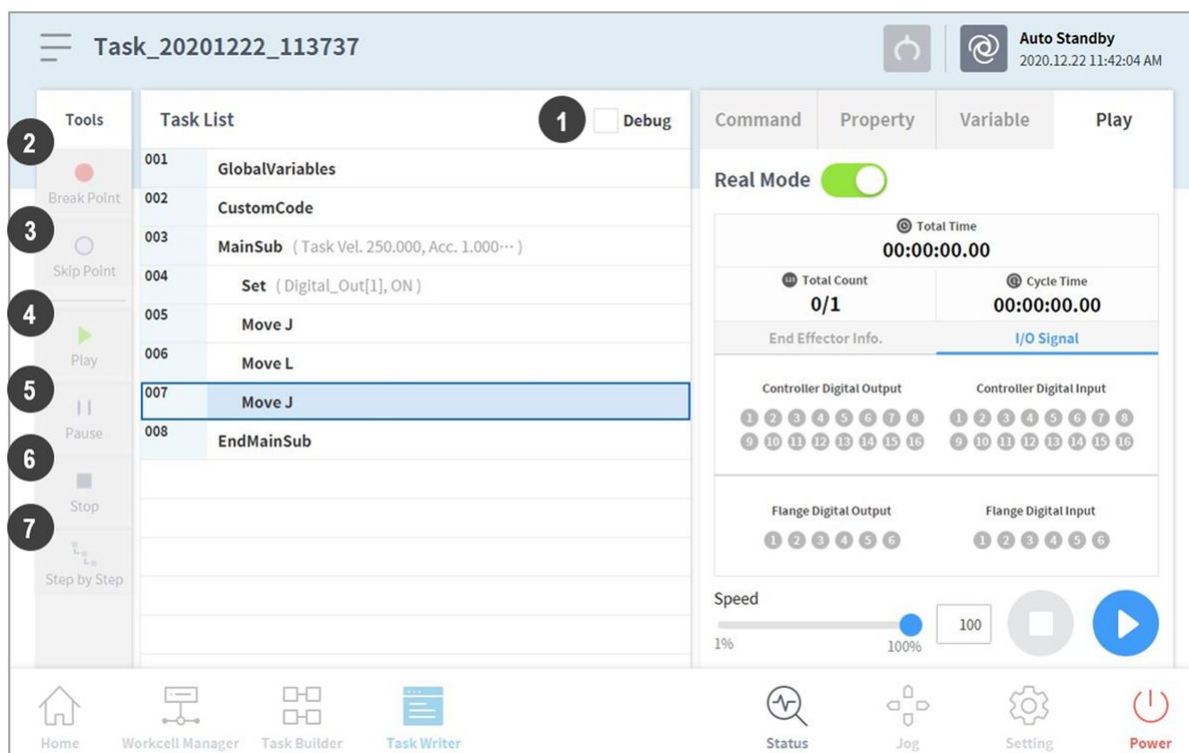

No.	Item	Description
1	Debug	Sets the robot test play debug mode.
2	Break Point Button	Sets a break point in a command. When the command is reached after executing the task, the robot does not execute the task and stops.
3	Skip Point Button	Sets a skip point in a command. When the command is reached after executing the task, the robot does not execute the task.
4	Play/Restart Toggle Button	Executes the task in debug mode. If the break point is reached during task execution or if the task is paused, the button changes to the Restart button.
5	Pause Button	Temporarily pauses the current task execution.
6	Stop button	Suspends the current task.
7	Stage by Stage	Executes one command at a time while the task is paused.

4.10.4 Task Execution and Stopping

Tap the **Execute** button on the **Home** screen to view, execute or stop tasks.

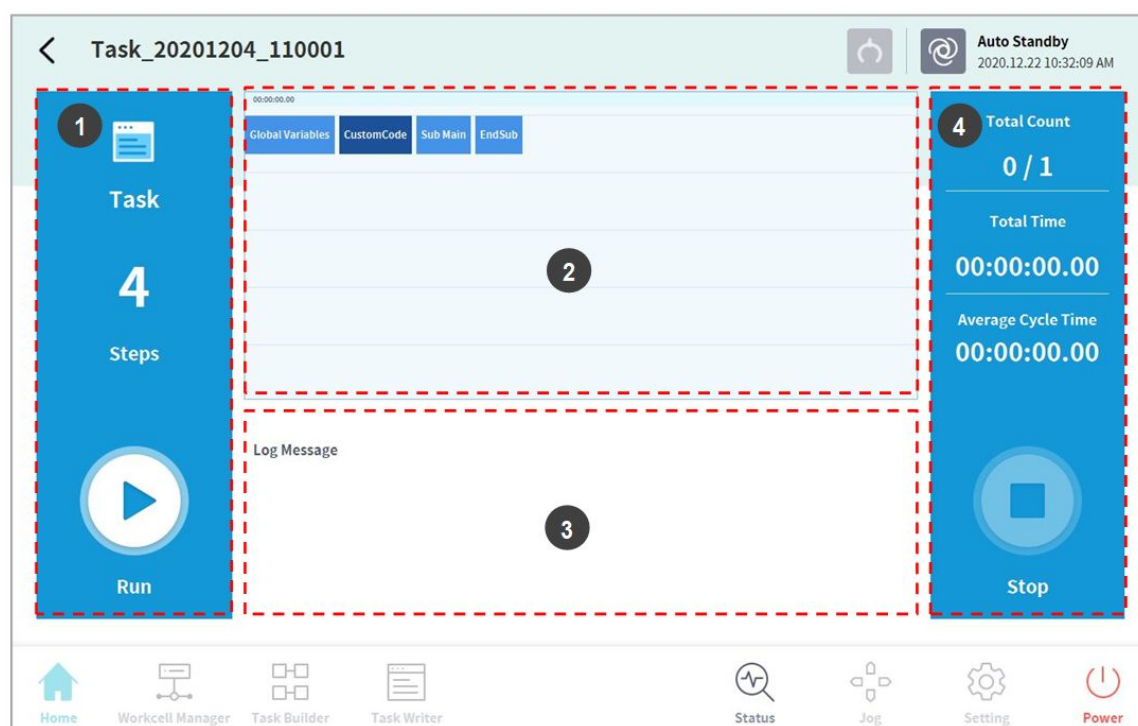

No.	Item	Description
1	Start/Pause Task	The total number of lines of the task program is displayed. Tap the  Execute button to execute or pause the task.
2	Task Information Check	The command the robot is executing repeatedly can be checked.
3	Log Message	Displays log information of the task.
4	Task Execution Information and Stop	Displays task repetition count, play time and average one cycle execution time. Tap the Stop button to stop the current task.

4.10.5 Load Saved Tasks

Tasks saved on the system can be loaded from the **Home** screen.

1. Tap the  Menu button on the top left of the Home screen.
2. Tap **Open**.
 - A list of tasks saved on the system is displayed on the screen right.
3. Tap the task to execute from the list.

- Moves to the screen to check and execute tasks.

Note

At first start-up of the system, the list is empty.

4.11 Environment Setting

To configure environment settings related to the operation setting, tap the **Settings** button in the main menu.

Note

When the **Task Builder** and **Task Writer** screens are changed to the **Play** tab, the **Settings** button on the main menu is disabled.

4.11.1 Language Setting

To set the UI language of the operation program, follow these steps:

1. Tap the **Setting** button on the main menu and select **Local > Language**.
2. Select the language from the language list and tap the **Confirm** button.
3. To change the SI units to U.S. units, select “English (INCH)” and tap the Confirm button.
 - The units displayed on the program change to U.S. units.
4. Restart the system.

4.11.2 Date and Time Setting

To set the date, follow these steps:

1. Tap the **Settings** button on the main menu and select **Date and Time > Date**.
2. Set the date and tap the **Confirm** button.

To set the time, follow these steps:

1. Tap the **Settings** button on the main menu and select **Date and Time > Time**.
2. Set the time and tap the **Confirm** button.

Note

- The log time of the logs saved in the system maintain the existing date and time even after changing the date and time of the system.
- If the system is accessed via Windows, the Date and Time setting function is not available, and the system automatically synchronizes with the date and time of Windows.

4.11.3 Robot Setting

Configures the default pose and cockpit related functions.

Remote Control Setting

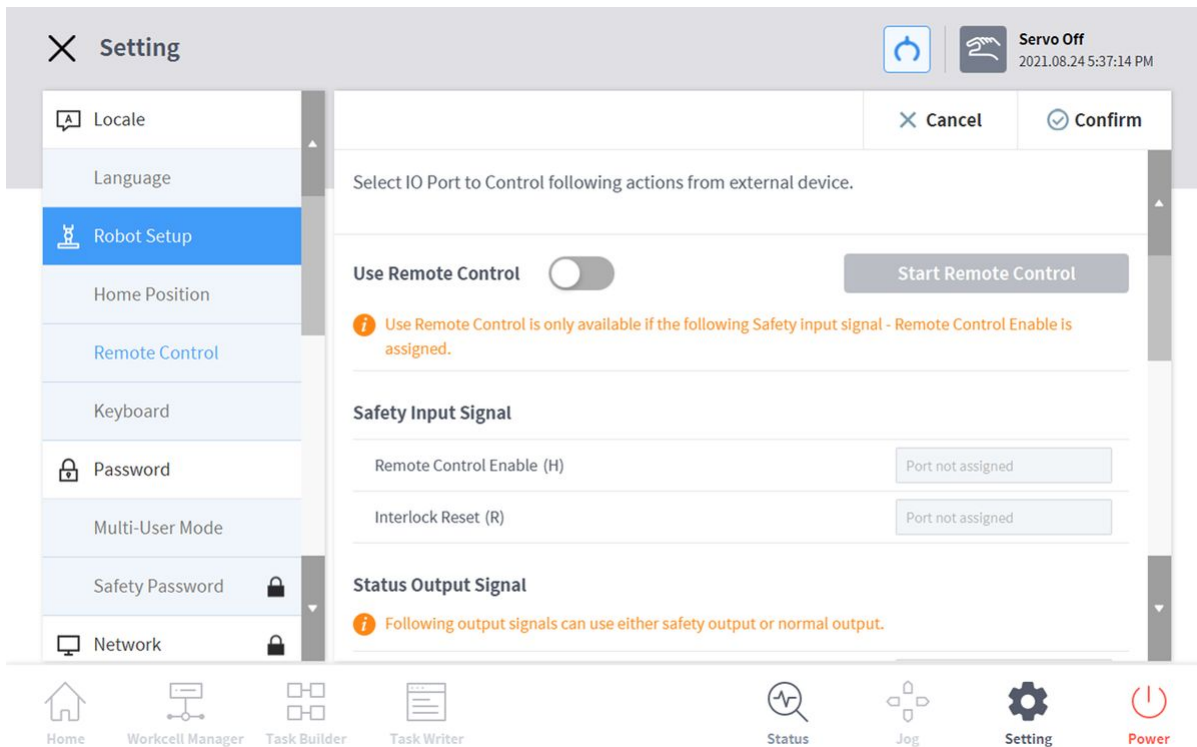

1. Select the **Remote Control** menu in the **Setting > Robot Setup** menu.
 - The current setting information is displayed in the setting management window.
2. Set **Safety Input signal**.
 - In the **Workcell Manager > Safety I/O > Input Tab**, select **Edit > Port** and set **Remote Control Enable(H)**.

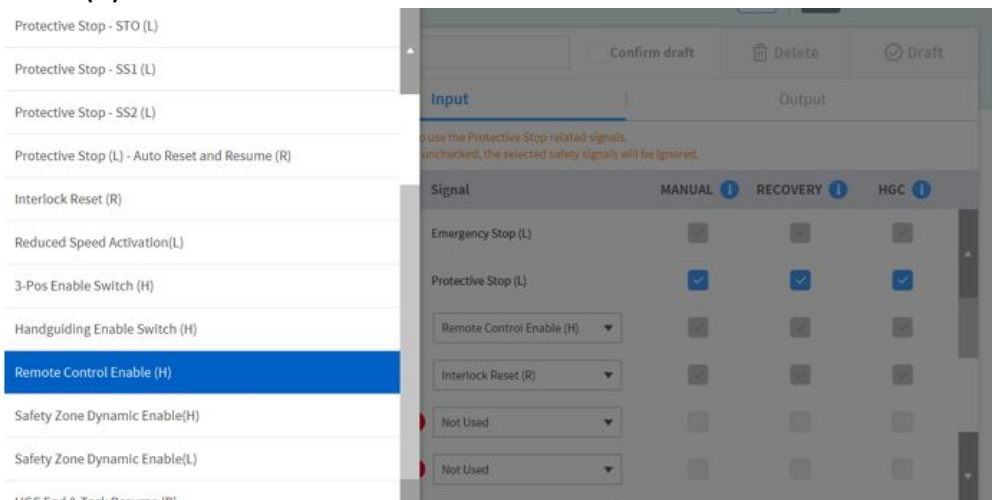

3. Set the **Use Remote Control** button to **ON**.
 - If the system is restarted with remote control set to **ON**, it boots up in **remote control mode**.

Use Remote Control 

4. Enter the **Status Output Signal** selection value

- Output signals can be set in **Workcell Manager > Safety I/O output tab** and **Normal I/O output tab**.
Status Output Signal

 Following output signals can use either safety output or normal output.

Safe Torque Off (L)	Port 12
Safe Operating Stop (L)	Port 14
Emergency Stop (L)	Port 1 - 2
Task Operating (L)	Port 16
Abnormal (L)	Port 3 - 4

- **Safety I/O** setting items
 - Emergency Stop (L)
 - Abnormal (L)
- **Normal I/O** setting items
 - Safe Torque Off (L)
 - Safe Operating Stop (L)
 - Task Operating (L)

5. Enter **Control Input Signal** selection value

- Remote control use button ON, cannot be set if the safety input signal is not set.

6. Enter **Default Load Task** selection values

- Remote control use button ON, cannot be set if the safety input signal is not set.

7. Tap the **Confirm** button when complete.

- This completes the environment settings for remote control.



8. To allow remote control using an external device, tap the **Start Remote Control** button to engage remote control mode.

- Information on tasks to execute from the external device appears.
- Motion inputs from the external device can only be executed if a green signal is displayed on the “Enable Remote Control” button.
- If a red signal is displayed on the Enable Remote Control button, input an enable signal from the external device.

 **Note**

- If the Emergency Stop or Protective Stop occurs in Remote Control Mode, it is handled as follows:
 - a. Emergency Stop: An emergency stop popup is displayed. After removing the cause of emergency stop - pulling or twist the emergency stop switch for reset, the popup closes automatically.

- b. Protective Stop causing the transition to **Servo Off** state: A red protective stop popup is displayed. If **Servo On** signal is entered after removing the cause of protective stop, the robot servo drives turn on and the popup closes automatically.
 - c. Protective Stop causing the transition to **Interrupted** state: A yellow protective stop popup is displayed. If **Interlock Reset** signal is entered after removing the cause of protective stop, the robot state changes to normal standby state – Manual Standby, Auto Standby, or HGC standby. For the safety violations where the cause of them cannot be removed without moving the robot, Clamping Escape by cockpit can be used.
 - d. For details on status for each mode, please refer to [Status and Flange LED Color for Each Mode](#)(p. 16).
- It is possible to turn ON/OFF the power of the robot by remote control setting
 - a. Tap the Settings button of the main menu and select **Remote Control** under **Robot Settings**.
 - b. Select the dedicated input port for remote control to use **Power On** or **Power Off** function.

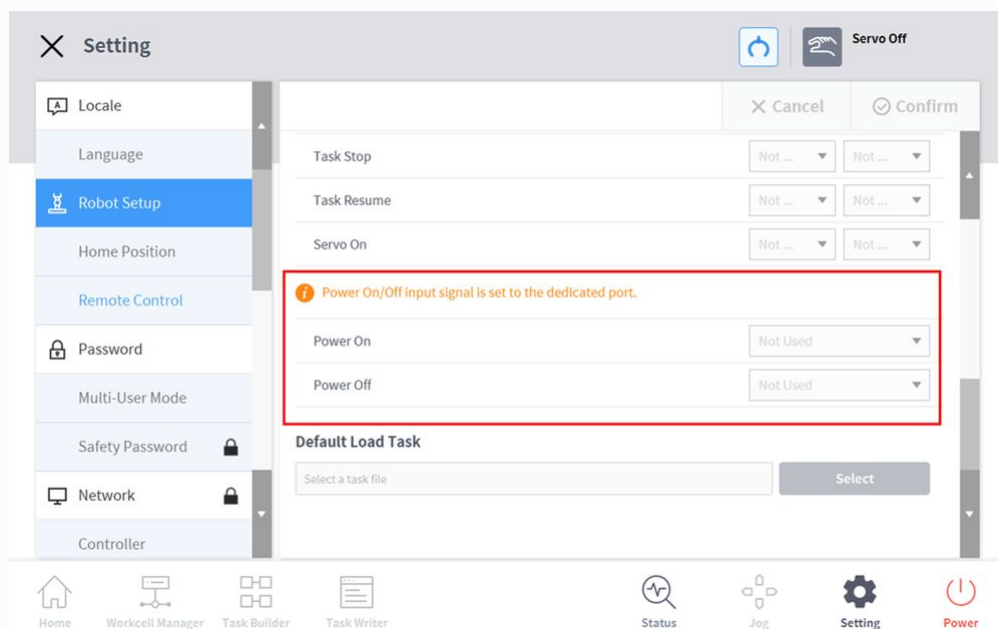

Cockpit Setting

1. Tap the **Settings** button on the main menu and select **Robot Settings > Cockpit**.
2. Select individual functions for **Button 1** and **Button 2** from the drop-down list.
3. To activate **Clamping Escape**, press and hold **Button 1** and **Button 2** simultaneously for 2 seconds.
4. When selection is completed, tap the **Confirm** button.



Note

The values of **Button 1** and **Button 2** must be different.

Robot Home Position Setting

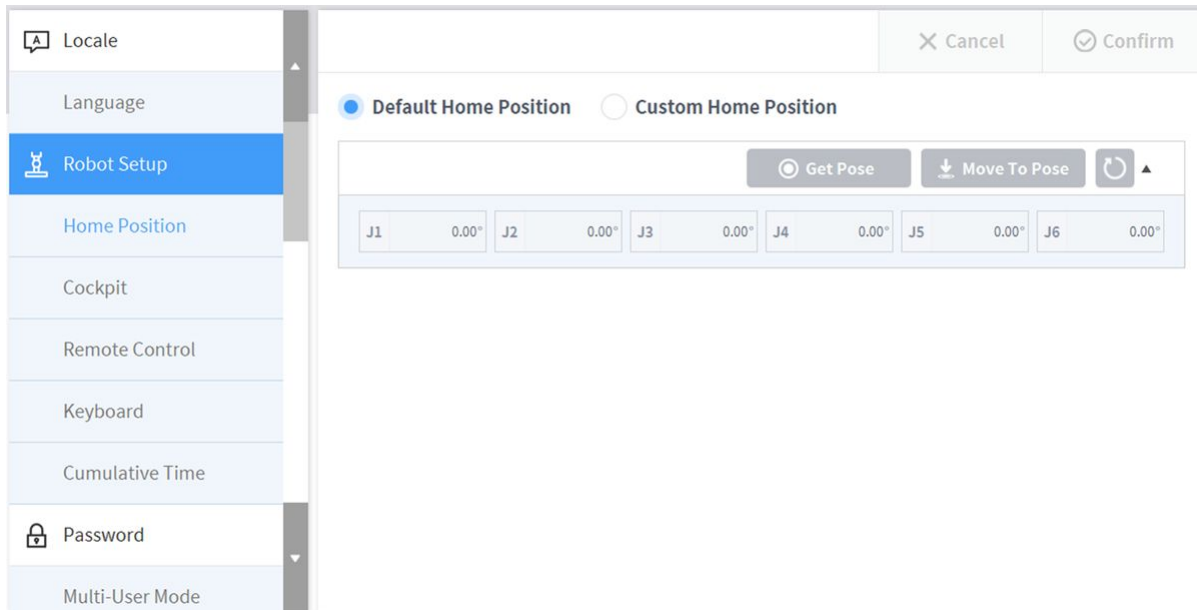

1. Tap the **Settings** button on the main menu and select **Robot Settings > Home Position**.
2. Select the **User Home Position**.
 - Selecting **Default Home Position** sets the default.
3. Move the robot to the desired position and tap the **Save Pose** button.
4. Tap the **Confirm** button.

Warning

- When a robot or joint of a robot is being swapped, User Home Position must be reset using the teach pendant.
- When performing a backup/restore, you must reset the user home position on the teach pendant.
- The User Home Position setting of DART Studio is not reflected on the teach pendant. If the User Home Position is set using DART Studio and then used with the teach pendant, the User Home Position must be reset.

Flange I/O Setting

The screenshot displays the 'Flange I/O Setting' window. At the top, there is a 'Setting' header with a close button (X) and a 'Servo Off' status indicator showing the time '2024.04.30 4:51:40 PM'. Below the header, there are 'Cancel' and 'Confirm' buttons. A message states: 'I/O settings can be made according to the flange connector.' with an information icon and a 'Reset' button.

The main settings area is titled 'Flange I/O Setting' and includes the following configurations:

- Supply Voltage:** X1 / X2: 0V(Off)
- Digital Output Type:** X1: PNP, X2: PNP
- Analog Input/RS485:** X1: Analog, X2: Analog
- Serial Settings:** Baud Rate: 115200, Data Bit: 8, Parity Bit: None, Stop Bit: 1

The bottom navigation bar contains icons for: Home, Workcell Manager, Task Builder, Task Writer, Status, Jog, Setting (highlighted), and Power.

I/O settings can be made according to the flange connector. 

Reset

Flange I/O Setting	
Supply Voltage	X1 / X2 0V(Off) ▼
Digital Output Type	X1 PNP ▼
	X2 PNP ▼
Analog Input/RS485	X1 Analog ▼
Baud Rate	115200 ▼
Data Bit	8 ▼
Parity Bit	None ▼
Stop Bit	1 ▼
	X2 Analog ▼
Baud Rate	115200 ▼
Data Bit	8 ▼
Parity Bit	None ▼
Stop Bit	1 ▼

Reset

End Effector Power Interlock	X1 / X2
Servo Off	Maintaining power voltage & digital output ▼
Interrupted	Maintaining power voltage & digital output ▼

- In the Settings menu area, select the **Flange I/O** menu in Robot Settings (only visible when a new flange is connected)
 - The currently set information appears in the Settings Management window.
- Change options in **flange I/O settings (X1/X2)**
 - Supply Voltage
 - 0V/12V/24V(default) power supply function
 - Digital output type
 - PNP / NPN
 - Analog Input/RS485
 - Use **X1/X2** ports as **analog input** or **RS485**
 - When selecting **RS485**, please set **Baud Rate**, **Data Bit**, **Parity Bit**, and **Stop Bit**.
- Change options for **End Effector Power Interlock**
 - Servo Off
 - Maintaining power voltage & digital output

- Switch the power voltage & digital output to 0V and revert to the last state when Servo On.
 - Interrupted
 - Maintaining power voltage & digital output
 - Switch the power voltage & digital output to 0V and revert to the last state when reset.
4. When finished, press the **OK** button.
- Your environment setup to use **flange I/O** is now complete.

Note
A series only displays X1.

Keyboard Setting

If a wired or wireless keyboard is used, soft keyboard option of each operating environment can be set.

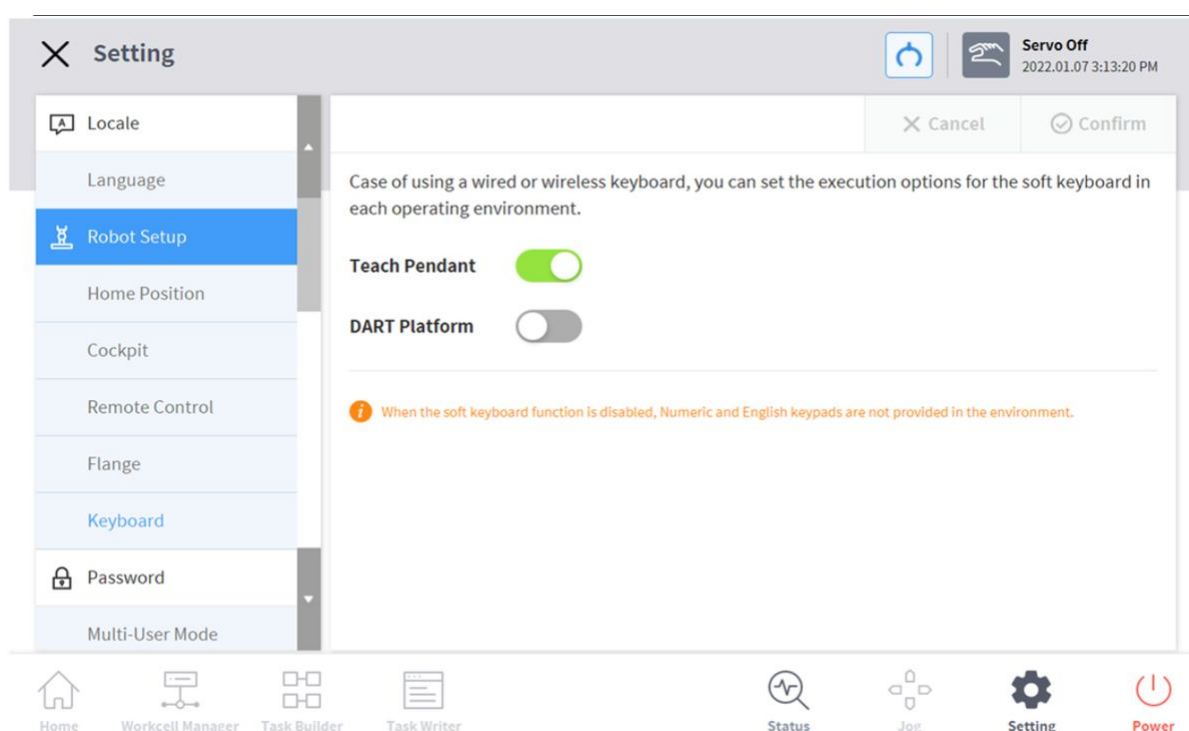

4.11.4 Change and Disable Password

A password is required to enter a setting with a lock icon (🔒).

To change or disable the password of settings with a lock icon, follow these steps:

1. Select **Password > Safety Password** in the Settings menu.
2. Enter the current password of the program and tap the **Confirm** button.
 - The initial system password is admin.
 - To disable the password, tap the **Password Lock** button and disable.

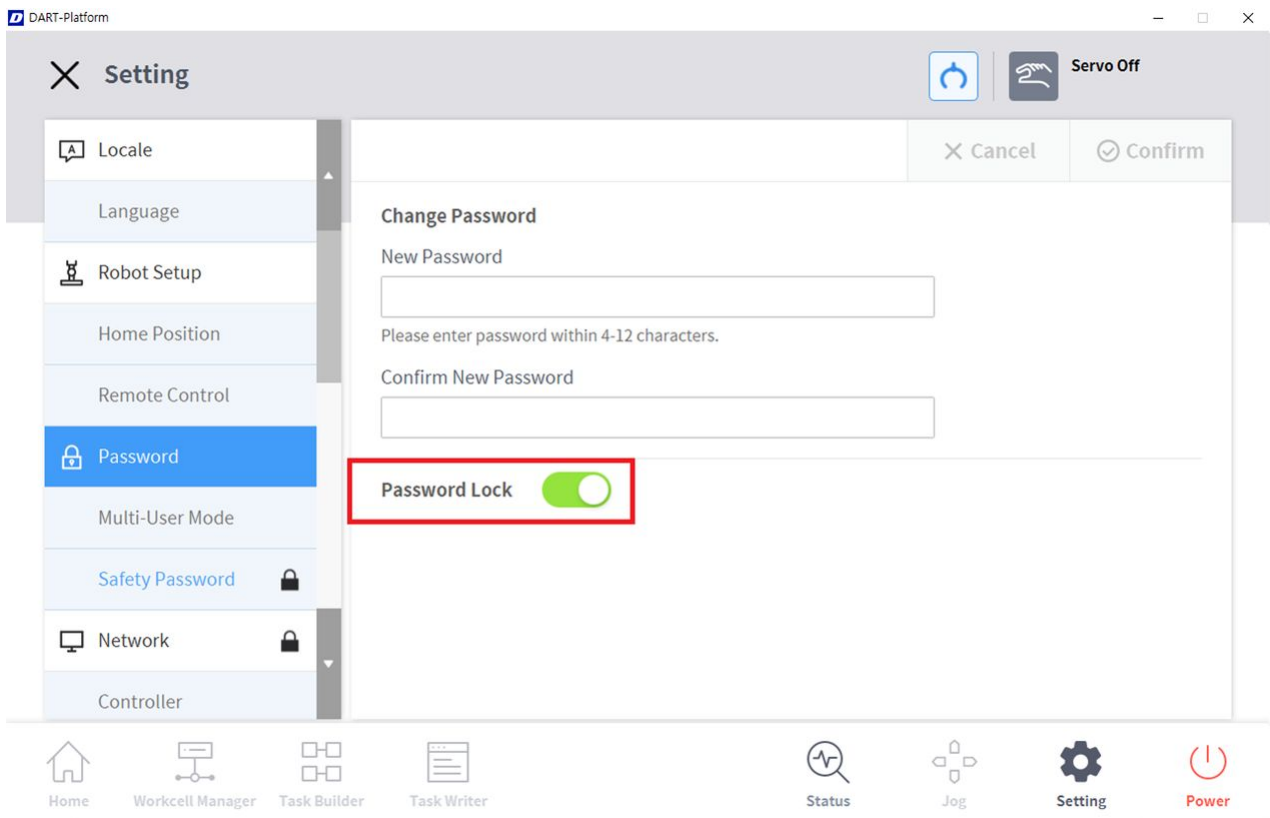

3. Tap the **Confirm** button.



Note

Even if the password lock is disabled, rebooting the system will enable password lock.

4.11.5 User Role Setting

Accessible menus can be limited according to user roles.

1. Select **Password > Use User Role** in the Settings menu.

- The User Role On/Off, description of user role and Change Password buttons appear in the settings management window.

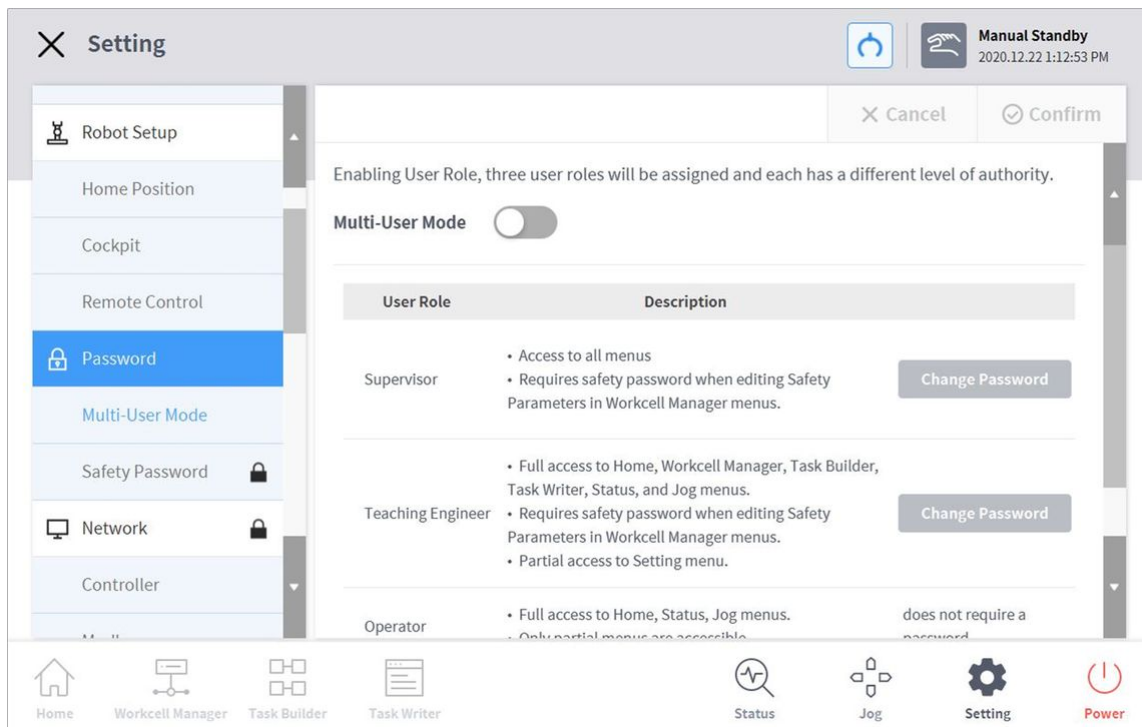

2. To enable/disable a user role, press the User Role On/Off button.
 - A screen asking for the administrator password is displayed.
 - When user authority is changed from Off to On, the screen returns to the Home screen and changes to operator role.
3. Enter the new password in the Change Password field and tap the **Confirm** button.
 - Password change settings are complete.
4. To change a user role, tap the **User Role button**.



Note

- The initial administrator password is **admin**.
- The initial teaching engineer password is **admin**.
- If the **User Role button** is disabled, it operates in the same way as an administrator role.

4.11.6 Network Setting

To set the network, follow these steps:

1. Tap the **Settings** button of the main menu and select **Network**.
2. Select the **Controller** or **Modbus** tab.
 - **Controller:** Ethernet network settings for external connections such as the controller or Modbus can be configured.
 - **Modbus:** Additional settings for user-defined Modbus including Modbus TCP/RTU and additional settings for Preset Modbus used by some Workcell items can be set.
3. Select the network method and tap the **Confirm** button.

주의

- When setting IP address of the controller, the address in 10.0.0.X range which is used by assigning internally, cannot be used.
- If you are using industrial communications, use static IP.

Note

1. There is no IP setting function for connecting to PLC in Robot TP UI.
 - a. Therefore, PLC should be connected to (default) 192.168.137.100 to communicate with robot.
2. You can change the robot IP in PLC control program. (PLC program tested_Studio5000, TIA Portal)
 - a. If you change the robot IP to 10.80.114.200 in PLC control program,
 - b. After that, even if you turn off and on the robot power, the robot IP (for communication with PLC) will remain as 10.80.114.200.
3. If you change the IP to Robot TP without changing the robot IP in PLC control program and connect PLC,
 - a. After that, if you turn off and on the robot power, the robot IP (for communication with PLC) will return to 192.168.137.100.

User-defined Modbus Support Function Code

The Modbus Master of Doosan Robotics can be used for I/O expansion or data exchanges through connections with other devices.

The Function Codes supported by Doosan Robotics are as follows:

Function Code	Description
1	Read Coils
2	Read Discrete Inputs
3	Read Multiple Holding Registers
4	Read Input Registers

5	Write Single Coil
6	Write Single Holding Register
15	Multiple Coils (FC15)
16	Multiple Holding Registers (FC16)

- DRL (set_modbus_outputs()) is configured to internally call FC5 and FC6 multiple times.

Note

- Up to five Modbus Slave devices can be connected.
- Each device can register up to 50 registers.
- The total number of registers cannot exceed 100.

Register User-defined Modbus

Modbus communication with random devices can be performed using a user-defined Modbus.

1. Select the **Modbus** menu from **Settings > Network** and select the **Add TCP Slave** or **Add RTU Slave** button.
2. The Modbus slave will be added to the Modbus Slave List.
3. To set the Modbus slave and to add/delete signals, select the **View** button.
4. In the case of a TCP Slave, enter the IP address of the slave device and set the Port (default: 502).
5. In the case of a RTU Slave, select the **Serial Port** to perform communication, and set **Communication Speed**, **Parity Bit**, **Data Bit** and **Stop Bit**. If the serial port has been added using a USB port, select the **Search** button to search the new device and select the Serial Port.
6. If a signal must be added, press the **Add Signal** button.
7. If a signal must be deleted, press the **Delete Signal** (-) button.
8. Set the **Signal Type**, **Signal Address**, **Signal Name** and **Slave ID** for the newly added signal.
 - In the case of a TCP Slave, the default Slave ID is 255. However, if Advanced Settings is checked, the Slave ID can be modified (1-247).
 - In the case of **Signal Type** Multiple Coils for FC 15 and Multiple Holding Registers for FC 16, select the **Edit** button to add multiple signals by entering the **Signal Name**, **Start Address** and **Count**. An individual signal name is assigned automatically by **Signal Name**.
9. Select the **Settings** button.
10. Modbus registration begins after selecting the **Settings** button, and a message is displayed if the process fails. In such case, check the connection with the Modbus device and the Modbus Slave settings.
11. If the Modbus has been successfully registered, the input and output of the registered signal can be checked.
 - An output motion can be performed by entering a value and selecting the → button.

Register Preset Modbus

Modbus communication with a specific Workcell item provided by Doosan Robotics can be performed using Preset Modbus. In such case, register a Preset Modbus and set the signal in Workcell Manager.

1. Select the **Modbus** menu from **Settings > Network** and select the **Add TCP Slave** or **Add RTU Slave** button.
2. A Modbus Slave is added to the Modbus Slave List and performs Modbus registration, and a message is displayed if the process fails.
3. To check the status of the signal registered to the Modbus Slave, select the **View**. If the registration process fails, check the connection with the device and select the **Settings** button.
4. If the Modbus has been successfully registered, the input and output of the registered signal can be checked from the Details screen.
 - An output motion can be performed by entering a value and selecting the **→** button.

Note

- The Modbus RTU function is provided through DRL.
- DRL used for ModbusRTU Master only added `add_modbus_rtu_signal()`.
- Other DRLs are used in the same way, except for `add_modbus_signal()`, which is used to add signals.
- DRL (`serial_get_count()`, `serial_get_info()`) are added to check serial port information.
- For more detailed description about DRL, refer to the Programming Manual.

4.11.7 System Update

The current robot system version can be checked, and the system can be updated using an external storage device.

Unified Update

This provides new unified updates. The unified update file updates the entire system including the user software, robot inverter and safe mode.

1. Connect the external storage device with the update file to the controller.
2. Tap the **Settings** of the main menu, and select **Robot Update > Update**.
3. Tap the **Update** button on the teach pendant and controller.
4. When the update window appears, tap the **Search** button.
5. Select the update file from the searched list.
6. Tap the **Check File** button.
 - If the file check is successful, **Version to Install** below will display version information, and the **Next** button will be enabled.
 - If the file check fails, examine the file for any issues.
7. Tap the **Next** button.
8. Read the Cautions and Terms and Conditions for Agreement, and tap the checkbox below to enable the **Agree and Proceed** button.

9. Tap the **Agree and Proceed** button.
10. Tap the **Start Update** button.
 - Once the update starts, the progress and update log can be viewed from this screen.
11. When the update is complete, restart the system. The controller must be restarted to ensure proper operation.
12. If the update fails, tap the **Restart Update** button to reinstall or the **Restore Previous Version** button to restore the version before the update.
13. Restarting the system without a successful update will activate App Recovery Mode. Reinstall the update using Unified Update in App Recovery Mode to complete the update. The update must be successfully installed to ensure proper operation.

 **Caution**

- Do not remove the external storage device or turn off the system during the update. This may damage the robot or cause malfunctions.
- If both Update Restart and Restore Previous Version fail, reboot and enter Recovery Mode to restore the system. For more information, refer to [Application Recovery Mode Screen](#)(p. 409).

 **Note**

- If the system is accessed via Windows, only controller software update is performed. Updates for the program from Windows must be performed separately.
- In addition, if the update is performed on Windows, the update cannot be performed in Servo On mode due to safety reasons. Perform the update with in Servo Off mode.

System Restore

Restores the robot system to a specific version the user chooses.

1. Select **Robot Update > System Restore** in the Setting menu.
 - The last five versions installed on the robot system are displayed.
 - The current version is displayed with the Radio button selected.
2. Select the Radio button of the version to be restored.
 - The Restore button is enabled.
3. Press the Restore button.
4. Restart the system when restore is complete.

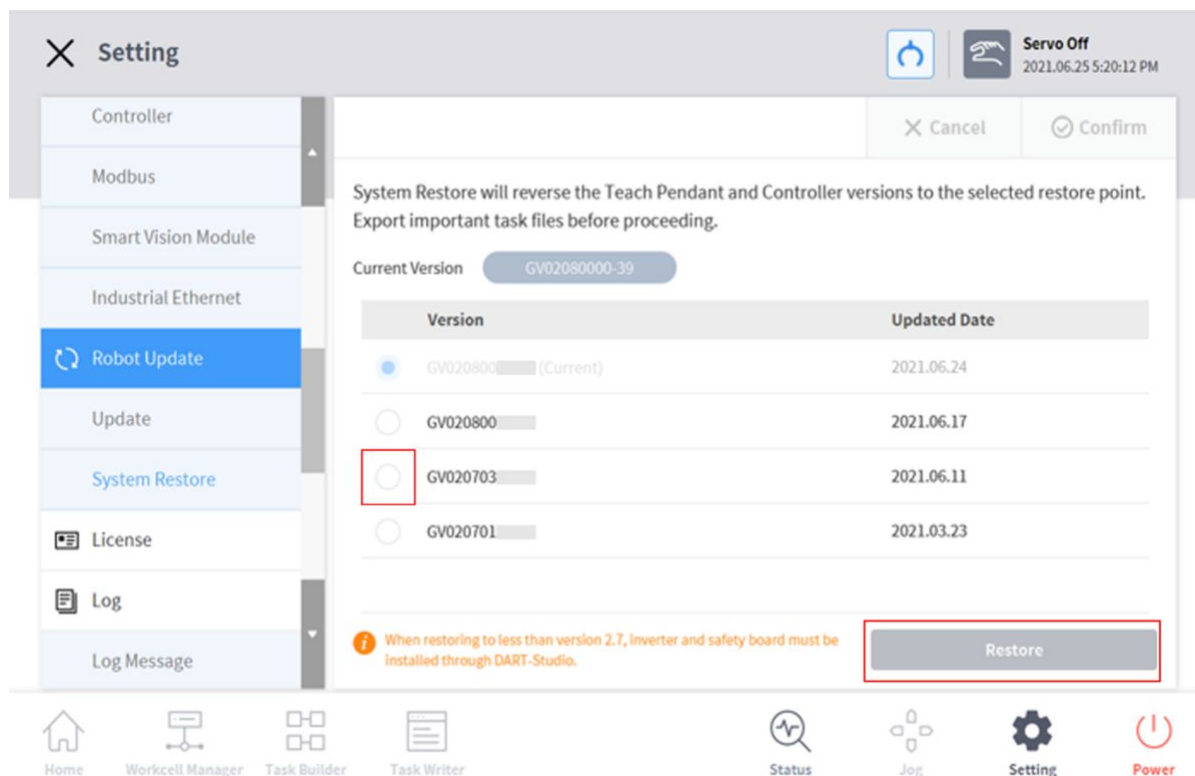

Note

If the system is accessed via Windows, the system restore function is not available.

Version : A Series

If one of the following issues occurs on an A Series product after System Restore, please refer to [\(2.12.3-en_US\) Friction Calibration⁸](#) to perform friction calibration.

1. If an issue makes direct teaching control difficult
 - If direct teaching does not operate properly even the tool weight and weight center point settings are correct
 - If the robot moves too fast or applies too much force when direct teaching is attempted
 - If control in a specific direction is difficult when direct teaching is attempted
 - If collision detection occurs frequently while the collision sensitivity is set to the default setting
2. If error “2.9015” occurs sporadically in the teach pendant
 - Error 2.9015: The external force of the robot tip has exceeded the safe range.

4.11.8 Check and Enter Robot License Code

The serial number and model number of the robot system can be checked, and the product license can be entered or checked. The serial number, model number and license are used for customer support services.

8. https://doosanrobotics-manual.atlassian.net/wiki/spaces/TESMT/pages/515410058/2.12.3-en_US+Friction+Calibration

To enter a new license code, follow these steps:

1. Tap the **Settings** button on the main menu and select **License**.
2. If the license requires an update, enter the newly issued license code and restart the system.

4.11.9 Check Log

Checking Log Messages

To check the log message of the robot, tap the **Settings** button and select **Log**.

Checking Real-time Log Messages During Program Execution

The Run screen under Home supports real-time logging. You can see logs of the Alarm, Warning, Message, and Comment types in real time as they occur during program execution. Each type can be toggled on/off and a maximum of 100 can be checked at once.

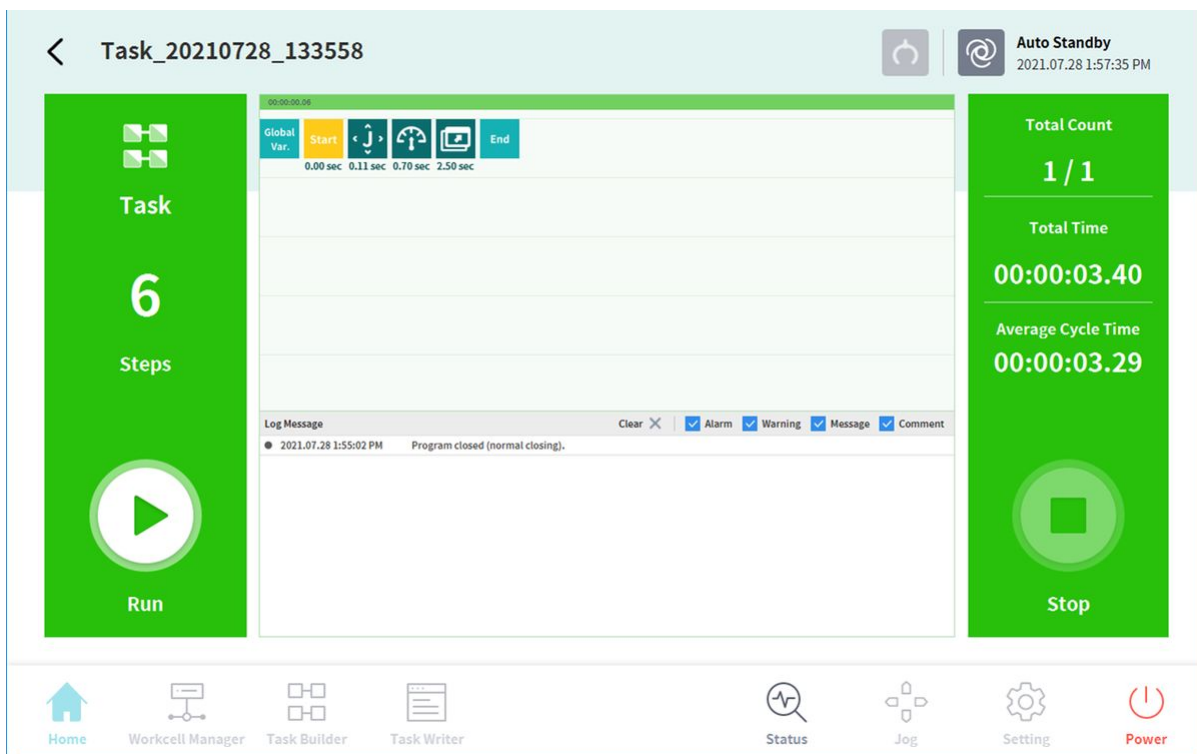

Extract Log

Logs created during robot operation can be saved on a USB storage media. Search can be made in units of 1 week.

4.11.10 Factory Reset

Factory reset is a function used to delete all user data and logs saved on the robot. When factory reset is performed, the database, log files, Workcell Items and task files are deleted.

1. Tap the **Setting** button on the main and select **Factory Reset**.
2. Tap the **Reset** button.
3. When reset is complete, restart the system.

Delete Log

Delete log is a function that deletes all logs saved on the robot.

How to delete Logs

- Tap the **Setting** button on the main menu and select **Factory Reset**.
- Tap the **Delete** button.
- Deletion status can be checked in **System Log Items**.

License Type and Factory Reset Range according to Vision Connection

Vision License Status	Vision Connection Status	Details	Remarks
O	O	Factory reset including Vision data	Vision Category of WCM screen retained
O	X	A Vision Connection-related popup* is displayed, and no factory reset	
X	O	Factory reset excluding Vision data	
X	X	Factory reset excluding Vision data	



Popup Message

Please connect the vision camera and proceed with factory reset.

4.11.11 Screen Saver Mode Setting

If the teach pendant is not used for a set amount of time, the system enters screen saver mode.

- The robot can enter screen saver mode even if it is operating in Auto mode.
- Tap the **Return** button on the screen saver to return to the previous screen.

To configure the screen saver mode, follow these steps:

1. Tap the **Settings** button on the main menu and select **Screen Saver**.
2. Screen saver use can be configured in the Screen Saver Setting screen.
 - The default setting is **Use Screen Saver**.



3. This configures the time required to elapse before entering the screen saver mode.
 - Default: 5 minutes
 - Minimum Time: 1 minute
 - Maximum Time: 24 hours (1440 minutes)
4. Tap the **Confirm** button.

4.11.12 Idle Servo Off

If the robot is idle for a certain amount of time, the robot is automatically set to the Safety Off state. The default value is 5 minutes, and the time can be changed to a time the user prefers

4.11.13 Backup & Restore

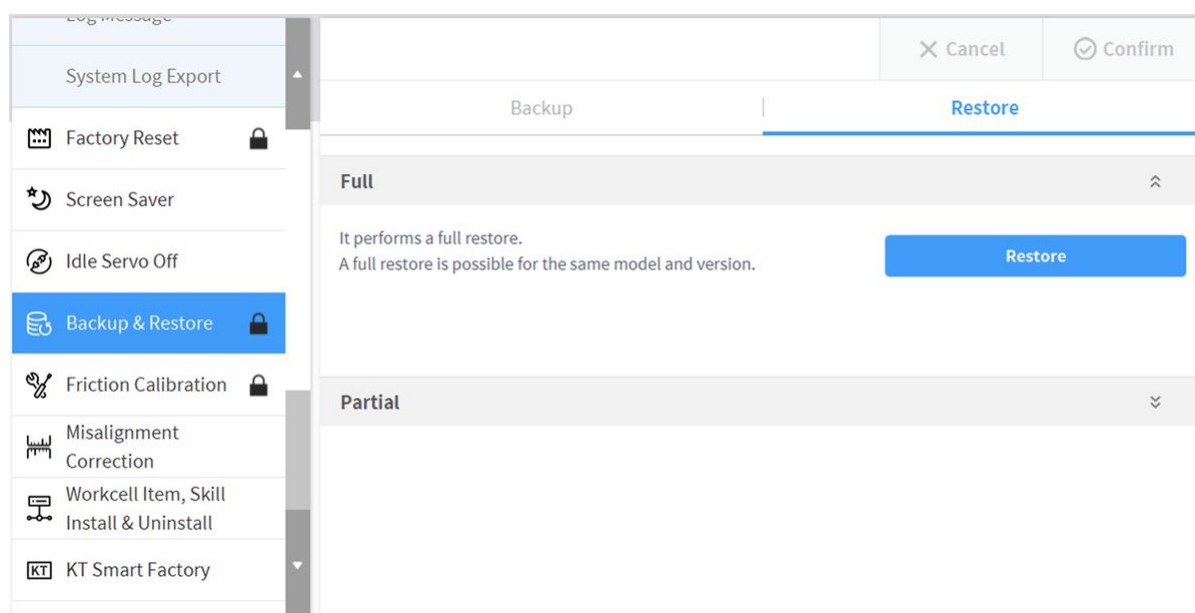

Some of the data used by the teach pendant can be backed up and restored.

The name of the backup file must consist of at most 20 alphanumeric characters. The only special character allowed is the underscore, and the name cannot have blank space at the front or back.

The file extension for overwrite backups is .replace, and the file extension for full backups is .full

For overwrite backup, Restore is only available for the same software version and the same robot series.

For full backup, Restore is only available for the same software version and the same robot model.

When a backup file including a Workcell item is restored, all Workcell items that can be disabled are disabled.

If the item to be restored is restored to a robot without the corresponding license, restoration is performed

normally, but any items with licenses are not displayed.

If an item from one of the categories below is included in the overwrite restore, the items in each of the existing categories are deleted and the back up data is restored.

Category	Range
Workspace	All working spaces (space limits, collaborative zones, collision avoidance zones, collision sensitivity reduction zones, tool orientation limit zones, user defined zones)
Tool Weight	All tool weights
Tool Shape	All tool shapes
Robot Installation Pose	All robot installation poses
User Coordinates	All user coordinates
End Effector	All end effectors
Machine	All machines
Peripherals	All peripherals (Smart Vision Module and welding condition are excluded)
System Parameters	All system parameters
Task Builder	All Task Builder tasks
Task Writer	All Task Writer tasks
Modbus	All Modbus Slaves

Workcell items from other companies downloaded through Doosan Mate can only be restored to robot models that the corresponding item was created.

Items that support all and individual data overwriting are as follows:

- Items registered in Workcell Manager
- System Parameters
- Task Builder Task file
- Task Writer Task file
- Settings (cockpit, remote control, smart pendant (A Series), Modbus, screen saver, idle servo off)

The following item is not available in both full backup and restore functions.

- Tool information set at the time of backup

To backup data, follow these steps:

1. Tap the **Settings** button and select Backup & Restore.
2. Choose whether to backup data for the purpose of add-on or overwriting.
3. (For backing up all data) Select the Backup All Data checkbox and press the Backup button.
4. (For backing up individual data) Select checkboxes for data items for backup and press the Backup button.
5. Select the directory to save.

To restore data, follow these steps:

1. Tap the **Settings** button and select Backup & Restore.
2. Press the Restore menu.
3. Choose whether to restore data with add-on or with overwriting.
4. Press the Restore button.
5. Select the file to be restored from the Select File pop-ups.
6. When restore is complete, restart the system.

 **Caution**

When performing a backup/restore, you must reset the user home position on the teach pendant.

4.11.14 Motion Power Limit

 Motion Power Limit feature is supported only on H2017, P3020.

The robot automatically slows down its motion speed to ensure that it does not exceed the set maximum watt.

When you select the appropriate voltage (V) for your environment, the watt (W) will be automatically entered.

If the automatically entered watt (W) differs from your actual environment, you can manually adjust it within the range.

Voltage Option

Please set it to 220V, as it is performed the same output processing even in voltage environments higher than 220V.

- Japan (100V)
- USA (120V)
- Korea/EU (220V)
- Custom (100V~220V)
- DC → For DC controllers, please enter the rated power of the power supply.

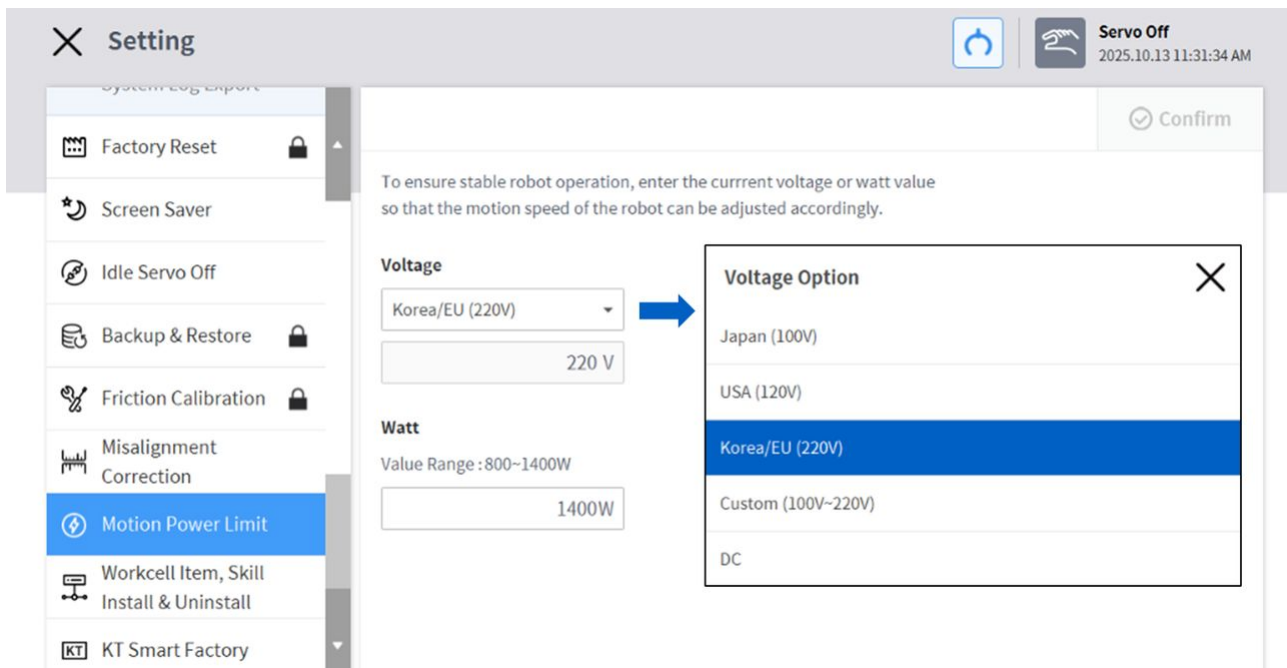

4.11.15 Workcell & Skill Installation and Removal

The list of external skills and workcells installed on the Teach Pendant can be viewed.

Information provided in the list includes name, manufacturer, version and status.

Installed skills and workcells can be deleted.

When deleting an installed skill or workcell, detailed information of the item to be deleted is displayed.

New items can be installed and executed.

Multiple items can be selected to be installed.

Rebooting after installation is required to ensure proper execution.

If a skill or workcell used by a task are deleted, the corresponding task cannot be opened.

4.11.16 KT Smart Factory Setting Screen

This screen sets the KT Smart Factory function.

1. Tap the **Settings** button and select **KT Smart Factory**.
2. Enter values according to the validation of each item.
3. Items required are IP address, port value, Device ID, Device Password, Gateway ID and transmission frequency.
4. Pressing the **Confirm** button applies the entered values.

5 Appendix

5.1 Appendix. System Specification

5.1.1 Manipulator

M0609

Classification	Item	Specification
Performance	Axis Structure	6
	Payload	6 kg
	Max. Radius	900 mm
	TCP Speed	1 m/s
	Repeatability	± 0.03 mm
Joint Movement	J1 Range / Speed	±360° / 150°/s
	J2 Range / Speed	±360° / 150°/s
	J3 Range / Speed	±150° / 180°/s
	J4 Range / Speed	±360° / 225°/s
	J5 Range / Speed	±360° / 225°/s
	J6 Range / Speed	±360° / 225°/s
Operating Environment	Operating Temperature	0 - 45 °C (273K-318K)
	Storage Temperature	-5 - 50 °C (268K-323K)
	Humidity	20-80%
Tool Flange & Connector	Digital I/O - X1	IN-3ch / Out-3ch

Classification	Item	Specification
	Digital I/O – X2	IN-3ch / Out-3ch
	Power Supply	DC 24V/ Max. 3A
	Connector	1424229, female (PHOENIX)
Weight		27 kg
Mounting		Any orientation
IP Rating		IP 54
Noise		< 65 dB

M1509

Classification	Item	Specification
Performance	Axis Structure	6
	Payload	15 kg
	Max. Radius	900 mm
	TCP Speed	1 m/s
	Repeatability	± 0.03 mm
Joint Movement	J1 Range / Speed	±360° / 150°/s
	J2 Range / Speed	±360° / 150°/s
	J3 Range / Speed	±150° / 180°/s
	J4 Range / Speed	±360° / 225°/s
	J5 Range / Speed	±360° / 225°/s
	J6 Range / Speed	±360° / 225°/s

Classification	Item	Specification
Operating Environment	Operating Temperature	0 - 45 °C (273K-318K)
	Storage Temperature	-5 - 50 °C (268K-323K)
	Humidity	20-80%
Tool Flange & Connector	Digital I/O - X1	IN-3ch / Out-3ch
	Digital I/O - X2	IN-3ch / Out-3ch
	Power Supply	DC 24V/ Max. 3A
	Connector	1424229, female (PHOENIX)
Weight		32 kg
Mounting		Any orientation
IP Rating		IP 54
Noise		< 65 dB

M1013

Classification	Item	Specification
Performance	Axis Structure	6
	Payload	10 kg
	Max. Radius	1300 mm
	TCP Speed	1 m/s
	Repeatability	± 0.05 mm
Joint Movement	J1 Range / Speed	±360° / 120°/s
	J2 Range / Speed	±360° / 120°/s

Classification	Item	Specification
	J3 Range / Speed	$\pm 160^\circ / 180^\circ/s$
	J4 Range / Speed	$\pm 360^\circ / 225^\circ/s$
	J5 Range / Speed	$\pm 360^\circ / 225^\circ/s$
	J6 Range / Speed	$\pm 360^\circ / 225^\circ/s$
Operating Environment	Operating Temperature	0 - 45 °C (273K-318K)
	Storage Temperature	-5 - 50 °C (268K-323K)
	Humidity	20-80%
Tool Flange & Connector	Digital I/O - X1	IN-3ch / Out-3ch
	Digital I/O - X2	IN-3ch / Out-3ch
	Power Supply	DC 24V/ Max. 3A
	Connector	1424229, female (PHOENIX)
Weight		33 kg
Mounting		Any Orientation
IP Rating		IP 54
Noise		< 65 dB

M0617

Classification	Item	Specification
Performance	Axis Structure	6
	Payload	6 kg
	Max. Radius	1700 mm

Classification	Item	Specification
	TCP Speed	1 m/s
	Repeatability	± 0.1 mm
Joint Movement	J1 Range / Speed	±360° / 100°/s
	J2 Range / Speed	±360° / 100°/s
	J3 Range / Speed	±165° / 150°/s
	J4 Range / Speed	±360° / 225°/s
	J5 Range / Speed	±360° / 225°/s
	J6 Range / Speed	±360° / 225°/s
Operating Environment	Operating Temperature	0 - 45 °C (273K-318K)
	Storage Temperature	-5 - 50 °C (268K-323K)
	Humidity	20-80%
Tool Flange & Connector	Digital I/O - X1	IN-3ch / Out-3ch
	Digital I/O - X2	IN-3ch / Out-3ch
	Power Supply	DC 24V/ Max. 3A
	Connector	1424229, female (PHOENIX)
Weight		34 kg
Mounting		Any Orientation
IP Rating		IP 54
Noise		< 65 dB

H2017

Classification	Item	Specification
Performance	Axis Structure	6
	Payload	20 kg
	Max. Radius	1700 mm
	TCP Speed	1m/s
	Repeatability	± 0.1mm
Joint Movement	J1 Range / Speed	±360° / 100°/s
	J2 Range / Speed	±125° / 80°/s
	J3 Range / Speed	±160° / 100°/s
	J4 Range / Speed	±360° / 180°/s
	J5 Range / Speed	±360° / 180°/s
	J6 Range / Speed	±360° / 180°/s
Operating Environment	Operating Temperature	0 °C to 45 °C (273 K to 318 K)
	Storage Temperature	-5 °C to 50 °C (268 K to 323 K)
	Humidity	20 % to 80 %
Tool Flange & Connector	Digital I/O - X1	IN-3ch / Out-3ch
	Digital I/O - X2	IN-3ch / Out-3ch
	Power Supply	DC 24V/ Max. 3A
	Connector	1424229, female (PHOENIX)
Weight		79 kg

Classification	Item	Specification
Mounting		Only Floor
IP Rating		IP 54
Noise		< 65 dB

H2515

Classification	Item	Specification
Performance	Axis Structure	6
	Payload	25 kg
	Max. Radius	1500 mm
	TCP Speed	1m/s
	Repeatability	± 0.1mm
Joint Movement	J1 Range / Speed	±360° / 100°/s
	J2 Range / Speed	±125° / 80°/s
	J3 Range / Speed	±160° / 100°/s
	J4 Range / Speed	±360° / 180°/s
	J5 Range / Speed	±360° / 180°/s
	J6 Range / Speed	±360° / 180°/s
Operating Environment	Operating Temperature	0 °C to 45 °C (273 K to 318 K)
	Storage Temperature	-5 °C to 50 °C (268 K to 323 K)
	Humidity	20 % to 80 %
Tool Flange & Connector	Digital I/O - X1	IN-3ch / Out-3ch

Classification	Item	Specification
	Digital I/O – X2	IN-3ch / Out-3ch
	Power Supply	DC 24V/ Max. 3A
	Connector	1424229, female (PHOENIX)
Weight		77 kg
Mounting		Only Floor
IP Rating		IP 54
Noise		< 65 dB

5.1.2 Controller

CS-01 (AC Controller)

Item	Specification
Weight	13 kg
Dimensions	525 x 287 x 390 mm
Material	Zinc Plated Steel
Protection Rating	IP30
Interfaces	RS232/RS422/RS485, TCP/IP (*RS232/RS422/RS485: USB to Serial converter not included)
Industrial Network	ModbusTCP (Master/Slave), ModbusRTU (Master), PROFINET IO (Device), EtherNet/IP (Adapter) (* In case of using a gateway, Other communication type can be supported)
NC Interface	FANUC - FOCAS
I/O Port – Digital I/O	16/16

Item	Specification
I/O Port – Analog I/O	2/2
I/O power supply	DC 24V
Rated supply voltage	100-240VAC 47-63 Hz
Cable Length	6 m (Option: 3 m)

CS-02 (DC Controller)

Item	Specification
Weight	12 kg
Dimensions	462 x 218 x 295 mm
Material	Zinc Plated Steel
Protection Rating	IP20
Interfaces	RS232/RS422/RS485, TCP/IP (*RS232/RS422/RS485: USB to Serial converter not included)
Industrial Network	ModbusTCP (Master/Slave), ModbusRTU (Master), PROFINET IO (Device), EtherNet/IP (Adapter) (* In case of using a gateway, Other communication type can be supported)
NC Interface	FANUC - FOCAS
I/O Port – Digital I/O	16/16
I/O Port – Analog I/O	2/2
I/O power supply	DC 24V
Rated supply voltage	22-60 VDC
Cable Length	3 m (Option: 6 m)

CS-01P (Protected AC Controller)

Item	Specification
Weight	17 kg
Dimensions	577 x 241 x 422 mm
Material	Zinc Plated Steel
Protection Rating	IP54
Interfaces	RS232/RS422/RS485, TCP/IP (*RS232/RS422/RS485: USB to Serial converter not included)
Industrial Network	ModbusTCP (Master/Slave), ModbusRTU (Master), PROFINET IO (Device), EtherNet/IP (Adapter) (* In case of using a gateway, Other communication type can be supported)
NC Interface	FANUC - FOCAS
I/O Port – Digital I/O	16/16
I/O Port – Analog I/O	2/2
I/O power supply	DC 24V
Rated supply voltage	100-240VAC 47-63 Hz
Cable Length	6 m (Option: 3 m)

5.1.3 Teach pendant

TP-01

Item	Specification
Weight	0.8 kg
Dimensions	264 x 218 x 69 mm

Item	Specification
Protection Rating	IP40
Screen Size	10.1 inch
Cable Length	CS-01/CS-01P : 4.5 m (Option : 2.5 m) CS-02 : 2.5 m (Option : 4.5 m)

5.2 Appendix. Protected AC Controller (CS-01P)

5.2.1 Product Introduction (CS-01P)

Names and Functions

Protected AC Controller (CS-01P)

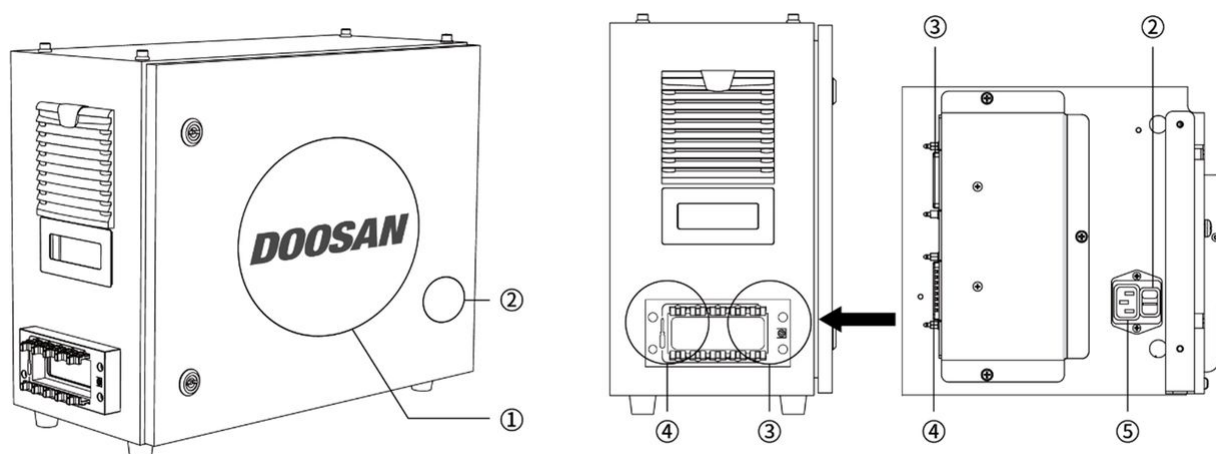

No.	Item	Description
1	I/O connection terminal (internal)	Used to connect the controller or peripherals.
2	Power switch	Used to turn ON/OFF the main power of the controller.
3	Teach pendant cable connection terminal	Used to connect the teach pendant cable to the controller.

4	robot cable connection terminal	Used to connect the robot cable to the controller.
5	Power connection terminal	Used to connect the controller power supply.

System Configuration

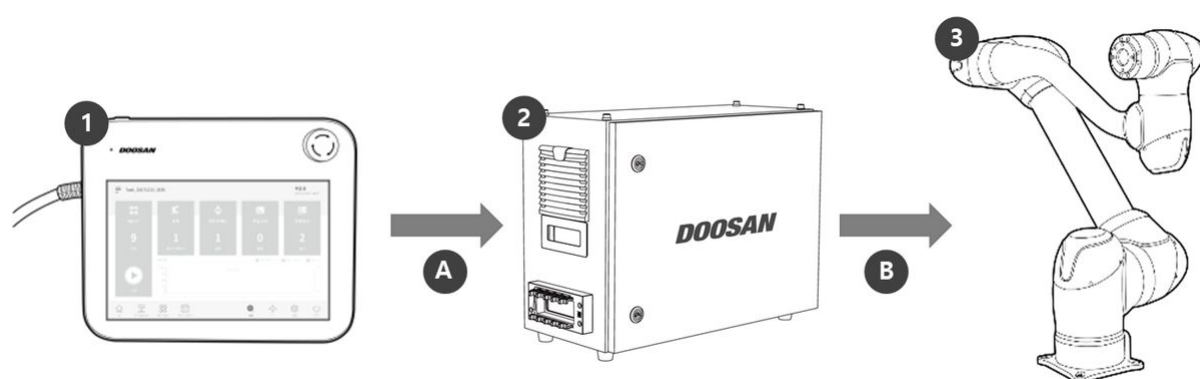

No.	Name	Description
1	Teach pendant	It is a device that manages the overall system, and it is capable of teaching the robot specific poses and setting manipulator and controller related settings.
2	Controller	It controls the robot's movement according to the pose or movement set by the teach pendant. It features various I/O ports that allow the connection and use of various equipment and devices.
3	Manipulator	It is an industrial collaborative robot that can perform transport or assembly tasks with various tools.
A	Command/Monitoring	
B	Power Supply/Network	

Nameplate and Label

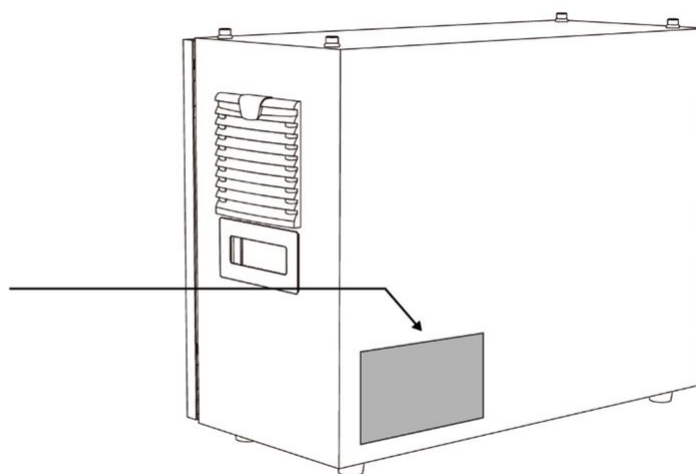
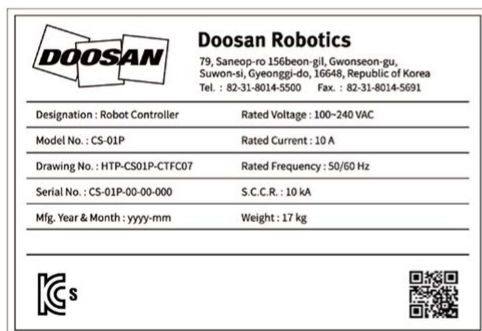

5.2.2 Installation (CS-01P)

Cautions during Installation

⚠ Caution

- Secure sufficient space for installation before installing the controller. If not enough space is secured, the controller may be damaged or the robot or teach pendant cable may have a shortage.
- Check the input power supply when connecting power to the product. If the connected input power supply is different from the rated power input (100-240VAC 50/60Hz), the product may not operate properly or the controller may be damaged.

Installation Environment

When installing the controller, consider the following.

- Secure sufficient space for installation before installing the controller.
- The controller must be fixed.

Hardware Installation

Install the robot, controller and teach pendant, the key components of the system, and supply power to them before operating the robot. Installation of each component is as follows:

Connecting the Manipulator and Controller

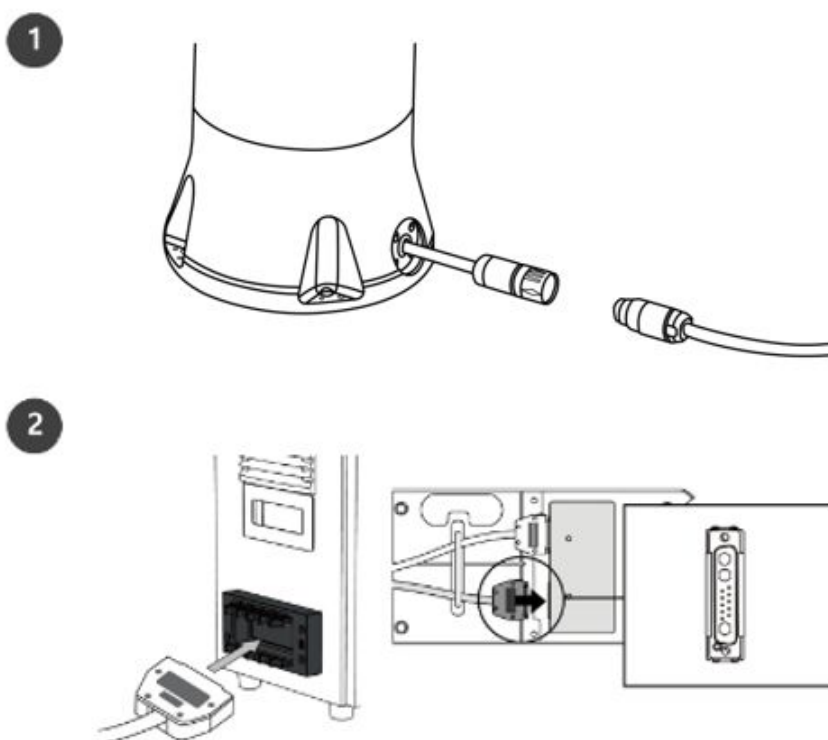

	Description
1	<p>Connect the Manipulator cable to the controller, place a securing ring</p> <ul style="list-style-type: none"> • Connect the manipulator cable to the corresponding controller connector and place a securing ring on it to prevent the cable from becoming loose.
2	<p>Connect the Manipulator cable's opposite end to the controller connector</p> <ul style="list-style-type: none"> • Push the manipulator cable's opposite end into the corresponding controller connector until a click is heard to prevent the cable from becoming loose.

⚠ Caution

- Do not disconnect the robot cable while the robot is turned on. This can cause damage to the robot.
- Do not modify or extend the manipulator cable.
- When installing the controller, secure at least 50 mm of space on each side of the controller to enable ventilation.
- Make sure that connectors are properly connected before turning on the controller.

ℹ Note

- When configuring the system, it is recommended that a noise reducer be installed to prevent noise effects and malfunction of the system.
- If the controller is influenced by noise generated by electromagnetic waves, it is necessary to install a ferrite core to ensure normal operation. The installation location is as follows:

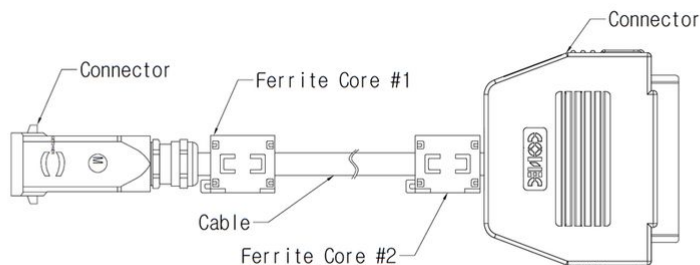

Connecting the Controller and Teach Pendant

Push the teach pendant cable into the corresponding controller connector until a click is heard to prevent the cable from becoming loose.

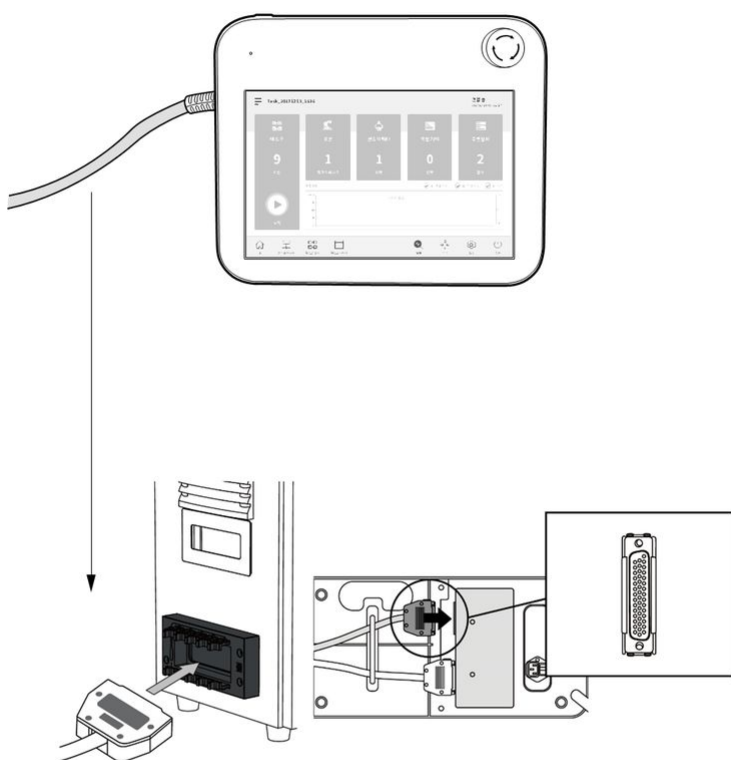

⚠ Caution

- Make sure that the pins of the cable end are not damaged or bent before connecting the cable.

- If the teach pendant is used by hanging on the AGV or on the controller, be careful not to trip on the connecting cables.
- Be careful not to allow the controller, teach pendant and cable come in contact with water.
- Do not install the controller and teach pendant in a dusty or wet environment.
- The controller and teach pendant must not be exposed to a dusty environment. Be especially careful in environments with conductive dust.

Note

- When configuring the system, it is recommended that a noise reducer be installed to prevent noise effects and malfunction of the system.
- If the teach pendant is influenced by noise generated by electromagnetic waves, it is necessary to install a ferrite core to ensure normal operation. The installation location is as follows:

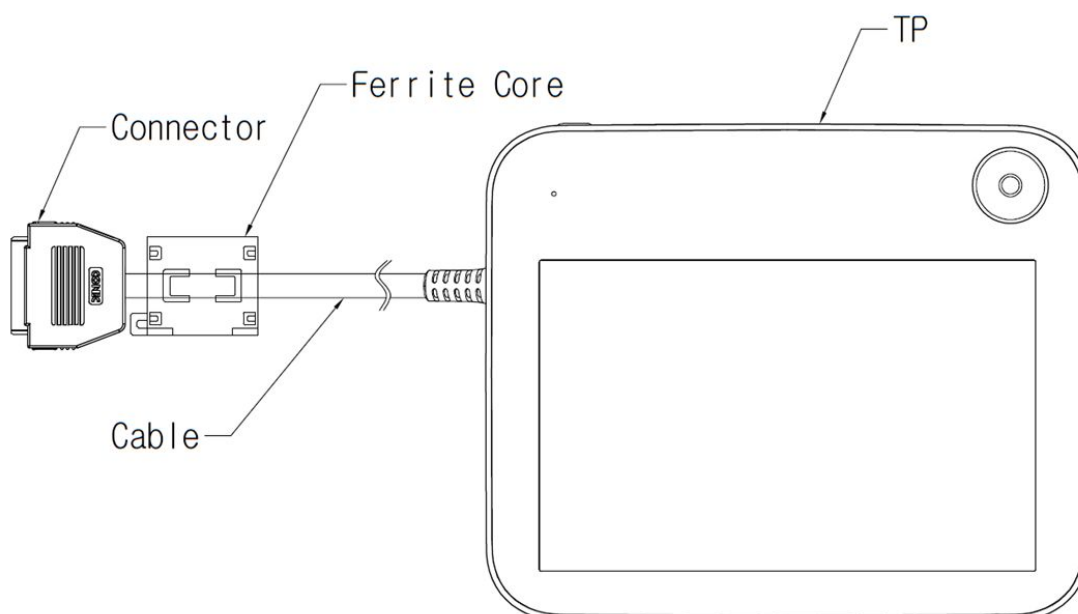

Routing of Manipulator Cable and Teach Pendant Cable

Ensure that the manipulator and teach pendant cable curvature radius is greater than the minimum curvature radius (120 mm).

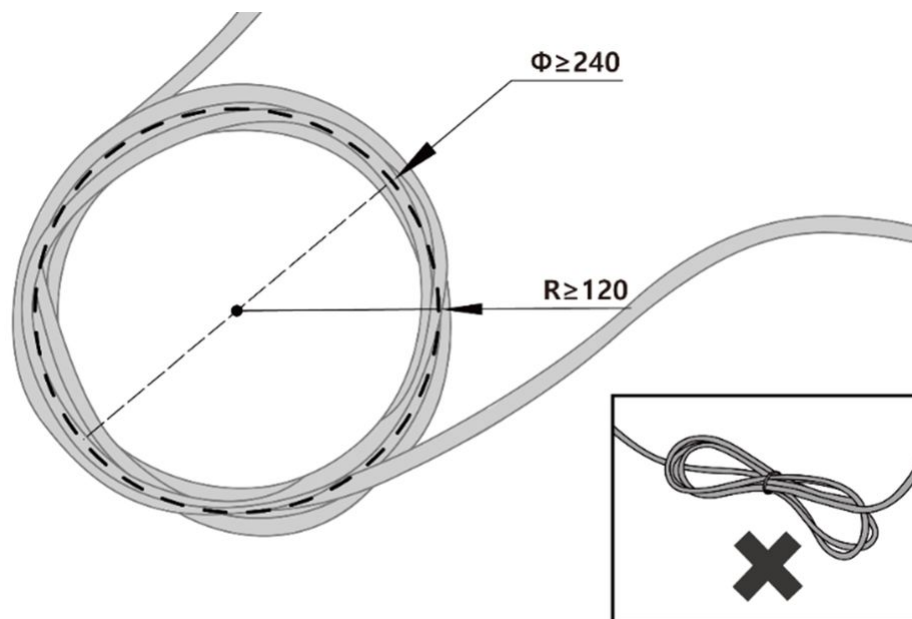

Supplying Power to the Controller

Push the power cable into the corresponding controller connector until a click is heard to prevent the cable from becoming loose.

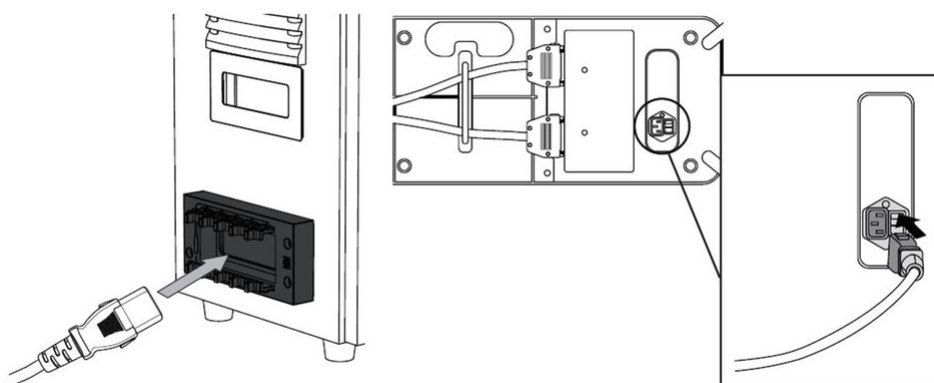

Warning

- After connecting the power cable, make sure that the robot has established a proper ground (electronic ground connection). Establish a common ground for all equipment in the system with an unused bolt related to the ground symbol inside the controller. The ground conductor must satisfy the maximum current rating of the system.
- Protect the input power of the controller using devices such as a circuit breaker.
- Do not modify or extend the robot cable. It can cause fire or controller breakdown.
- Make sure that all cables are properly connected before supplying power to the controller. Always use the original cable included in the product package.
- Be careful not to connect the polarity of the input voltage incorrectly.

Note

- When configuring the system, it is recommended to install a power switch that can turn off power to all devices in the system at once.
- If the input voltage is less than 195V, the robot's movement may be limited according to the load and motion.
- The power supply must satisfy minimum requirements such as ground and circuit breakers. The electrical specifications are as follows: (If you selected an optional controller, check the instructions in the appendix)

Parameter	Specification
Input Voltage	100 – 240 VAC
Input Power Fuse (@100-240V)	15 A
Input Frequency	47 – 63 Hz

5.3 Appendix. DC Controller

5.3.1 DC Controller (CS-02)

Product Introduction (DC Controller (CS-02))

Names and Functions

DC Controller (CS-02)

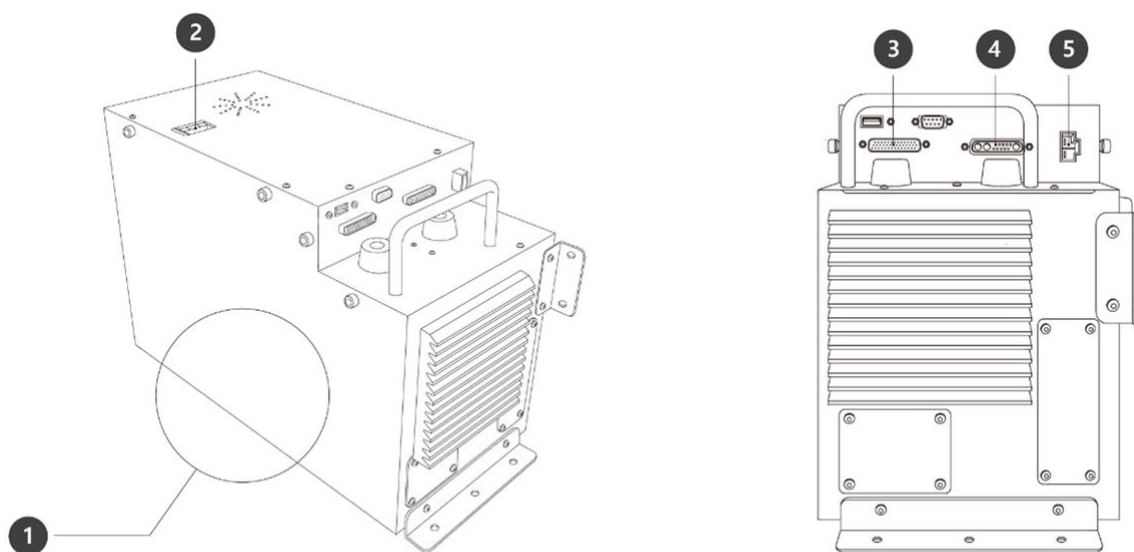

No.	Item	Description
1	I/O connection terminal (internal)	Used to connect the controller or peripherals.
2	Power switch	Used to turn ON/OFF the main power of the controller .
3	Teach pendant cable connection terminal	Used to connect the teach pendant cable to the controller .
4	robot cable connection terminal	Used to connect the robot cable to the controller .
5	Power connection terminal	Used to connect the controller power supply.

System Configuration

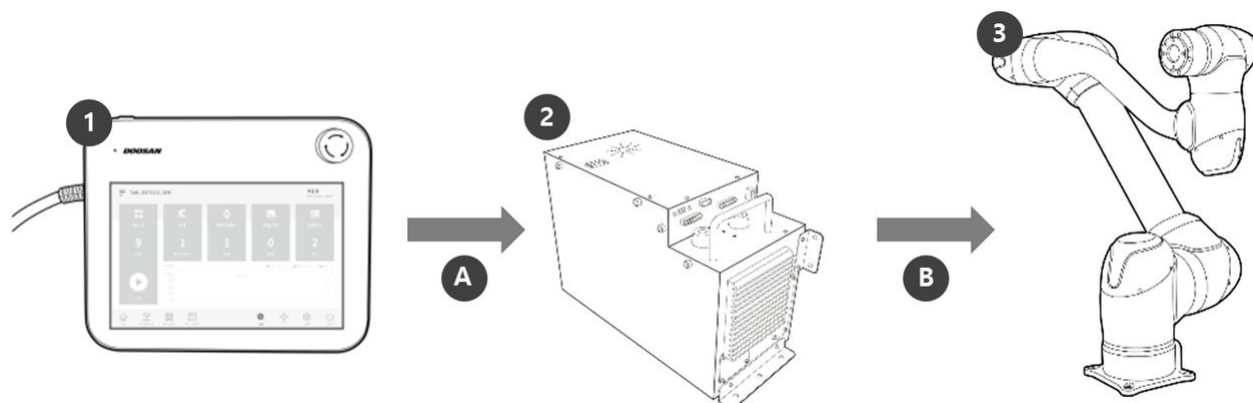

No.	Name	Description
1	Teach pendant	It is a device that manages the overall system, and it is capable of teaching the robot specific poses and setting manipulator and controller related settings.
2	Controller	It controls the robot's movement according to the pose or movement set by the teach pendant. It features various I/O ports that allow the connection and use of various equipment and devices.
3	Manipulator	It is an industrial collaborative robot that can perform transport or assembly tasks with various tools.
A	Command/ Monitoring	
B	Power Supply/ Network	

Nameplate and Label

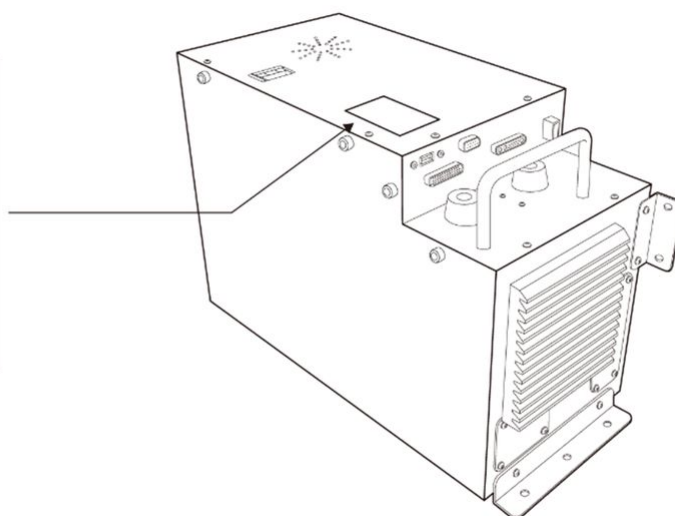
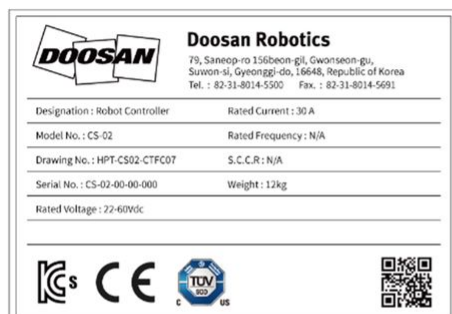

Installation (DC Controller (CS-02))

Cautions during Installation

Caution

- Secure sufficient space before installing the controller. If not enough space is secured, the controller may be damaged or the manipulator or teach pendant cable may have a shortage.
- Check the input power supply when connecting power to the product. If the connected input power supply is different from the rated power input (22-60VDC), the product may not operate properly or the controller may be damaged.

Installation Environment

When installing the controller, consider the following.

- Secure sufficient space before installing the controller.
- The controller must be fixed.
- Make sure no component is not fixed in the mobile vehicle.

Hardware Installation

Install the robot, controller and teach pendant, the key components of the system, and supply power to them before operating the manipulator. Installation of each component is as follows:

Securing the Controller

After placing the controller, use M5 bolts in six 6 mm holes in the fixation plate to secure the controller.. (if the control is placed horizontally, use five M5 bolts)

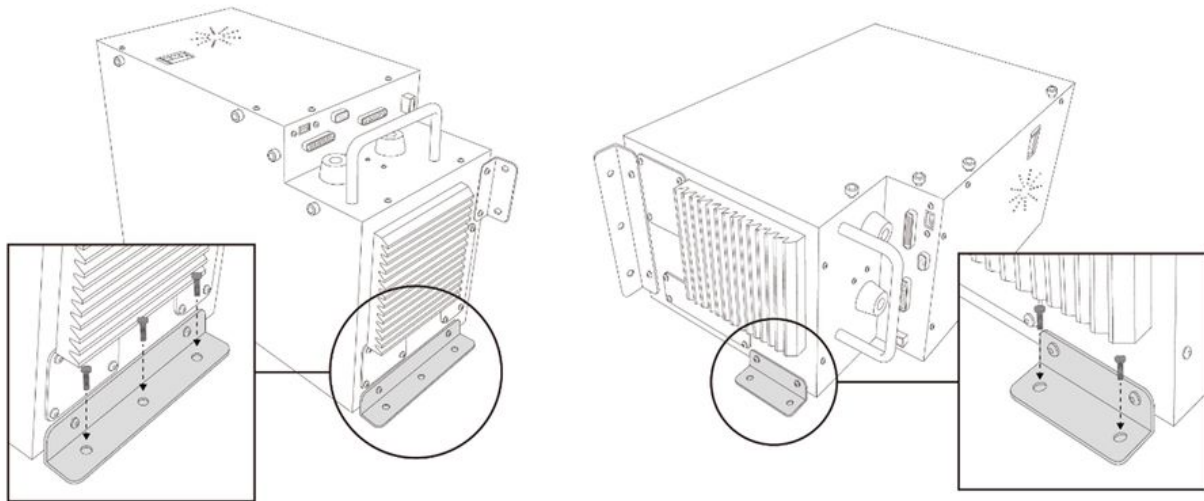

⚠ Caution

Tighten the bolts all the way to prevent loosening.

Connecting the Manipulator and Controller

1

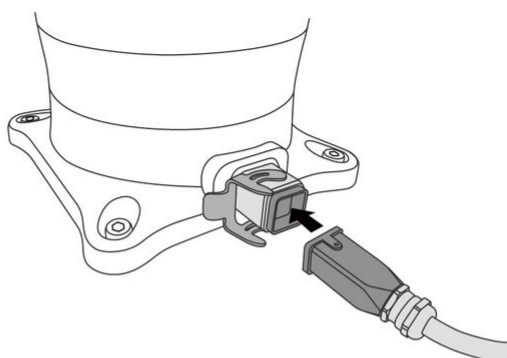

2

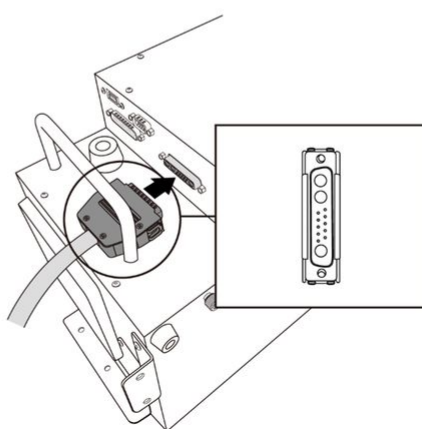

	설명
1	<p>Connect the manipulator cable to the controller, place a securing ring</p> <ul style="list-style-type: none"> Connect the manipulator cable to the corresponding controller connector and place a securing ring on it to prevent the cable from becoming loose.
2	<p>Connect the manipulator cable's opposite end to the controller connector</p> <ul style="list-style-type: none"> Push the manipulator cable's opposite end into the corresponding controller connector until a click is heard to prevent the cable from becoming loose.

⚠ Caution

- Do not disconnect the robot cable while the robot is turned on. This can cause damage to the robot.
- Do not modify or extend the robot cable.
- When installing the controller in the mobile vehicle, secure at least 50 mm of space on each side of the controller to enable ventilation.
- Make sure that connectors are properly connected before turning on the controller.

Note

- When configuring the system, it is recommended that a noise reducer be installed to prevent noise effects and malfunction of the system.
- If the controller is influenced by noise generated by electromagnetic waves, it is necessary to install a ferrite core to ensure normal operation. The installation location is as follows:

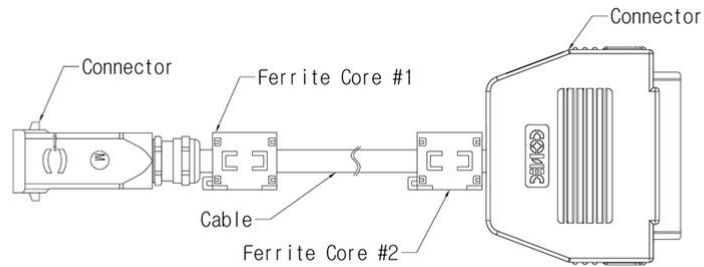
**Connecting the Controller and Teach Pendant**

Push the teach pendant cable into the corresponding controller connector until a click is heard to prevent the cable from becoming loose.

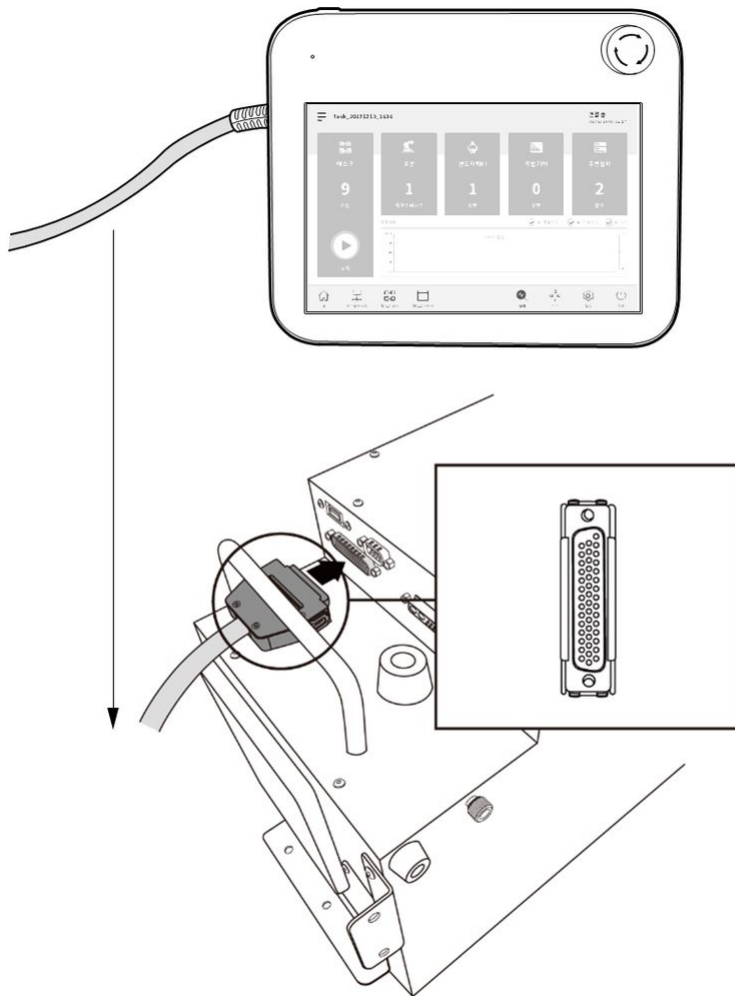
**⚠ Caution**

- Make sure that the pins of the cable end are not damaged or bent before connecting the cable.
- If the teach pendant is used by hanging on the mobile vehicle or on the controller, be careful not to trip on the connecting cables.
- Be careful not to allow the controller, teach pendant and cable come in contact with water.
- Do not install the controller and teach pendant in a dusty or wet environment.
- The controller and teach pendant must not be exposed to a dusty environment. Be especially careful in environments with conductive dust.

i Note

- When configuring the system, it is recommended that a noise reducer be installed to prevent noise effects and malfunction of the system.

- If the teach pendant is influenced by noise generated by electromagnetic waves, it is necessary to install a ferrite core to ensure normal operation. The installation location is as follows:

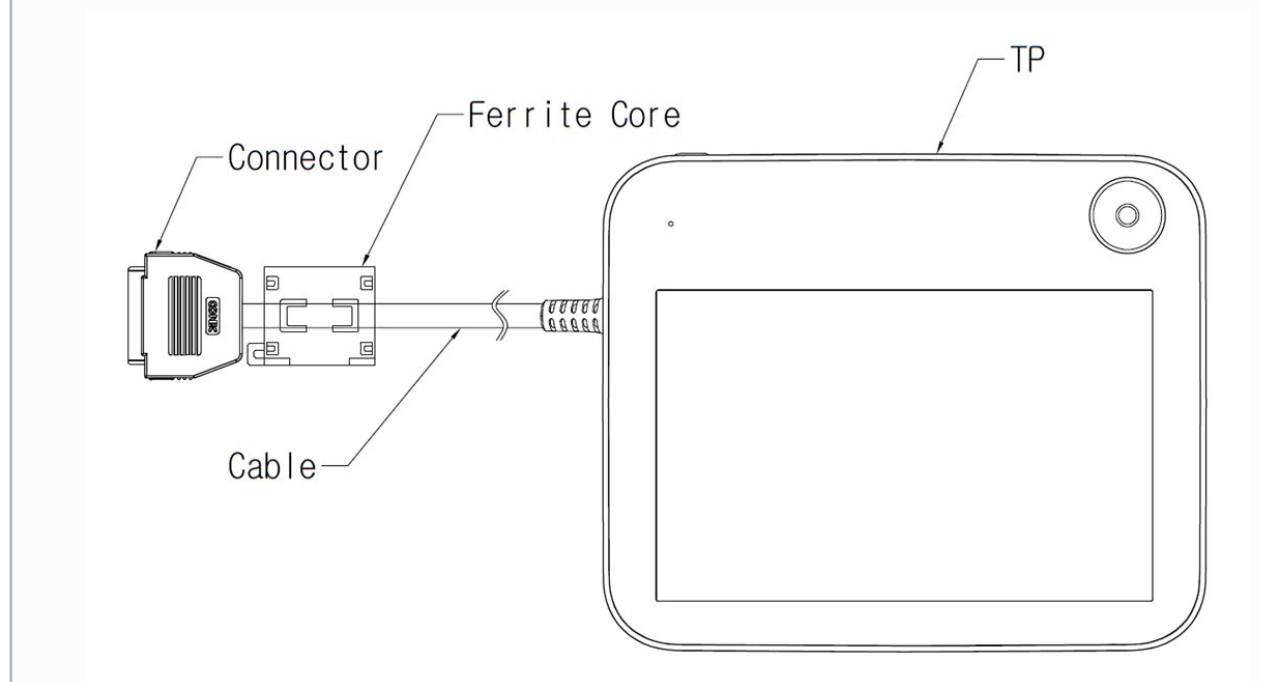

Routing of Manipulator Cable and Teach Pendant Cable

Ensure that the manipulator and teach pendant cable curvature radius is greater than the minimum curvature radius (120 mm).

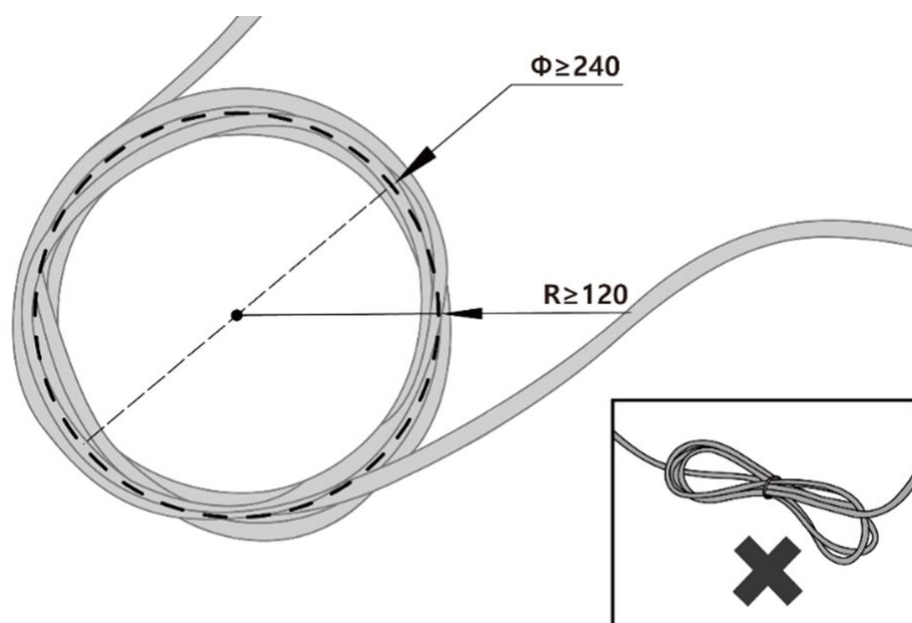

⚠ Caution

- Ensure that the curvature radius between the teach pendant cable and teach pendant connector is greater than the minimum curvature radius (120 mm).
- If the curvature radius is smaller than the minimum curvature radius (120 mm), cable disconnection or product damage may occur.
- In environments where electromagnetic noise can occur, proper cable installation must be taken to prevent malfunctions.

Supplying Power to the Controller

Push the power cable into the corresponding controller connector until a click is heard to prevent the cable from becoming loose.

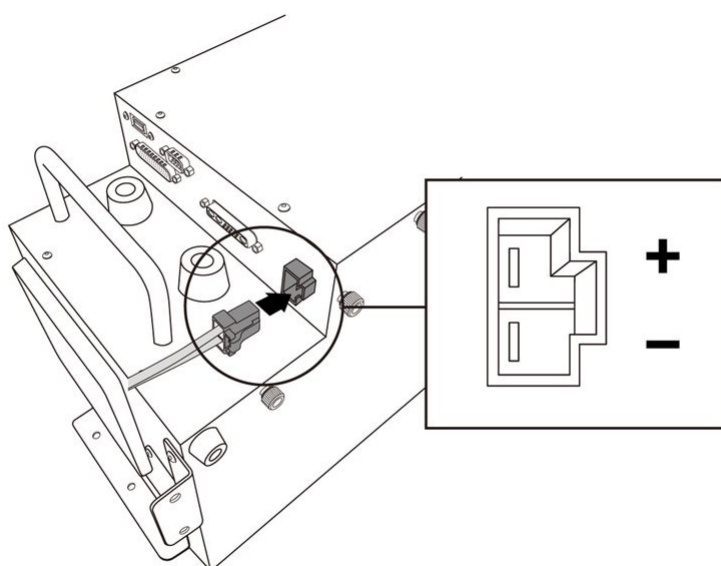

Warning

- After connecting the power cable, make sure that the robot has established a proper ground (electronic ground connection). Establish a common ground for all equipment in the system with an unused bolt related to the ground symbol inside the controller. The ground conductor must satisfy the maximum current rating of the system.
- Protect the input power of the controller using devices such as a circuit breaker.
- Do not modify or extend the robot cable. It can cause fire or controller breakdown.
- Make sure that all cables are properly connected before supplying power to the controller. Always use the original cable included in the product package.
- Be careful not to connect the polarity of the input voltage incorrectly.

Note

- When configuring the system, it is recommended to install a power switch that can turn off power to all devices in the system at once.

- If a controller for the AGV is used, the robot's movement may be limited according to the load and motion.
- If the input voltage is less than 48V, the robot's movement may be limited according to the load and motion.
- The power supply must satisfy minimum requirements such as ground and circuit breakers. The electrical specifications are as follows:

Parameter	Specification
Input Voltage	22 – 60 VDC
Rated Input Current	30 A

Interface (CS-02)

Connecting Controller I/O

External devices can be connected to the controller through the controller I/O terminal after removing the I/O connection plate.

Network Connection

External Internet network, TCP/IP equipment, Modbus equipment and SVM can be connected to the network router in the controller after removing the network connection plate.

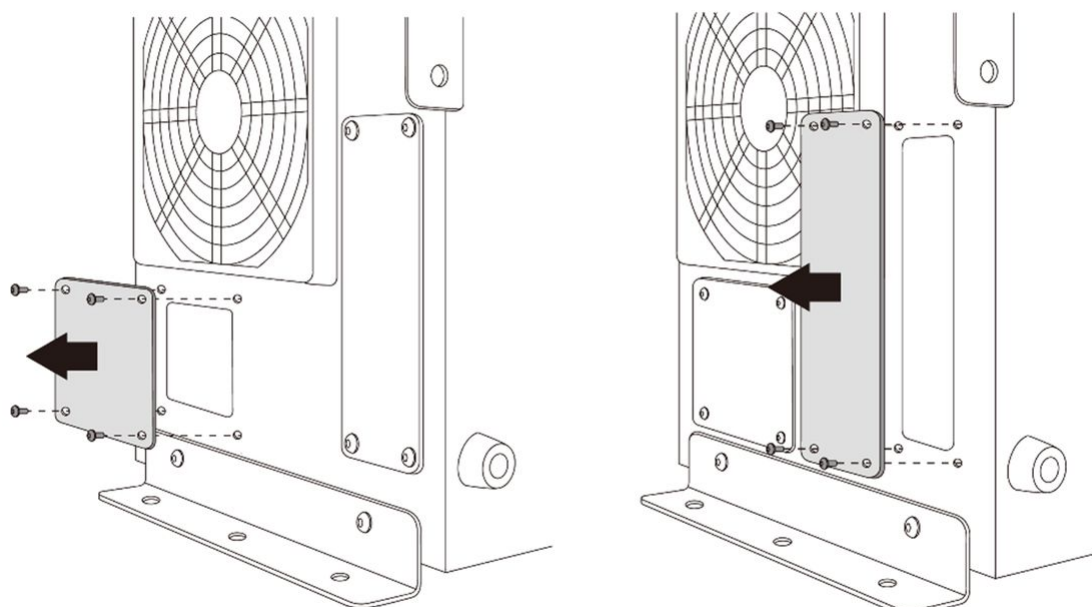

5.4 Appendix. H-Series Handling Guide

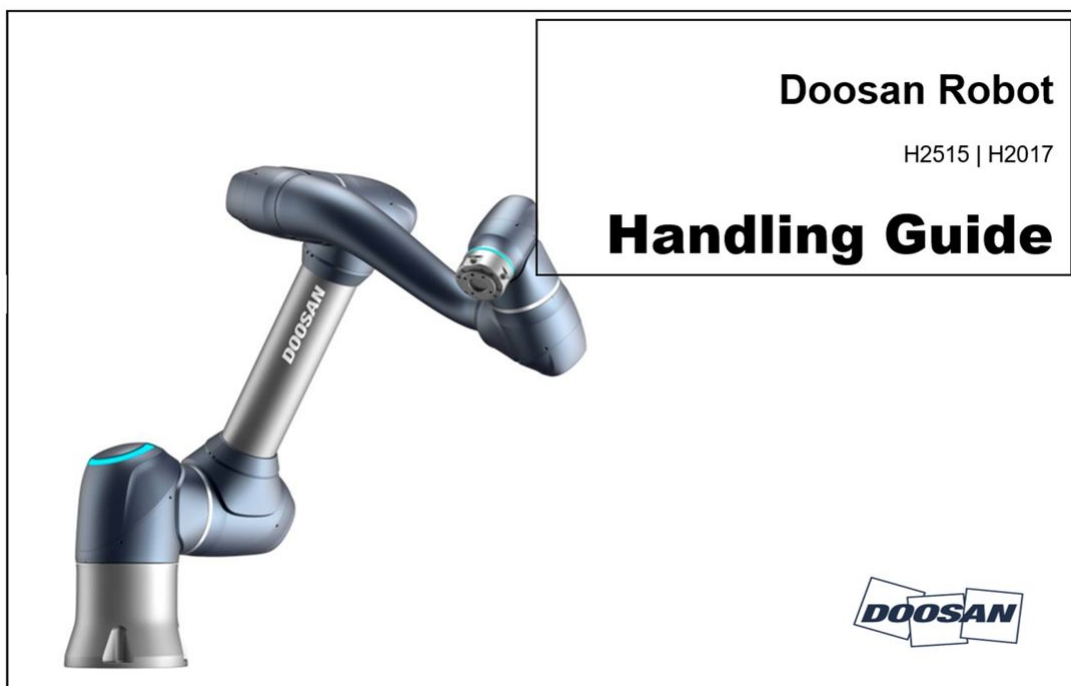

Caution

- Doosan Robotics does not assume responsibility for any damages that occurs during the use of lifting equipment.
- If the robot is transported by packaging it with packaging materials, store the robot in a dry location. If the robot is stored in a location with high humidity, condensation may occur, resulting in robot
- When relocating the robot, carefully consider the weight and have a suitable number of people hold the link and base of the robot.
- When relocating the controller, hold the handle on the side of the box.
- When transporting the robot or controller, make sure to maintain the proper posture. Failure to do so may result in back injury or other physical injuries.
- When transporting the robot using lifting equipment, make sure to observe all related national and regional regulations.
- Doosan Robotics does not assume responsibility for any damages or losses that occur during transportation, so make sure to transport the robot safely according to the user manual.

5.4.1 Quick Guide

Thank you for choosing this Doosan Robotics product.

This guide provides the minimum amount of information required for three handling methods for relocation and installation of the H-Series robot safely. Make sure to follow the instructions in this guide when handling the robot.

- If the robot needs to be relocated, be sure to use the packaging materials provided with the initial delivery. For this purpose, store the packaging materials and fillings in a dry, cool location.
- Industrial robot's must be installed with careful consideration given to the inspection standards defined by the Regulations and Safety Inspection of the Occupational Safety and Health Standard Announcement (if the robot is subject to inspection).
- The robot can be transported using a crane, lift or hand lift, and when using a crane to lift the robot, be sure to comply with regulations of the area or country of jurisdiction.
- Utilize the packing posture for robot installation and relocation.
- Make sure whether all standard and additional (optional) components are included, and contact the sales agent if there are any problems.
- The packaging materials and bolts are designed specifically for the relocation of the robot. Do not use them for any purposes other than relocating the robot.
- When relocating the robot, do not apply force to the exterior of the robot. Failure to comply with these instructions may result in injuries.
- Remove the packaging materials and bolts after installation. Make sure to store the packaging materials and bolts in case the robot needs to be relocated.
- Before relocation, make sure that the bolts and packaging materials are secure.

1. 1. When a crane (hoist) is used

- Use a spin-resistant cable capable of handling the weight of the robot.
- The wire rope must be at least 1500mm long.

Items	Minimum Capacity
Crane	1,000 kg
Wire Rope (EA)	1,000 kg

1.1 When securing a rope to a robot frame,

- attach the rubber jig provided between axes 3 and 4 before the operation. (Refer to Figure below) (See figure below)

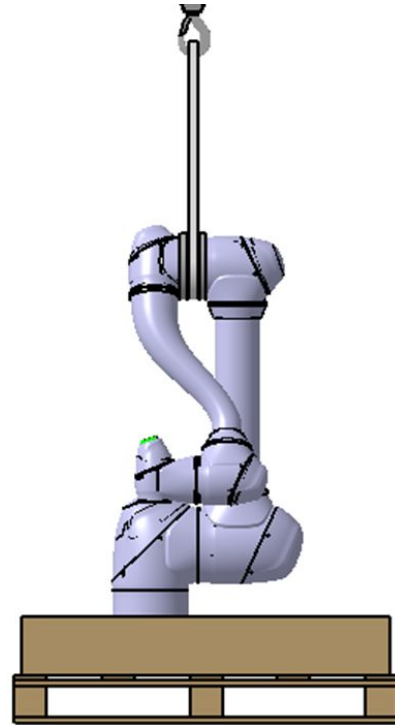
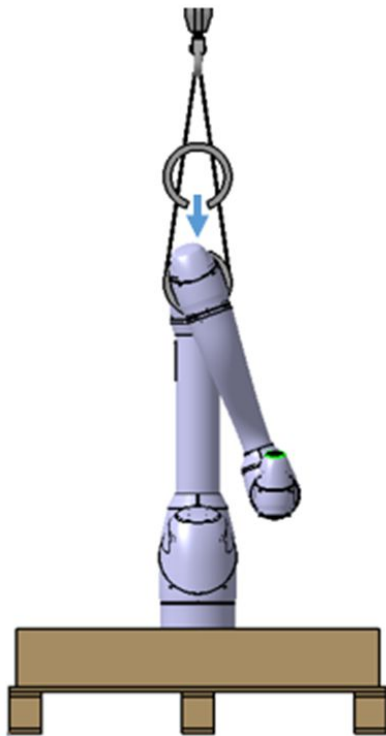

1.2 If the rope is secured on the bottom packaging material

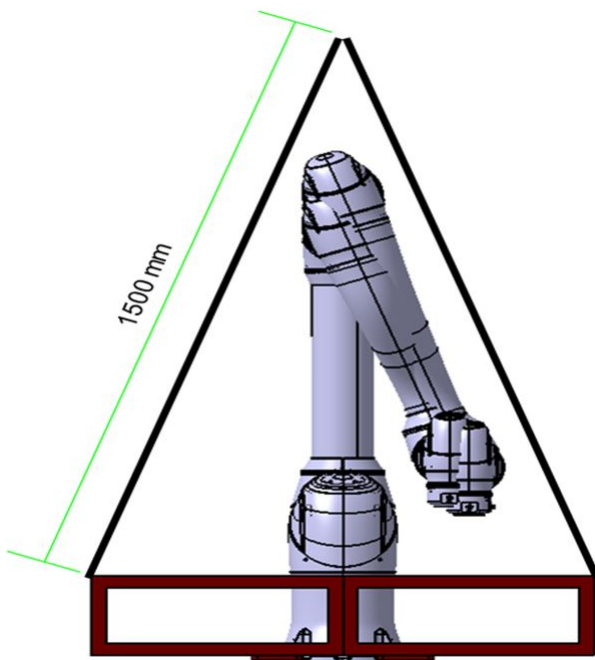

Warning

- When the robot is lifted, it may tilt depending on its pose and optional attachments

- Do not walk under the robot body when lifting.

2. When Using Forklifts

- If the robot needs to be relocated in its packaged state, lift it from the bottom of the package using a forklift.
- During installation, relocate the robot using the lower packaging materials while taking caution to avoid damage to the robot.

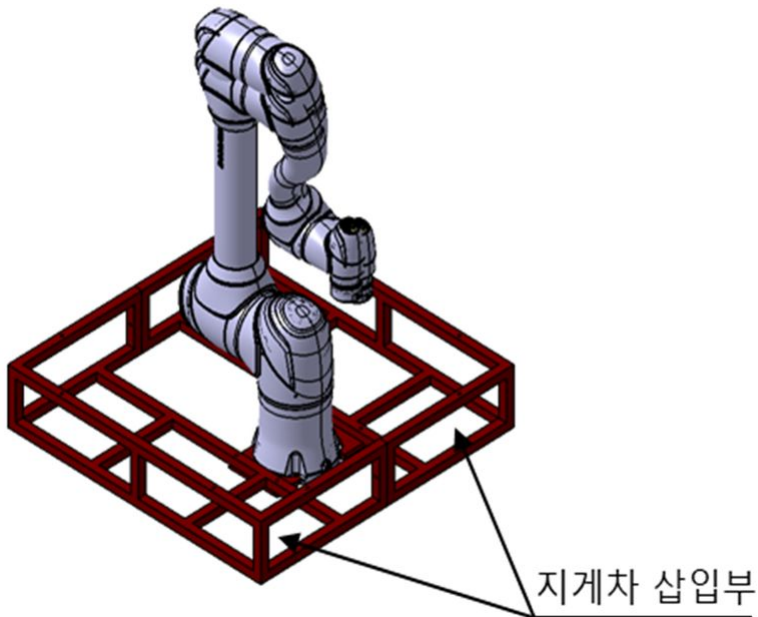

3. When Lifting Equipment is Unavailable

- If you need to relocate the robot due to the unavailability of lifting equipment, relocate the robot complying with the regional and national transport work standards.
- It is recommended to use the lower packaging materials as handles as below.

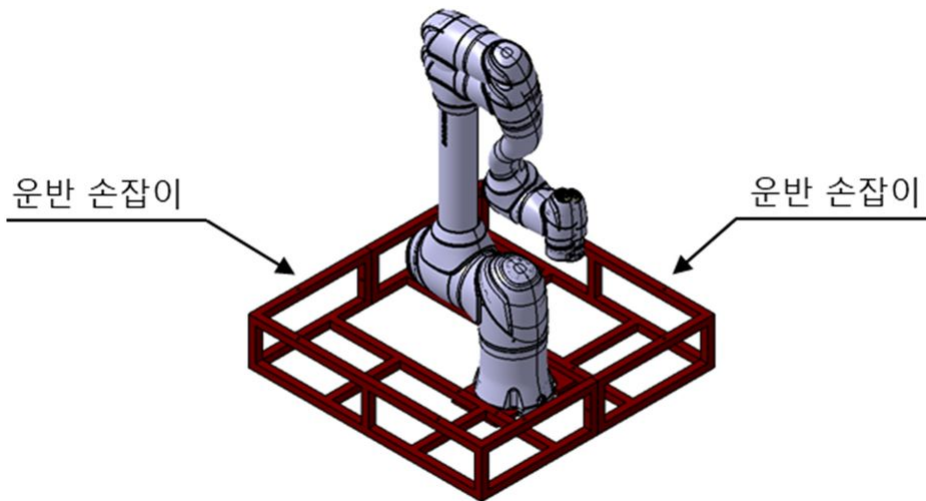

Note

In the case of In the case of H series, 4 M8 Taps are applied to the base to facilitate handling so that the work can be easily done, so please use them when working.

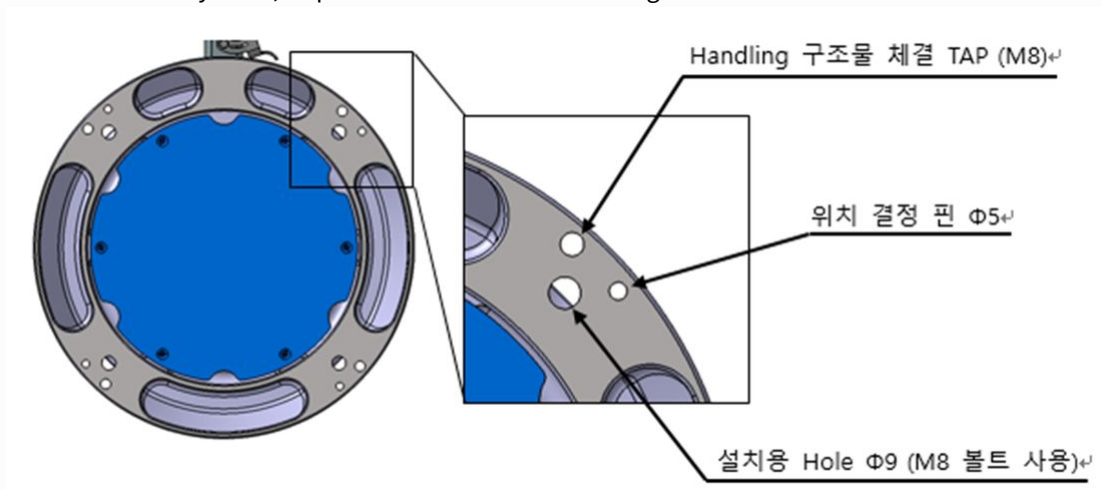

5.5 Appendix. Doosan Robot Allowable Torque

5.5.1 Doosan Robot Allowable Torque

Caution

- The values below are the maximum allowable torque values for each joint and should not be used in excess of that value.
- It is recommended to operate within a range smaller than the values below when operating a robot.
- When a collision exceeding the allowable torque is detected while using the E-Series, slight misalignment may occur. If misalignment occurs, please perform Mastering based on the Home imprint for each axis.

Allowable Max. Torque[Nm]

M-Series

Axis	1	2	3	4	5	6
M0609	160	160	90			
M0617				45	45	45
M1013	340	340	160			
M1509						

H-Series

Axis	1	2	3	4	5	6
H2017	430	430	340	160	90	45
H2515						

5.6 Appendix. Troubleshooting Guide

5.6.1 Application Recovery Mode Screen

If a software error is detected during robot booting, the system enters Application Recovery Mode. This screen offers functions to preserve and restore application data. This screen is only available in English.

Using Application Recovery Mode Functions

Application Recovery Mode

An error occurred while running Application. If the symptoms are repeated after restarting, restore the system using the provided recovery function.

2 View Error Log

1

Robot Serial No.
XXXXXX-MXXXX

i [Preserve] The functions below are for data retention. Make sure to Download backup data and system logs with USB.

3

System Log Export

4

Backup Database

i [Troubleshoot] The functions below will return to the initialized robot. To use the function, you must enter the safety password.

5

Clean Database

6

Restore Database

7

Delete 3rd-Party Workcell

8

System Restore

9

Integration Update

10

Controller Restart

No.	Item	Description
1	Robot Serial Number	This displays the serial number of the connected robot.
2	View Error Log	This displays the log of errors that triggered recovery mode.
3	Export System Log	This executes a function to extract the system log. The log from 2 days prior to the present day is extracted.
4	Database Backup	This executes a function to back up the database of the connected robot. Data backed up using this function can only be restored with the Restore Database function on this screen.
5	Reset Database	This executes a function to reset the database of the connected robot to its default state.
6	Restore Database	This restores the database using the file created with the Database Backup function on this screen.
7	Delete 3rd Party Workcell Item	This deletes 3rd party Workcell Items installed via (2.12.2-en_US) Workcell & Skill Installation and Removal(p. 374) .
8	Restore System	This restores the application to a specific version. It works the same as (2.12.2-en_US) System Restore(p. 367) function.
9	Unified Update	If the update fails, the system can be re-installed using the (2.12.2-en_US) Unified Update(p. 366) function.
10	Restart	This restarts the controller.

5.6.2 Series Compatibility Error Screen

The controller stores the execution information of the connected robot. This information varies depending on the robot series, so if a robot of a different series is connected, the series compatibility error screen will be displayed. This screen provides the options of saving the current execution information or resetting the data. This screen is only available in English.

Series Compatibility Error Screen Functions

Controller & Robot Compatibility Error

The software installed on the controller and the software of the currently connected robot series do not match, so it cannot boot normally.

Compatibility Test Result

1 Controller S/W
A Series

2 Robot
M Series

i Reconnect with the same robot series as the software series installed on the controller.
i Alternatively, if you want to use the currently connected robot series, press the 'Clean Database' button below to delete the data installed on the controller and use it.

i 'Clean Database' will erase all Workcell Manager Data entered by the user. For safe operation, you should be backup database first using USB and then clean database.

3
Backup Database

4
Clean Database

Controller Power Off

No.	Item	Description
1	Controller S/W	This displays the robot series information for the execution data saved in the controller.
2	Robot	This displays information on the newly connected robot series.
3	Database Backup	This executes a function to back up the database of the connected controller. The backup file can be used to restore data through “(2.12.2-en_US) Backup & Restore(p. 371)”
4	Reset Database	This executes a function to reset the database of the connected controller. To connect a robot of a series different from the current controller information, a reset must be executed.

Robot Series Swap

To use a robot from a different series, data back up and initialization must be executed according to the on-screen instructions. Controller software versions higher than V2.7 support all robot series (M, H, and A series). However, a single controller cannot be used with an M, H and A series robot combination.

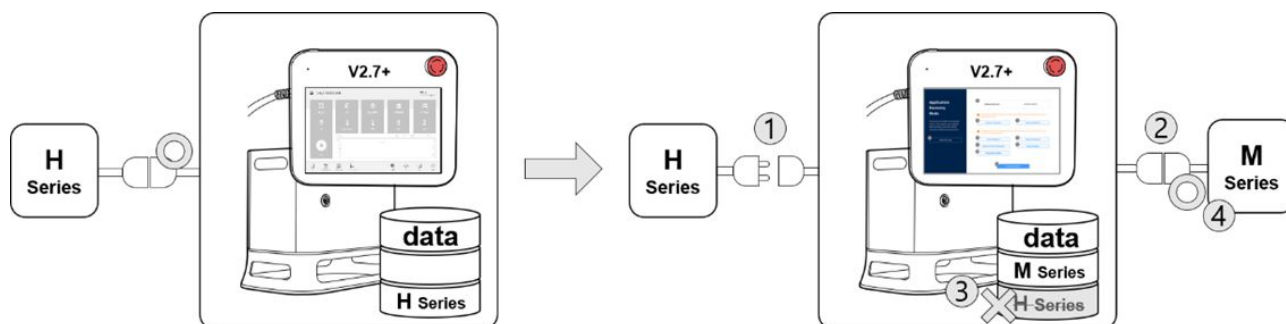

For example, if a controller with a software version higher than V2.7 is being used with an H series robot, disconnecting the existing robot and connecting an M series robot will cause a compatibility error screen to be displayed. Follow the on-screen instructions to execute data backup and initialization of H series, then turn the controller power off and on to allow an M series robot to be connected. Compatibility of each software version is as follows:

Series Compatibility of each Software Version

Software Version	Description	Series Swap Support
M2.x.x.x	M Series-only Software	Not compatible.
A2.5.x	A Series-only Software	Not compatible.
V2.6.2	H Series-only Software	Not compatible
V2.6.3	Integrated Software (H/M Series) (Cannot be installed on A Series)	Can be swapped between H and M series
V2.7+	Integrated Software (A/H/M Series)	Can be swapped between H and M series

Note

- A/M/H series have different connector structures for robot and controller connection, so the robot series cannot be swapped with each other.
- The compatibility error screen is not displayed if a different robot of the same series is connected.

Caution

- Take caution after swapping to a different model of the same series, as Safety Parameters, TCP, Tool Weight and various user defined settings are maintained.
- Robot series compatibility may vary depending on the software version.
- For a detailed change history of each software version, refer to the Release Note at RobotLAB (<https://robotlab.doosanrobotics.com>).

5.6.3 Releasing Stop due to Space Limit and Zone Violations

When Servo On is attempted after the robot stopped due to space limit and zone violations, Servo On is set with the following alarm messages displayed.

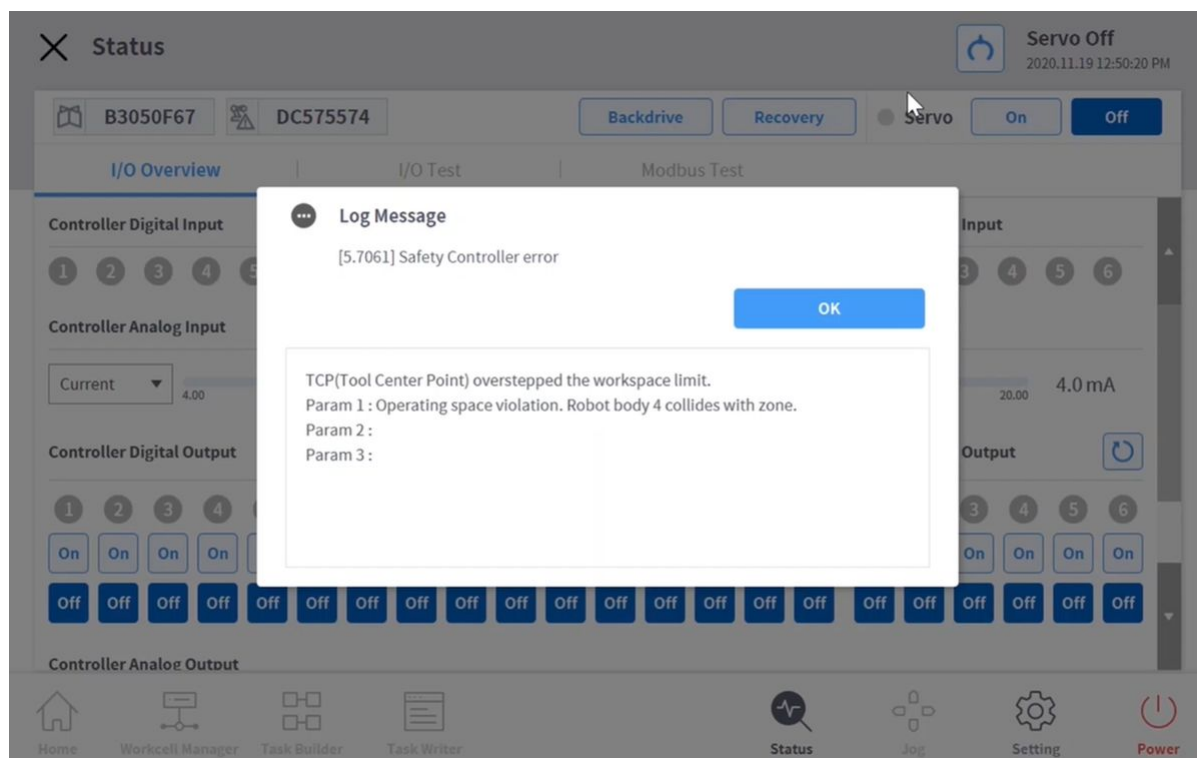

If the robot stopped due to space limit and zone violations, use the **Status > Safety Recovery > Software Recovery** function to move the robot to a safe area. The following sample showcases how to move the robot to a safe area using the software recovery function.

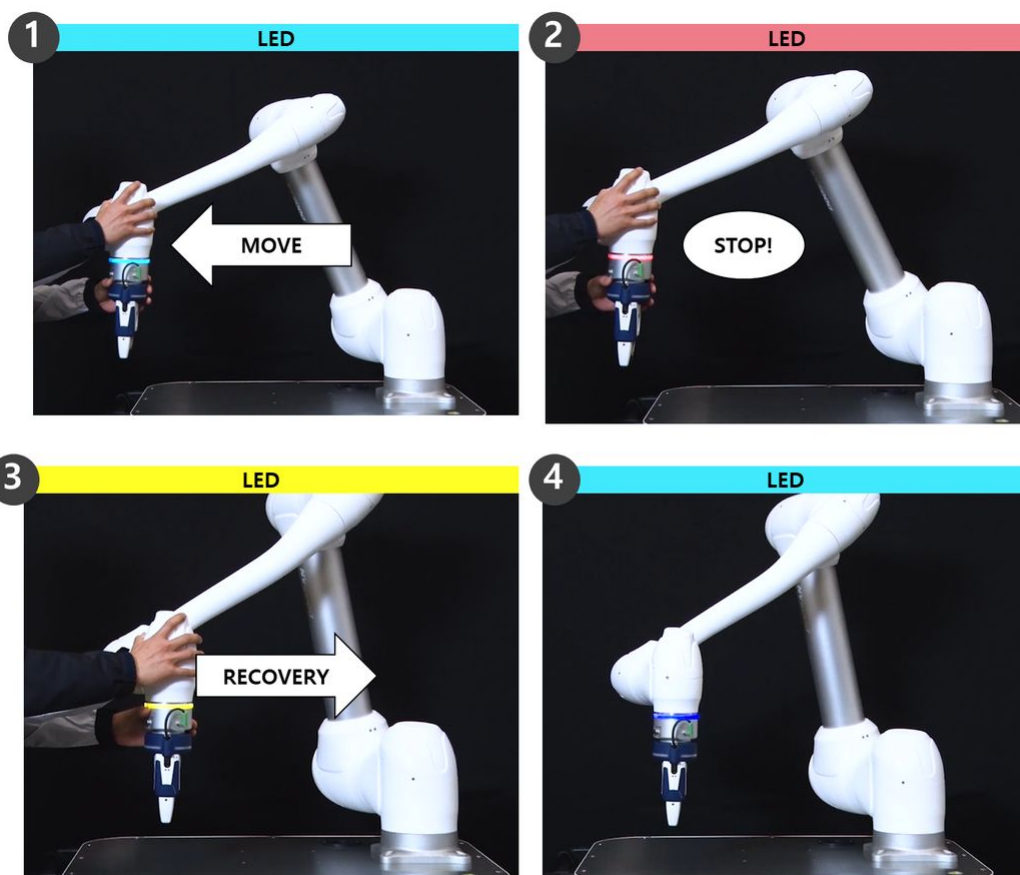

1. The robot moves freely in the work zone during work.
 - Robot Status: Servo On
 - LED: Cyan
2. The robot stops when it exits the work zone.
 - Robot Status: Servo Off
 - LED: Red
3. Set Servo On through **Status > Safety Recovery > Software Safety Recovery**, and move the robot to a safe area.
 - Robot Status: Servo On (Recovery Mode)
 - LED: Yellow
4. Exit the safety recovery screen and press **Status > Servo On**, and the robot will resume normal operation.
 - Robot Status: Servo On
 - LED: Cyan

For more information about software safety recovery, refer to [\(2.12.2-en_US\) Using Software Recovery Mode\(p. 305\)](#).

5.7 Appendix. Welding Work Overview

5.7.1 EtherNet/IP Interface Welding Machine Connection Example

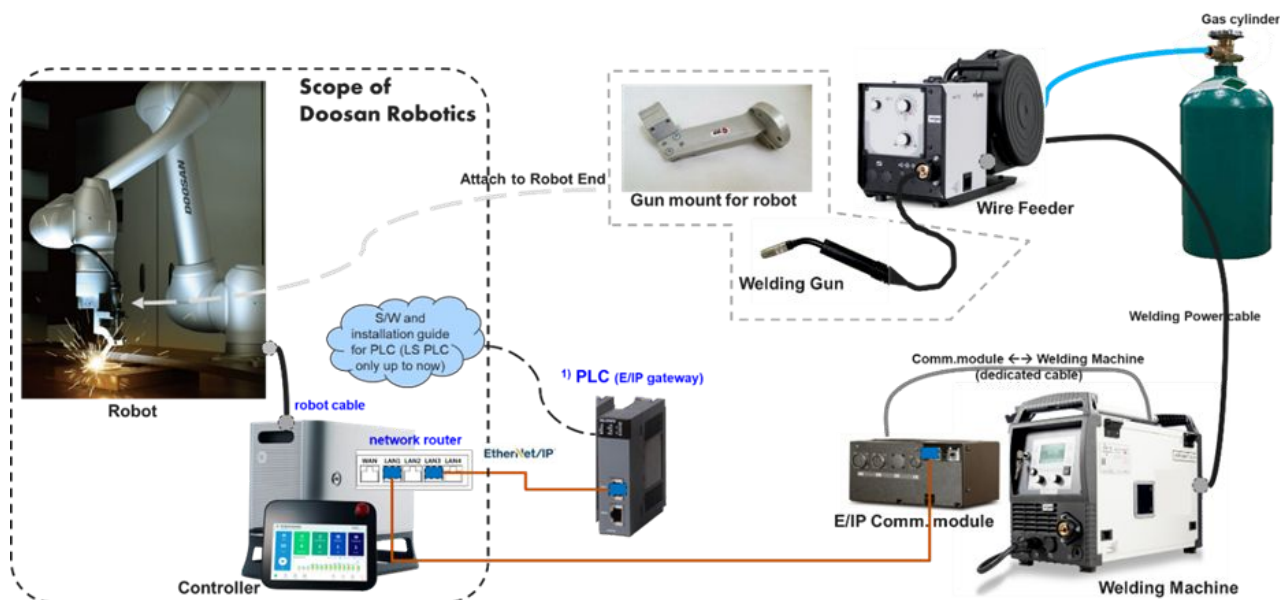

5.7.2 Flow of Welding Work Utilizing Doosan Robots

The starting process of the robot-welder connection for welding automation will lead to repeated welding work performed by welding personnel in the following general order. In this flow, the initial connection and set-up is sometimes performed by a professional system integrator (SI), and welding condition set-up requires specialized knowledge regarding welding. In particular, electrical insulation and organized surroundings are essential conditions to be confirmed prior to welding work. The right side of the flow chart below shows the functional menus offered by Doosan Robotics' welding function. Please use the simplified image for easy reference regarding welding features. Please refer to the welding technical note provided by the Doosan Robotics Robot LAB for detailed explanations regarding each menu.

Note

- Please refer to the welding technical note provided by the Doosan Robotics Robot LAB for detailed explanations regarding each menu.
- [Robot LAB] <https://robotlab.doosanrobotics.com>

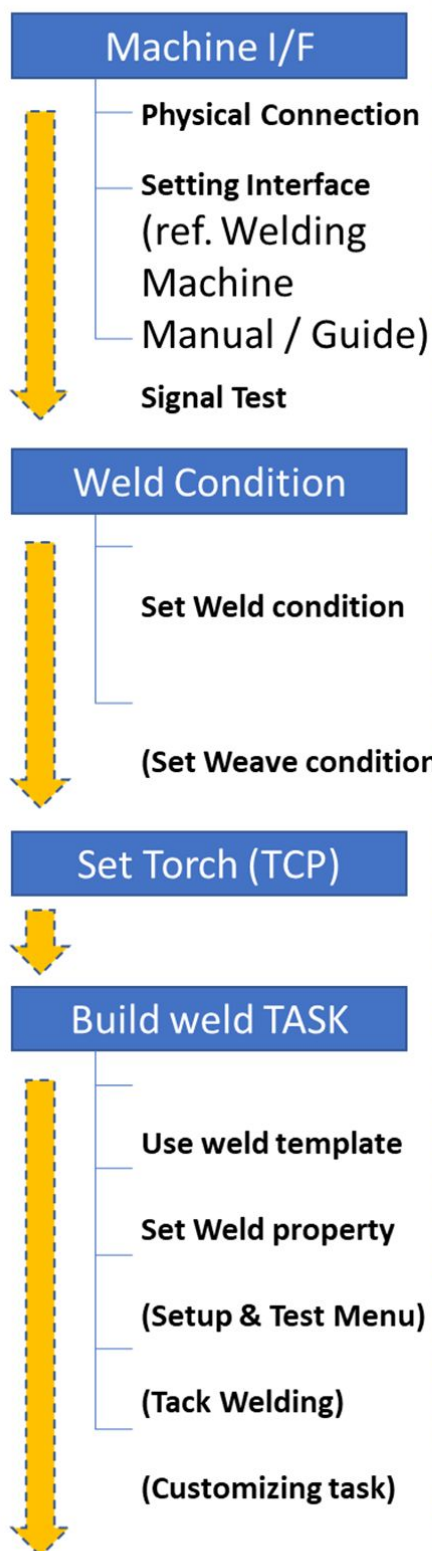
[Overall Process]**(Doosan Robot)****Analog I/F**

D-I/O, A-I/O (isolation)

WCM > Peripheral > Analog
Welding Mchn.

(Set D-I/O, A-I/O Channel)

Digital I/F

RJ45 conn. + PLC(E/IP gateway)

WCM > Peripheral >
Digital Welding Mchn.→ Interface Setting
(Set Comm. Signals)

→ Signal Test

** Only one welding machine can be activated.

WCM > Peripheral > Welding Condition > Cond.List
(Add / Duplicate / View(Adjust) / Save as Conditions)
> View Condition
(Edit & Save / Save as)WCM > Peripheral > Weaving Condition > Cond.List
(Add / Duplicate / View(Adjust) / Save as Conditions)
> View Condition
(Edit & Save / Save as)WCM > Peripheral > Welding Torch
(Input known values / Use TCP Calculation)TB/TW > Command > Welding Command
(Select and Input Welding Template into MainSub)TB/TW>Task List>StartWelding > Property
(Select Welding/Weaving condition and Torch Tool)(1. For motion test only, select Simulation mode)
(2. output Signal Check before actual welding)TB/TW>Task List>StartWelding>Property>TackWelding
(select Tack Welding Cond. and Use cockpit to weld)TB/TW>Task List>Move#(in the welding loop)>Property
(Adjust welding property for each motion if needed.
(Arc-On/Off, Weld Cond., Offset and Weaving Width, Welding
Speeds are changeable)*continued >>*

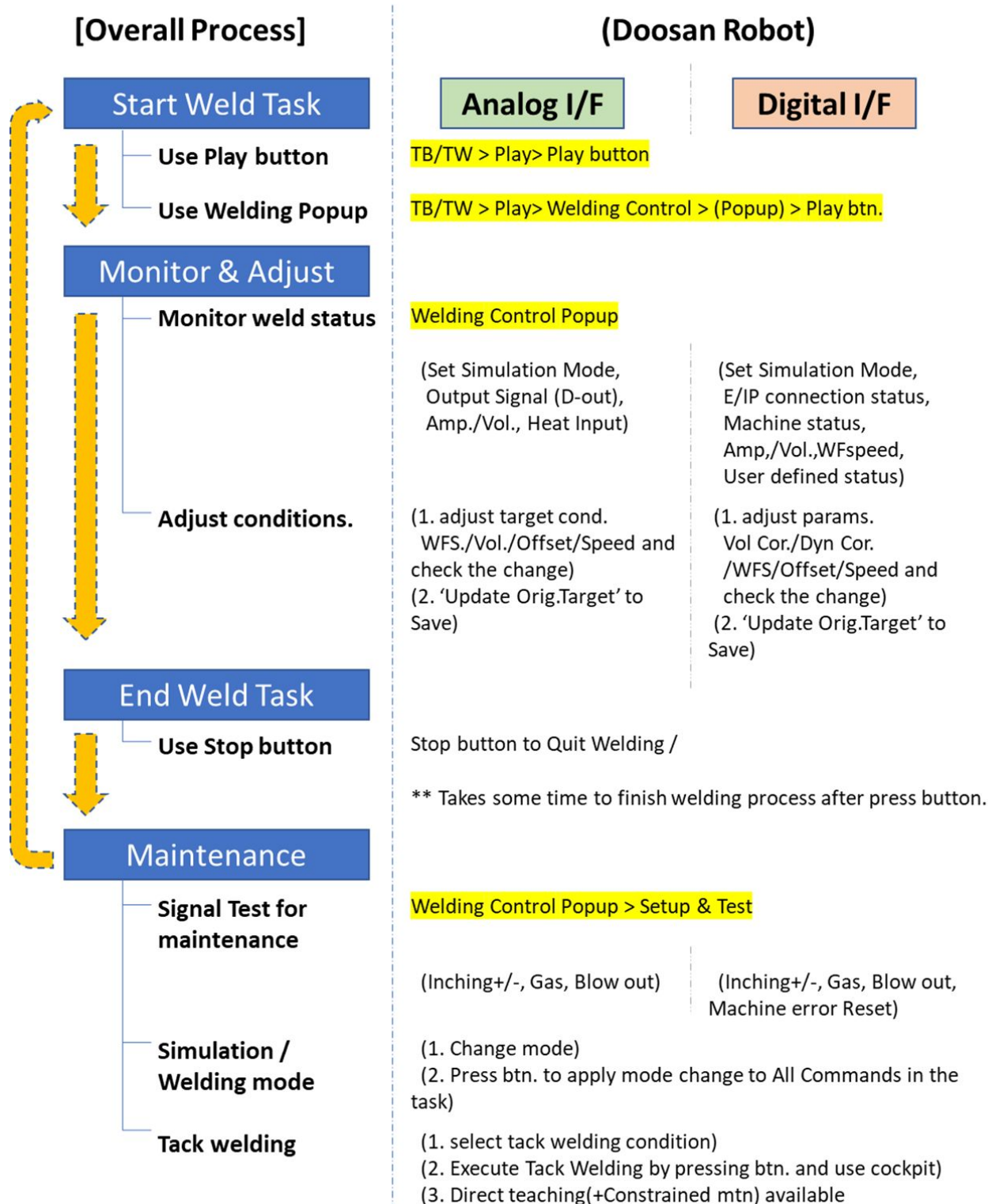

5.8 Appendix. DART Platform Installation Requirement (minimum, recommended)

5.8.1 Minimum/Recommended Requirement

The minimum installation requirements for the DART Platform are as follows:

- OS: Windows 7 Enterprise Service pack1 (64 bit) or higher
- CPU: 2.20 GHz or higher
- GPU: GMA 4500 and GMA HD (Intel) or equivalent specification
- Memory: 4 GB
- Java SDK: jdk1.8.0_152 (64 bit)
- Screen resolution: 1280 x 800

The recommended installation requirements for the DART Platform are as follows:

- OS: Windows 10 Enterprise (64 bit)
- CPU: 2.80 GHz or higher
- GPU: GMA 4500 higher and GMA HD (Intel) higher
- Memory: 16 GB
- Java SDK: jdk1.8.0_152 (64 bit)
- Screen resolution: 1280 x 800

5.8.2 DART Platform Resolution support

DART Platform can perform resolution-specific scaling to accommodate a variety of resolutions. (**Resolution changes are only performed when the program is running and do not occur in real time.**)

The supported resolutions are as follows:

- 800 x 600
- 1024 x 768
- 1152 x 864
- 1176 x 664
- 1280 x 720
- 1280 x 768
- 1280 x 800
- 1280 x 960
- 1280 x 1024
- 1360 x 768
- 1366 x 768
- 1440 x 900
- 1600 x 900
- 1680 x 1050
- 1768 x 992

- 1920 x 1080

Example of displaying the DART Platform at 800 x 600 resolution

